

Service Manual

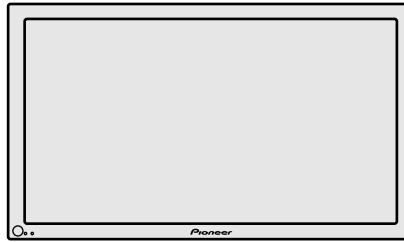

PDP-504CMX

ORDER NO.
ARP3241

PLASMA DISPLAY

PDP-504CMX PDP-434CMX

THIS MANUAL IS APPLICABLE TO THE FOLLOWING MODEL(S) AND TYPE(S).

Model	Type	Power Requirement	Remarks
PDP-504CMX	LUC/1	AC100 - 120V	
PDP-434CMX	LUC/1	AC100 - 120V	

This service manual should be used together with the following manual(s).

Model No.	Order No.	Remarks
PDP-504CMX PDP-434CMX	ARP3242	SCHEMATIC DIAGRAM, PCB CONNECTION DIAGRAM

HOW TO DISTINGUISH THE CURRENT MODEL FROM THE PREVIOUS MODEL

• **Serial No.**

Previous model
(PDP-504CMX/LUC)
(PDP-434CMX/LUC)

Current model
(PDP-504CMX/LUC/1)
(PDP-434CMX/LUC/1)

CFSS00001JP

Number for identification of the previous model

CFSS10001JP PDP-504CMX/1

Number for identification of the current model

• Name label, Barcode label

Number for identification of the current model



For details, see the next section "How to distinguish the current model from the previous model."



For details, refer to "Important Check Points for Good Servicing".

HOW TO DISTINGUISH THE CURRENT MODEL FROM THE PREVIOUS MODEL

A ■ Label reading

You can distinguish the current model from the previous model by referring to the model-name label and the barcode label.

● On the serial label

Current model
(PDP-504CMX/LUC/1)
(PDP-434CMX/LUC/1)

CFSS10001JP PDP-504CMX/1

"/1" is added to the model name.
1: Current model

Previous model
(PDP-504CMX/LUC)
(PDP-434CMX/LUC)

CFSS00001JP

0: Previous model

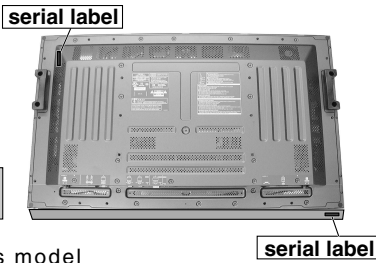

● On the barcode label

Current model : 1
Previous model : 0

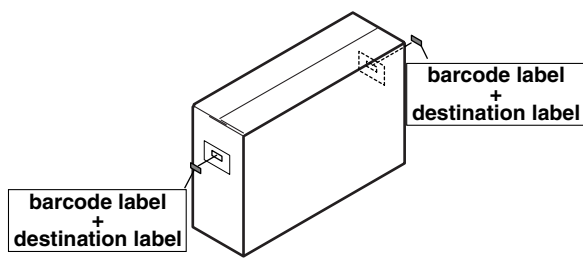

■ Distinction of PC boards

Some PC boards of the previous model are incompatible with the current model. Do NOT mount a PC board of the previous model in the current model, as it may cause a failure. When ordering a PC board, be sure to check the part number correctly.

On a PC board of the current model, "G5" is marked, as shown below.

Note: The photo is from a 50-inch model, but G5 markings are provided in exactly the same way as with the 50-inch model.

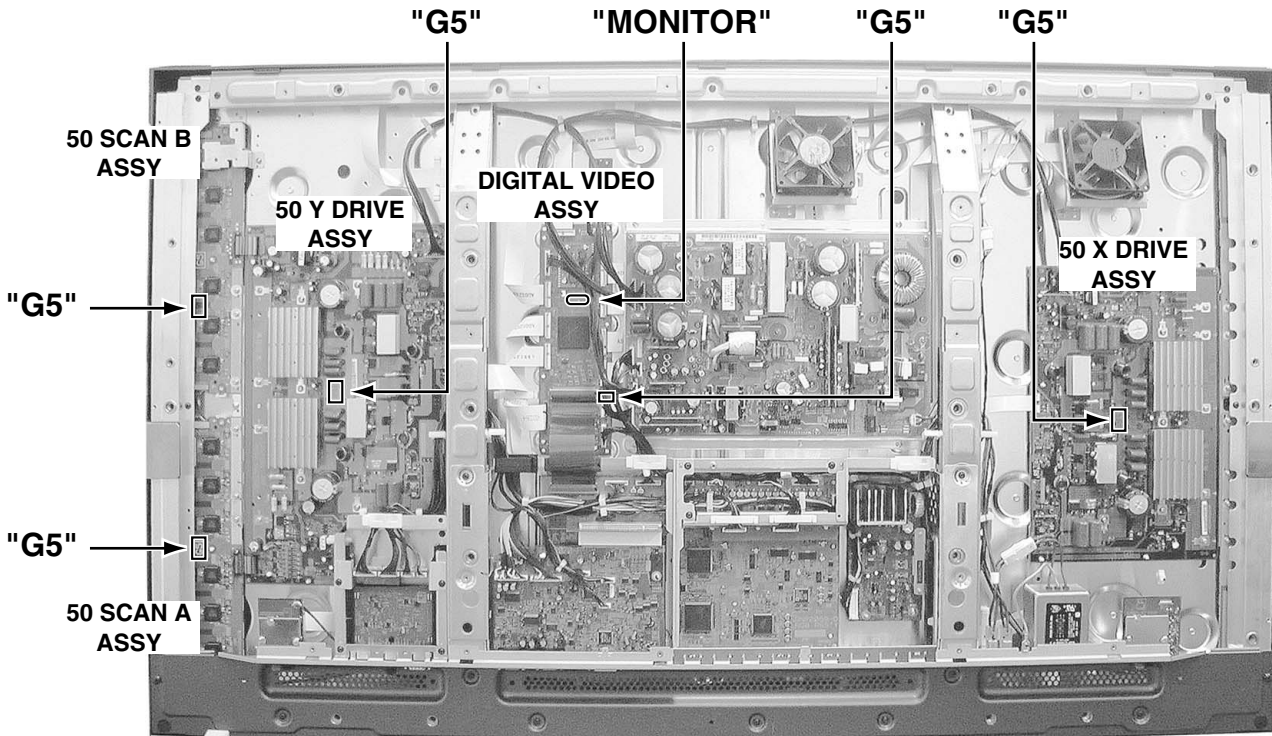

PDP-504CMX/1



This service manual is intended for qualified service technicians ; it is not meant for the casual do-it-yourselfer. Qualified technicians have the necessary test equipment and tools, and have been trained to properly and safely repair complex products such as those covered by this manual. Improperly performed repairs can adversely affect the safety and reliability of the product and may void the warranty. If you are not qualified to perform the repair of this product properly and safely, you should not risk trying to do so and refer the repair to a qualified service technician.



WARNING

This product contains lead in solder and certain electrical parts contain chemicals which are known to the state of California to cause cancer, birth defects or other reproductive harm.

Health & Safety Code Section 25249.6 - Proposition 65



NOTICE

(FOR CANADIAN MODEL ONLY)

Fuse symbols  (fast operating fuse) and/or  (slow operating fuse) on PCB indicate that replacement parts must be of identical designation.

REMARQUE

(POUR MODÈLE CANADIEN SEULEMENT)

Les symboles de fusible  (fusible de type rapide) et/ou  (fusible de type lent) sur CCI indiquent que les pièces de remplacement doivent avoir la même désignation.

SAFETY PRECAUTIONS

NOTICE : Comply with all cautions and safety related notes located on or inside the cabinet and on the chassis.

The following precautions should be observed :

1. When service is required, even though the PDP UNIT an isolation transformer should be inserted between the power line and the set in safety before any service is performed.
2. When replacing a chassis in the set, all the protective devices must be put back in place, such as barriers, nonmetallic knobs, adjustment and compartment covershields, isolation resistor-capacitor, etc.
3. When service is required, observe the original lead dress. Extra precaution should be taken to assure correct lead dress in the high voltage circuitry area.
4. Always use the manufacture's replacement components. Especially critical components as indicated on the circuit diagram should not be replaced by other manufacture's. Furthermore where a short circuit has occurred, replace those components that indicate evidence of overheating.
5. Before returning a serviced set to the customer, the service technician must thoroughly test the unit to be certain that it is completely safe to operate without danger of electrical shock, and be sure that no protective device built into the set by the manufacture has become defective, or inadvertently defeated during servicing. Therefore, the following checks should be performed for the continued protection of the customer and servicetechnician.
 6. Perform the following precautions against unwanted radiation and rise in internal temperature.
 - Always return the internal wiring to the original styling.
 - Attach parts (Gasket, Ferrite Core, Ground, Rear Cover, Shield Case etc.) surely after disassembly.
 7. Perform the following precautions for the PDP panel.
 - When the front case is removed, make sure nothing hits the panel face, panel corner, and panel edge (so that the glass does not break).
 - Make sure that the panel vent does not break. (Check that the cover is attached.)
 - Handle the FPC connected to the panel carefully. Twisting or pulling the FPC when connecting it to the connector will cause it to peel off from the panel.
 8. Pay attention to the following.
 - When the front case is removed, infrared ray is radiated and may disturb reception of the remote control unit.
 - Pay extreme caution when the front case and rear panel are removed because this may cause a high risk of disturbance to TVs and radios in the surrounding.

Leakage Current Cold Check

With the AC plug removed from an AC power source, place a jumper across the two plug prongs. Turn the AC power switch on. Using an insulation tester (DC 500V), connect one lead to the jumpered AC plug and touch the other lead to each exposed metal part (input/output terminals, screwheads, metal overlays, control shafts, etc.), particularly any exposed metal part having a return path to the chassis. Exposed metal parts having a return path to the chassis should have a minimum resistor reading of $0.3M\Omega$ and a maximum resistor reading of $5M\Omega$. Any resistor value below or above this range indicates an abnormality which requires corrective action. Exposed metal parts not having a return path to the chassis will indicate an open circuit.

Leakage Current Hot Check

Plug the AC line cord directly into an AC power source (do not use an isolation transformer for this check).

Turn the AC power switch on.

Using a "Leakage Current Tester (Simpson Model 229 equivalent)", measure for current from all exposed metal parts of the cabinet (input/output terminals, screwheads, metal overlays, control shaft, etc.), particularly any exposed metal part having a return path to the chassis, to a known earth ground (water pipe, conduit, etc.). Any current measured must not exceed $0.5mA$.

PRODUCT SAFETY NOTICE

Many electrical and mechanical parts in PIONEER set have special safety related characteristics. These are often not evident from visual inspection nor the protection afforded by them necessarily can be obtained by using replacement components rated for higher voltage, wattage, etc. Replacement parts which have these special safety characteristics are identified in this Service Manual.

Electrical components having such features are identified by marking with a \triangle on the schematics and on the parts list in this Service Manual.

The use of a substitute replacement component which does not have the same safety characteristics as the PIONEER recommended replacement one, shown in the parts list in this Service Manual, may create shock, fire or other hazards.

Product Safety is continuously under review and new instructions are issued from time to time. For the latest information, always consult the current PIONEER Service Manual. A subscription to, or additional copies of, PIONEER Service Manual may be obtained at a nominal charge from PIONEER.

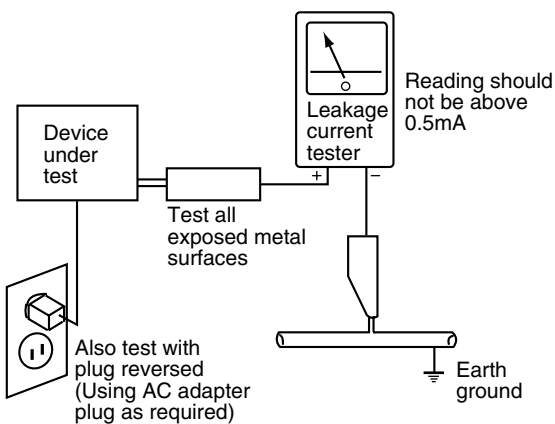

AC Leakage Test



ANY MEASUREMENTS NOT WITHIN THE LIMITS OUTLINED ABOVE ARE INDICATIVE OF A POTENTIAL SHOCK HAZARD AND MUST BE CORRECTED BEFORE RETURNING THE SET TO THE CUSTOMER.

■ Charged Section

The places where the commercial AC power is used without passing through the power supply transformer. If the places are touched, there is a risk of electric shock. In addition, the measuring equipment can be damaged if it is connected to the GND of the charged section and the GND of the non-charged section while connecting the set directly to the commercial AC power supply. Therefore, be sure to connect the set via an insulated transformer and supply the current.

1. Power Cord
2. AC Inlet with Filter
3. Power Switch (S1)
4. Fuse (In the POWER SUPPLY Unit)
5. STB Transformer and Converter Transformer (In the POWER SUPPLY Unit)
6. Other primary side of the POWER SUPPLY Unit

● 50 inch model

-  : Part is Charged Section.
-  : Part is the High Voltage Generating Points other than the Charged Section.

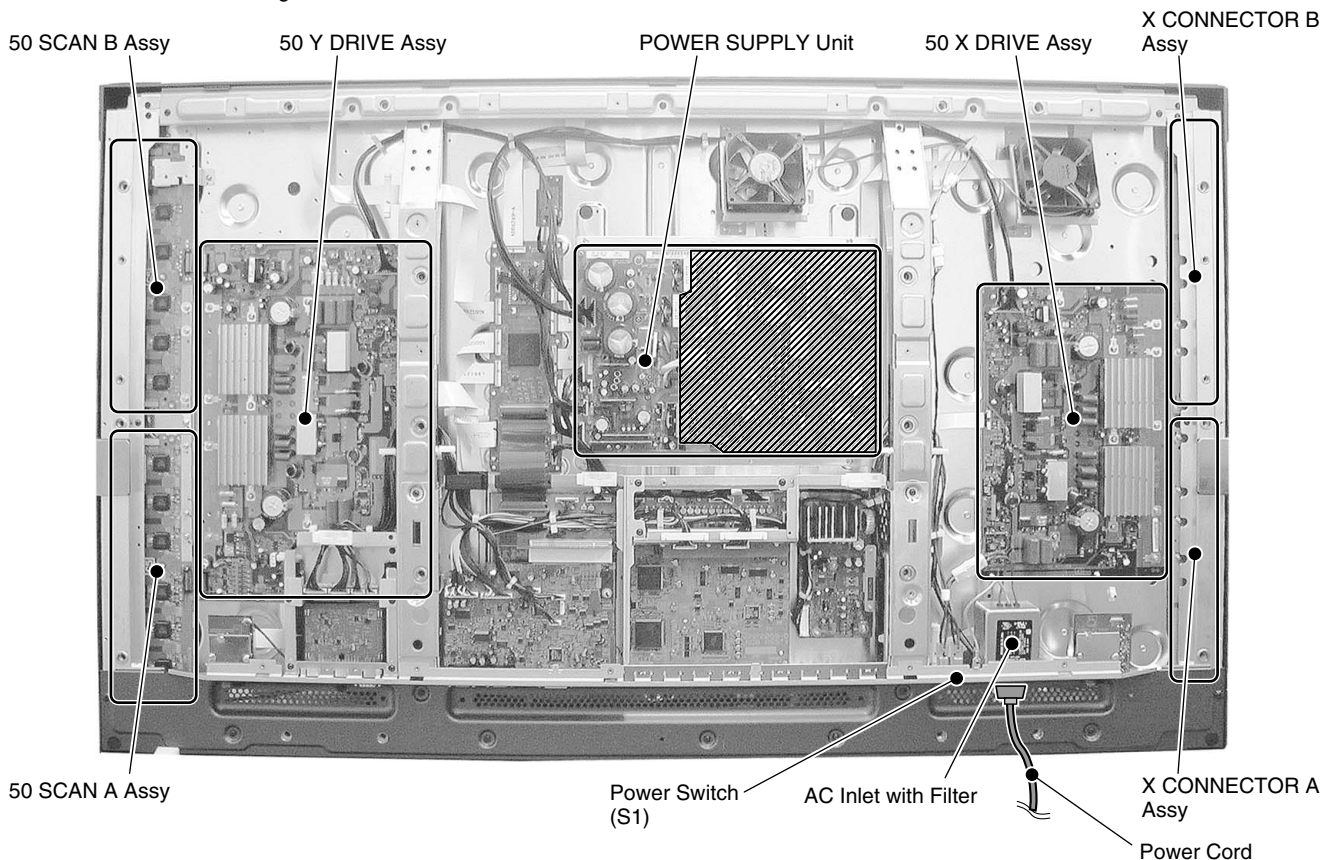

Fig.1 Charged Section and High Voltage Generating Point (Rear view)

■ High Voltage Generating Point

The places where voltage is 100 V or more besides the live parts are described above. You must not touch them, since there is risk of electric shock.

The VSUS voltage remains for several minutes after the power to the unit is turned off. These places must not be touched until about 10 minutes after the power is turned off, or it is confirmed with a tester that there is no residual VSUS voltage.

1. POWER SUPPLY Unit.....(223V)
2. 50 X DRIVE Assy(-230V to 223V)
3. 50 Y DRIVE Assy(353V)
4. 50 SCAN A Assy(353V)
5. 50 SCAN B Assy(353V)
6. X CONNECTOR A Assy(-230V to 223V)
7. X CONNECTOR B Assy (-230V to 223V)

Discharge the VSUS voltage, as shown below:

[Method for discharging the VSUS voltage]

1. Set DRF_SW on the DIGITAL VIDEO Assy to ON (Drive OFF status). *1, *2
2. Leave the switch at that position for about 20-30 seconds.
3. If the power is on, turn it off. Then return DRF_SW to the OFF position. *3

Notes

- *1: You can also set the unit to "Drive OFF status" by sending the "DRF" RS232C command from the PC.
- *2: DRF_SW can be switched whether the power is on or off.
- *3: Power-down will occur if DRF_SW is set to OFF while the power is on. (See "7.1.5 POWER ON/OFF FUNCTION FOR THE LARGE-SIGNAL SYSTEM".)

■Charged Section

The places where the commercial AC power is used without passing through the power supply transformer. If the places are touched, there is a risk of electric shock. In addition, the measuring equipment can be damaged if it is connected to the GND of the charged section and the GND of the non-charged section while connecting the set directly to the commercial AC power supply. Therefore, be sure to connect the set via an insulated transformer and supply the current.

1. Power Cord
2. AC Inlet with Filter
3. Power Switch (S1)
4. Fuse (In the POWER SUPPLY Unit)
5. STB Transformer and Converter Transformer (In the POWER SUPPLY Unit)
6. Other primary side of the POWER SUPPLY Unit

■High Voltage Generating Point

The places where voltage is 100 V or more besides the live parts are described above. You must not touch them, since there is risk of electric shock.

The VSUS voltage remains for several minutes after the power to the unit is turned off. These places must not be touched until about 10 minutes after the power is turned off, or it is confirmed with a tester that there is no residual VSUS voltage.

1. POWER SUPPLY Unit.....(215V)
2. 43 X DRIVE Assy(-235V to 215V)
3. 43 Y DRIVE Assy(345V)
4. 43 SCAN A Assy (345V)
5. 43 SCAN B Assy (345V)
6. X CONNECTOR A Assy(-235V to 215V)
7. X CONNECTOR B Assy (-235V to 215V)

Discharge the VSUS voltage, as shown below:



[Method for discharging the VSUS voltage]

1. Set DRF_SW on the DIGITAL VIDEO Assy to ON (Drive OFF status). *1, *2
2. Leave the switch at that position for about 20-30 seconds.
3. If the power is on, turn it off. Then return DRF_SW to the OFF position. *3

Notes

- *1: You can also set the unit to "Drive OFF status" by sending the "DRF" RS232C command from the PC.
- *2: DRF_SW can be switched whether the power is on or off.
- *3: Power-down will occur if DRF_SW is set to OFF while the power is on. (See "7.1.5 POWER ON/OFF FUNCTION FOR THE LARGE-SIGNAL SYSTEM".)

● 43 inch model

-  : Part is Charged Section.
-  : Part is the High Voltage Generating Points other than the Charged Section.

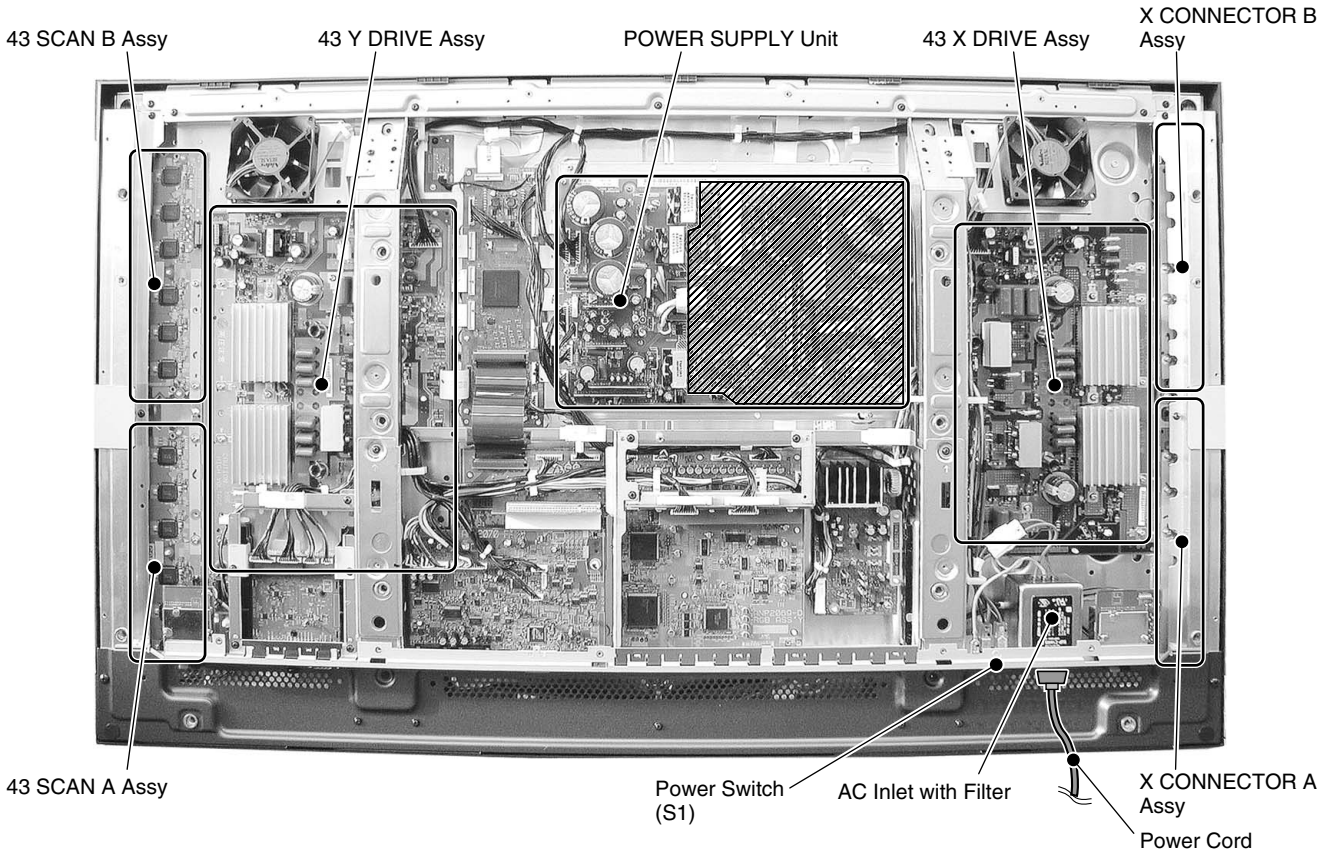

Fig.2 Charged Section and High Voltage Generating Point (Rear view)

[Important Check Points for Good Servicing]

In this manual, procedures that must be performed during repairs are marked with the below symbol. Please be sure to confirm and follow these procedures.

1. Product safety



Please conform to product regulations (such as safety and radiation regulations), and maintain a safe servicing environment by following the safety instructions described in this manual.

- ① Use specified parts for repair.

Use genuine parts. Be sure to use important parts for safety.

- ② Do not perform modifications without proper instructions.

Please follow the specified safety methods when modification (addition/change of parts) is required due to interferences such as radio/TV interference and foreign noise.

- ③ Make sure the soldering of repaired locations is properly performed.

When you solder while repairing, please be sure that there are no cold solder and other debris. Soldering should be finished with the proper quantity. (Refer to the example)

- ④ Make sure the screws are tightly fastened.

Please be sure that all screws are fastened, and that there are no loose screws.

- ⑤ Make sure each connectors are correctly inserted.

Please be sure that all connectors are inserted, and that there are no imperfect insertion.

- ⑥ Make sure the wiring cables are set to their original state.

Please replace the wiring and cables to the original state after repairs. In addition, be sure that there are no pinched wires, etc.

- ⑦ Make sure screws and soldering scraps do not remain inside the product.

Please check that neither solder debris nor screws remain inside the product.

- ⑧ There should be no semi-broken wires, scratches, melting, etc. on the coating of the power cord.

Damaged power cords may lead to fire accidents, so please be sure that there are no damages. If you find a damaged power cord, please exchange it with a suitable one.

- ⑨ There should be no spark traces or similar marks on the power plug.

When spark traces or similar marks are found on the power supply plug, please check the connection and advise on secure connections and suitable usage. Please exchange the power cord if necessary.

- ⑩ Safe environment should be secured during servicing.

When you perform repairs, please pay attention to static electricity, furniture, household articles, etc. in order to prevent injuries. Please pay attention to your surroundings and repair safely.

2. Adjustments



To keep the original performance of the products, optimum adjustments and confirmation of characteristics within specification. Adjustments should be performed in accordance with the procedures/instructions described in this manual.

3. Lubricants, Glues, and Replacement parts



Use grease and adhesives that are equal to the specified substance. Make sure the proper amount is applied.

4. Cleaning



For parts that require cleaning, such as optical pickups, tape deck heads, lenses and mirrors used in projection monitors, proper cleaning should be performed to restore their performances.

5. Shipping mode and Shipping screws



To protect products from damages or failures during transit, the shipping mode should be set or the shipping screws should be installed before shipment. Please be sure to follow this method especially if it is specified in this manual.

COTENTS

- SAFETY INFORMATION..... 3
- 1. SPECIFICATIONS..... 9
- A 2. EXPLODED VIEWS AND PARTS LIST 12
 - 2.1 PACKING for PDP-504CMX and PDP-434CMX models..... 12
 - 2.1.1 PACKING 12
 - 2.2 PDP-504CMX model..... 14
 - 2.2.1 CHASSIS SECTION (1) 14
 - 2.2.2 CHASSIS SECTION (2) 16
 - 2.2.3 FRAME SECTION 18
 - 2.2.4 TERMINAL PANEL and REAR SECTION 20
 - 2.2.5 FRONT SECTION 22
 - 2.2.6 PANEL CHASSIS (50) ASSY (AWU1111) 24
 - 2.2.7 PDP SERVICE ASSY (AWU1114) 25
 - 2.3 PDP-434CMX model..... 26
 - 2.3.1 CHASSIS SECTION (1) 26
 - 2.3.2 CHASSIS SECTION (2) 28
 - 2.3.3 FRAME SECTION 30
 - 2.3.4 TERMINAL PANEL and REAR SECTION 32
 - 2.3.5 FRONT SECTION 34
 - 2.3.6 PANEL CHASSIS (43) ASSY (AWU1112) 36
 - 2.3.7 PDP SERVICE ASSY (AWU1115) 37
 - 2.4 MULTI BASE SECTION for PDP-504CMX and PDP-434CMX models 38
 - 2.4.1 MULTI BASE SECTION..... 38
- B 3. BLOCK DIAGRAM AND SCHEMATIC DIAGRAM (Refer to “Service Manual: ARP3242”) 40
 - 3.1 BLOCK DIAGRAM 40
 - 3.1.1 OVERALL BLOCK DIAGRAM (1/2) for PDP-504CMX..... 40
 - C 3.1.2 OVERALL BLOCK DIAGRAM (1/2) for PDP-434CMX 42
 - 3.1.3 OVERALL BLOCK DIAGRAM (2/2) 44
 - 3.1.4 SIGNAL ROUTE 46
 - 3.1.5 50 Y DRIVE ASSY 47
 - 3.1.6 43 Y DRIVE ASSY 48
 - 3.1.7 50 X DRIVE ASSY 49
 - 3.1.8 43 X DRIVE ASSY 50
 - 3.1.9 DIGITAL VIDEO ASSY..... 51
 - 3.1.10 AV I/O ASSY 52
 - 3.1.11 RGB ASSY 53
 - 3.1.12 AUDIO AMP and COMM SLOT ASSYS..... 54
 - D 3.2 WAVEFORMS..... 55
 - 3.3 VOLTAGES 60
- 4. PCB CONNECTION DIAGRAM (Refer to “Service Manual: ARP3242”) 68
- 5. PCB PARTS LIST 68
- 6. ADJUSTMENT 88
 - 6.1 ADJUSTMENT REQUIRED WHEN THE SET IS REPAIRED OR REPLACED 88
 - 6.2 DRIVE ASSY ADJUSTMENT 89
 - 6.3 SERVICE FACTORY MODE 90
 - 6.4 HOW TO ENTER FACTORY MODE 91
 - 6.5 COMMAND DESCRIPTION..... 114
 - 6.6 METHOD FOR REPLACING THE SERVICE PANEL ASSY..... 124
- E 7. GENERAL INFORMATION 125
 - 7.1 DIAGNOSIS 125
 - 7.1.1 CONFIGURATION OF THE PC BOARD 125
 - 7.1.2 DIAGNOSIS FOR SHUTDOWN AND POWER-DOWN BY LED 126
 - 7.1.3 PROCESSING AT THE TIME OF ABNORMALITIES 133
 - 7.1.4 TEMPERATURE COMPENSATION OF DRIVE SYSTEM VOLTAGE 133
 - 7.1.5 POWER ON/OFF FUNCTION FOR THE LARGE-SIGNAL SYSTEM 134
 - 7.1.6 BACKUP THE ADJUSTMENT VALUES FOR THE MAIN UNIT 135
 - 7.1.7 TROUBLESHOOTING 137
 - 7.1.8 DISASSEMBLY 139
 - 7.2 IC INFORMATION 145
- F 8. PANEL FACILITIES..... 186

1. SPECIFICATIONS

■ PLASMA DISPLAY (PDP-504CMX)

General

Light emission panel 50 inch plasma AC display panel
 109.8 (W) x 62.1 (H) x 126.1 (diagonal) cm
 Number of pixels 1280 x 768
 Power supply AC 100 - 120 V, 50/60 Hz
 Rated current 3.6 A - 2.9A
 Standby power consumption 0.8 W
 External dimension 1218 (W) x 714 (H) x 98 (D) mm
 47-31/32 (W) x 28-1/8 (H) x 3-7/8 (D) in.
 (including display stand)
 1218 (W) x 737 (H) x 300 (D) mm
 47-31/32 (W) x 29-1/32 (H) x 11-13/16 (D) in.
 Weight 41.0kg
 (including display stand) 41.6 kg
 Operating temperature range..... 0 to 40 °C
 Operating Humidity 20 to 80 %
 Operating atmospheric pressure range 760 to 1100 hPa

Input/output

Video

INPUT 1

Input

Mini D-sub 15 pin (socket connector)
 RGB signal (G ON SYNC compatible)
 RGB ... 0.7 Vp-p/75 Ω/no sync.
 HD/VS, VD ... TTL level
 /positive and negative polarity
 /2.2 kΩ
 G ON SYNC
 ... 1 Vp-p/75 Ω/negative sync.
 *Compatible with Microsoft's Plug & Play
 (VESA DDC1/2B)

Output

Mini D-sub 15 pin (socket connector)
 75 Ω/with buffer

INPUT 2

Input

DVI-D 24-pin connector
 Digital RGB signal (DVI compliant
 TMDS signal)
 *Compatible with Microsoft "Plug & Play"
 (VESA DDC 2B)

Audio

Input

AUDIO INPUT (for INPUT 1)
 Stereo mini jack
 L/R ... 500mVrms/more than 10 kΩ

AUDIO INPUT (for INPUT 2)
 Stereo mini jack
 L/R ... 500mVrms/more than 10 kΩ

Output

AUDIO OUTPUT
 Stereo mini jack
 L/R ... 500mVrms (max)/less than 5 kΩ

SPEAKER
 L/R ... 8 – 16 Ω/7W +7W (at 8 Ω)

Control

RS-232CD-sub 9 pin (pin connector)
 COMBINATION IN/OUT..... Mini DIN 6 pin (x2)

Accessories

Power cord 1
 Remote control unit 1
 Remote control unit holder 1
 AA (R6) batteries 2
 Cleaning cloth (for screen) 1
 Speed clamps 2
 Bead bands 2
 Warranty 1
 Operating Instructions 1
 Display stands 2
 Washers 2
 Hex hole bolts (M8X40) 2

Due to improvements, specifications and design are subject to change without notice.

● Accessories

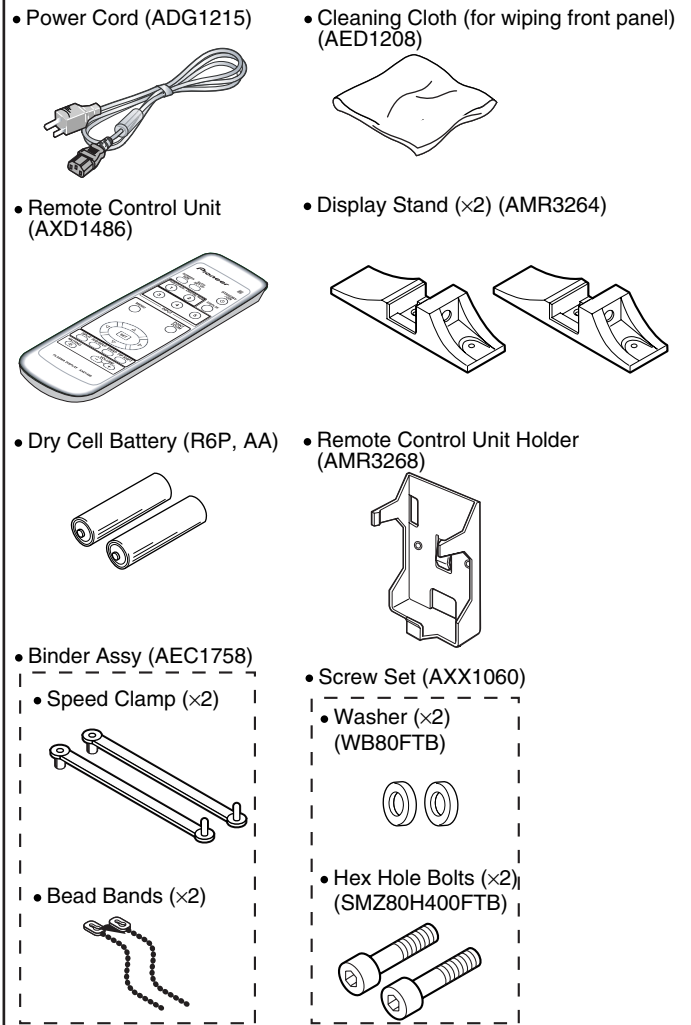

■ PLASMA DISPLAY (PDP-434CMX)

A General

Light emission panel “43-inch” AC Plasma Panel
 95.2 (W) x 53.6 (H) x 109.3 (diagonal) cm
 Number of pixels 1024 x 768
 Power supply AC 100 - 120 V, 50/60 Hz
 Rated current 2.98 A - 2.48 A
 Standby power consumption 0.8 W
 External dimension 1070 (W) x 630 (H) x 98 (D) mm
 42-1/8 (W) x 24-13/16 (H) x 3-7/8 (D)

(D: Not including handles) in.
 (including display stand)

..... 1070 (W) x 653 (H) x 300 (D) mm
 42-1/8 (W) x 25-23/32 (H) x 11-13/16 (D) in.

Weight 32.5kg
 (including display stand) 33.1 kg (73 lbs.)
 Operating temperature range..... 0 to 40 °C
 Operating Humidity 20 to 80 %
 Operating atmospheric pressure range 760 to 1100 hPa

Input/output Video

INPUT 1

Input

Mini D-sub 15 pin (socket connector)
 RGB signal (G ON SYNC compatible)
 RGB ... 0.7 Vp-p/75 Ω/no sync.
 HD/VS, VD ... TTL level
 /positive and negative polarity
 /2.2 kΩ

G ON SYNC

... 1 Vp-p/75 Ω/negative sync.

*Compatible with Microsoft's Plug & Play
 (VESA DDC1/2B)

Output

Mini D-sub 15 pin (socket connector)
 75 Ω/with buffer

INPUT 2

Input

DVI-D 24-pin connector
 Digital RGB signal (DVI compliant
 TMDS signal)
 *Compatible with Microsoft “Plug & Play”
 (VESA DDC 2B)

Audio

Input

AUDIO INPUT (for INPUT 1)
 Stereo mini jack
 L/R ... 500mVrms/more than 10 kΩ

AUDIO INPUT (for INPUT 2)
 Stereo mini jack
 L/R ... 500mVrms/more than 10 kΩ

Output

AUDIO OUTPUT
 Stereo mini jack
 L/R ... 500mVrms (max)/less than 5 kΩ

SPEAKER
 L/R ... 8 – 16 Ω/7W +7W (at 8 Ω)

Control

RS-232CD-sub 9 pin (pin connector)
 COMBINATION IN/OUT..... Mini DIN 6 pin (x2)

Accessories

Power cord 1
 Remote control unit 1
 Remote control unit holder 1
 AA (R6) batteries 2
 Cleaning cloth (for screen) 1
 Speed clamps 2
 Bead bands 2
 Warranty 1
 Operating Instructions 1
 Display stands 2
 Washers 2
 Hex hole bolts (M8X40) 2

Due to improvements, specifications and design are subject to change without notice.

● Accessories

- Power Cord (ADG1215)
- Cleaning Cloth (for wiping front panel) (AED1208)
- Remote Control Unit (AXD1486)
- Display Stand (x2) (AMR3264)
- Dry Cell Battery (R6P, AA)
- Remote Control Unit Holder (AMR3268)
- Binder Assy (AEC1758)
- Screw Set (AXX1060)
- Speed Clamp (x2)
- Washer (x2) (WB80FTB)
- Bead Bands (x2)
- Hex Hole Bolts (x2) (SMZ80H400FTB)

■

5

■

6

■

7

■

8

■

A

■

B

■

C

■

D

■

E

■

F

■

5

■

6

PDP-504CMX/1

■



7

■

8

■

2. EXPLODED VIEWS AND PARTS LIST

- NOTES:
- Parts marked by "NSP" are generally unavailable because they are not in our Master Spare Parts List.
 - The  mark found on some component parts indicates the importance of the safety factor of the part. Therefore, when replacing, be sure to use parts of identical designation.
 - Screws adjacent to  mark on product are used for disassembly.
 - For the applying amount of lubricants or glue, follow the instructions in this manual. (In the case of no amount instructions, apply as you think it appropriate.)

2.1 PACKING for PDP-504CMX and PDP-434CMX models

2.1.1 PACKING

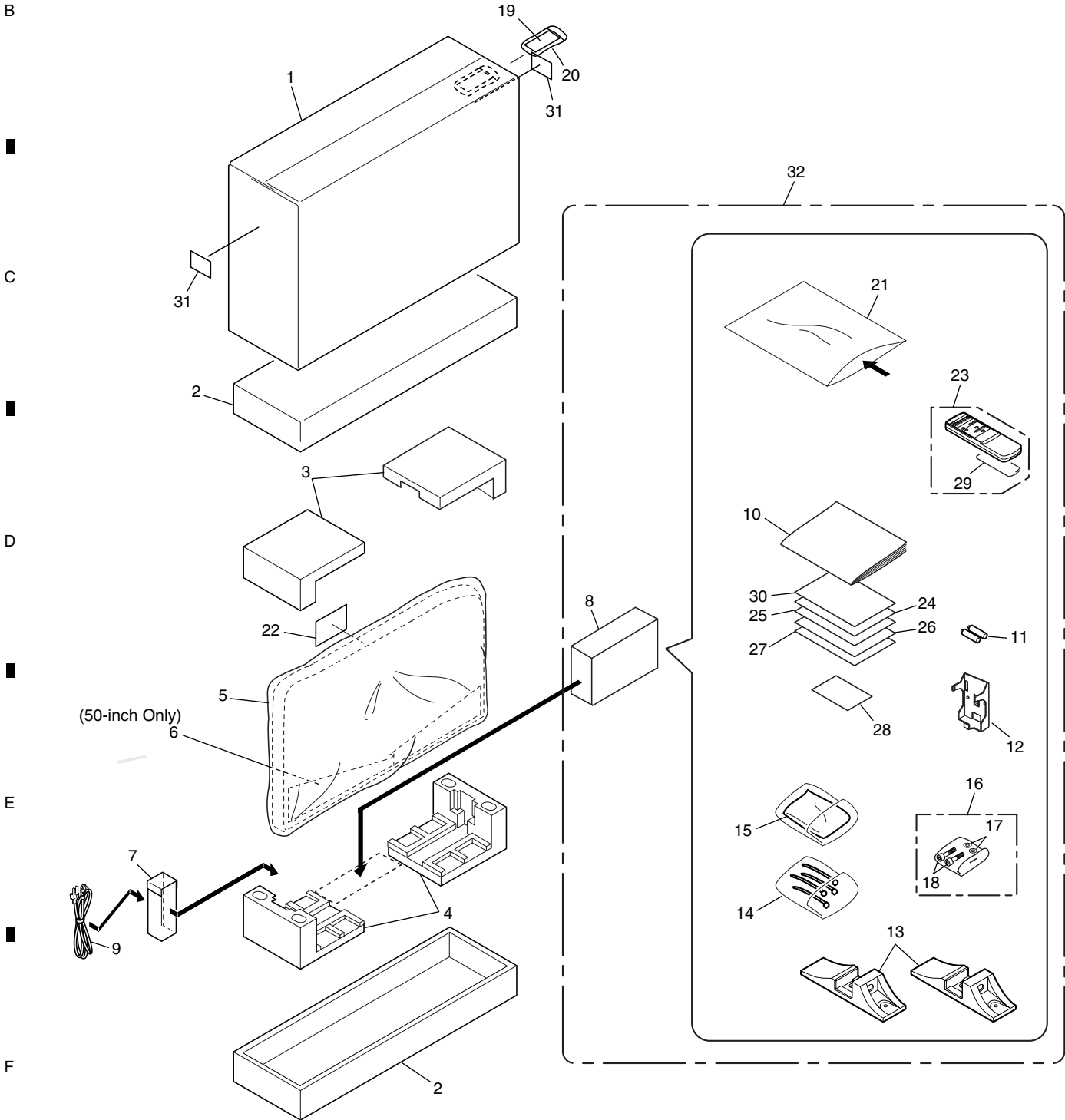

PACKING Parts List

<u>Mark No.</u>	<u>Description</u>	<u>Part No.</u>	<u>Mark No.</u>	<u>Description</u>	<u>Part No.</u>
1	Upper Carton	See Contrast table(2)	21	Vinyl Bag	AHG1330
2	Under Carton	See Contrast table(2)	22	Caution Sheet	ARM1201
3	Pad	See Contrast table(2)	23	Remote Control Unit	AXD1486
4	Pad	See Contrast table(2)	24	Caution Sheet	ARM1245
5	Mirror Mat	AHG1284	25	Plasma Caution Sheet	ARM1147
6	Front Sheet	See Contrast table(2)	26	Caution Sheet	ARM1200
7	Cord Case	AHC1037	27	Image Caution Sheet	ARM1220
8	Accessory Case Assy	AHC1040	NSP 28	Warranty Card	ARY1146
⚠ 9	AC Power Cord	ADG1215	29	Battery Cover	AZN2462
10	Operating Instructions (English/ French/ Japanese)	ARD1055	30	Image Stick Caution	ARM1240
NSP 11	Battery (R6P, AA)	VEM1031	31	Destination Label	AAX3152
12	Reomote Control Holder	AMR3268	NSP 32	Accessory C. Assy4cmx	AXX1065
13	Display Stand	AMR3264			
14	Binder Assy (Speed Clamp x2, Bead Band x2)	AEC1758			
15	Wiping Cloth (for screen)	AED1208			
16	Screws Set	AXX1060			
17	Washer	WB80FTB			
18	Bolt	SMZ80H400FTB			
NSP 19	Warranty Card	ARY1093			
NSP 20	Vinyl Bag	AHG-195			

(2) CONTRAST TABLE

PDP-504CMX/LUC/1 and PDP-434CMX/LUC/1 are constructed the same except for the following:

Mark	No.	Symbol and Description	PDP-504CMX/ LUC/1	PDP-434CMX/ LUC/1
	1	Upper Carton (504CMX)	AHD3216	Not used
	1	Upper Carton (434CMX)	Not used	AHD3232
	2	Under Carton (504CMX)	AHD3037	Not used
	2	Under Carton (434CMX)	Not used	AHD3100
	3	Pad	AHA2280	AHA2282
	4	Pad	AHA2280	AHA2283
	6	Front Sheet	AHB1241	Not used

1 2 3 4

2.2 PDP-504CMX model

2.2.1 CHASSIS SECTION (1)

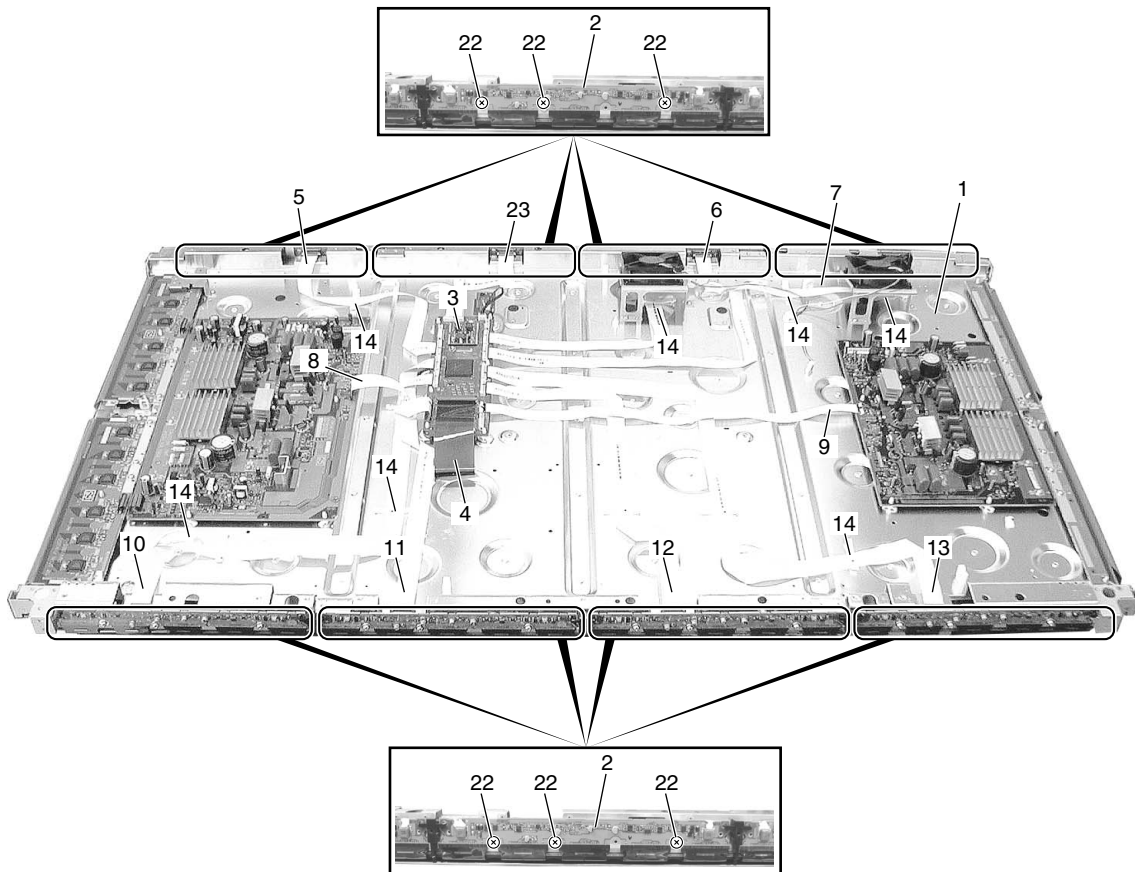
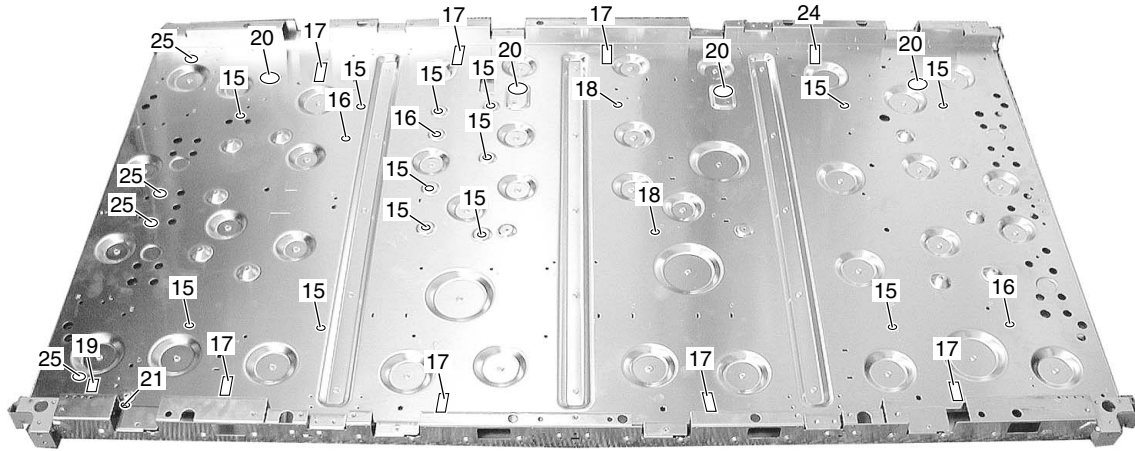

CHASSIS SECTION (1) parts List

<u>Mark No.</u>	<u>Description</u>	<u>Part No.</u>
NSP 1	P. Chassis (50) Assy	AWU1111
NSP 2	50 ADDRESS Assy	AWZ6870
3	DIGITAL VIDEO Assy	AWV2169
4	FPC (114P)	ADY1081
5	Flexible Cable (J201)	ADD1248
6	Flexible Cable (J203)	ADD1250
7	Flexible Cable (J204)	ADD1283
8	Flexible Cable (J209)	ADD1236
9	Flexible Cable (J210)	ADD1237
10	Flexible Cable (J205)	ADD1252
11	Flexible Cable (J206)	ADD1253
12	Flexible Cable (J207)	ADD1254
13	Flexible Cable (J208)	ADD1255
14	Flat Clamp	AEC1879
15	PCB Spacer	AEC1941
16	PCB Support	AEC1938
17	Wire Saddle	AEC1745
18	PCB Spacer	AEC1947
19	Wire Clip	AEC1948
20	Rear Corner Label	AAX3081
21	Screw	ABZ30P060FTC
22	Screw	VBB30P080FNI
23	Flexible Cable (J202)	ADD1249
24	Wire Clip	AEC1992
25	Edge Card Spacer	AEC1998

A

B

C

D

E

F

2.2.2 CHASSIS SECTION (2)

1

2

3

4

A

B

C

D

E

F

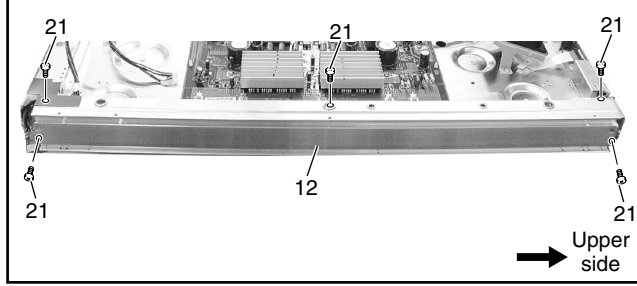
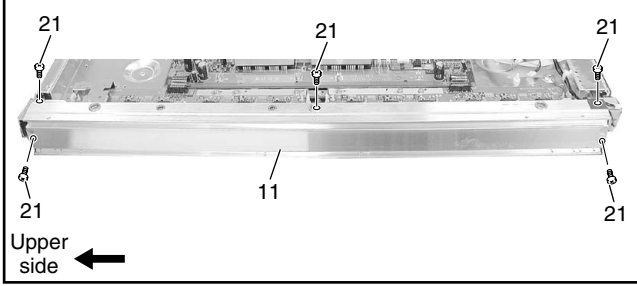
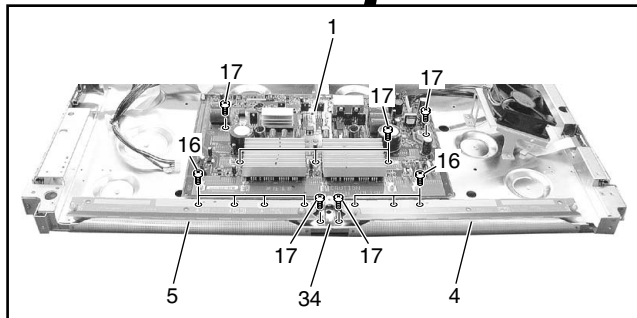
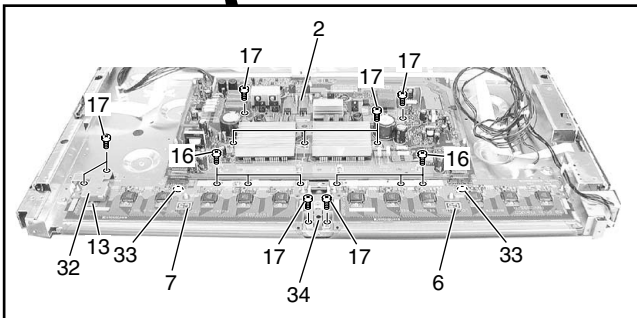
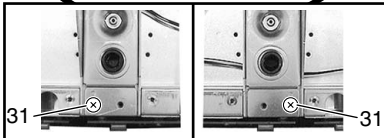
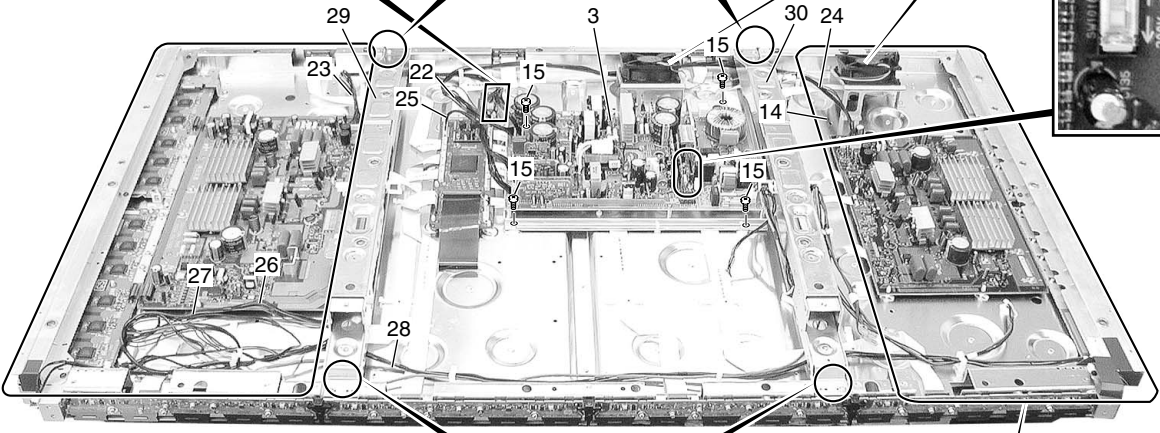
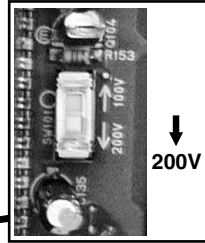
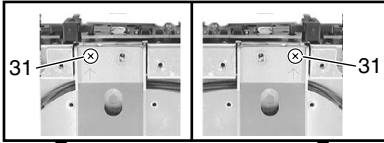
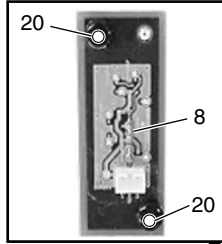
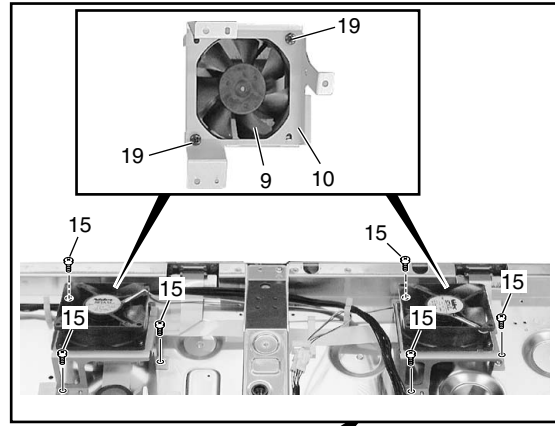

1

2

3

4

5 6 7 8

CHASSIS SECTION (2) parts List

<u>Mark No.</u>	<u>Description</u>	<u>Part No.</u>
1	50 X DRIVE Assy	AWZ6877
2	50 Y DRIVE Assy	AWV2082
⚠ 3	POWER SUPPLY Unit	AXY1083
NSP 4	X CONNECTOR B Assy	AWZ6881
NSP 5	X CONNECTOR A Assy	AWZ6880
NSP 6	50 SCAN A Assy	AWZ6878
NSP 7	50 SCAN B Assy	AWZ6879
8	PANEL SENSOR Assy	AWZ6872
9	Fan Motor (80 x 25)	AXM1044
10	Fan Angle	ANG2609
11	F. Chassis VL (50M)	ANA1753
12	F. Chassis VR (50M)	ANA1754
13	Silicon Sheet SC	AEH1080
14	Housing Wire (J117)	ADX2897
15	Screw	ABZ30P060FTC
16	Screw	PMB30P060FNI
17	Screw	VBB30P080FNI
18	•••••	
19	Screw	PPZ50P100FTB
20	Nylon Rivet	AEC1671
21	Screw	AMZ30P060FTB
22	3P Housing Wire (J109)	ADX2948
23	11P Housing Wire (J102)	ADX2950
24	12P Housing Wire (J103)	ADX2951
25	Wire A (J101)	ADX2945
26	WireD (J118)	ADX2898
27	Wire E (J119)	ADX2909
28	9P Housing Wire (J115)	ADX2895
29	SUB Frame L assy (50M)	ANG2596
30	SUB Frame R assy (50M)	ANG2598
31	Screw	AMZ30P080FTC
32	SCAN Heatsink	ANH1630
NSP 33	Card Spacer	AEC2013
34	Sel Plate	ANG2712

A
B
C
D
E
F

1 2 3 4

2.2.3 FRAME SECTION

A

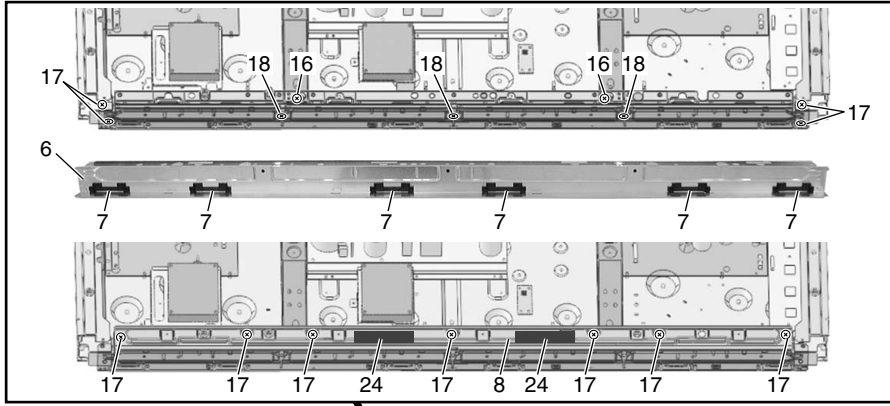

B

C

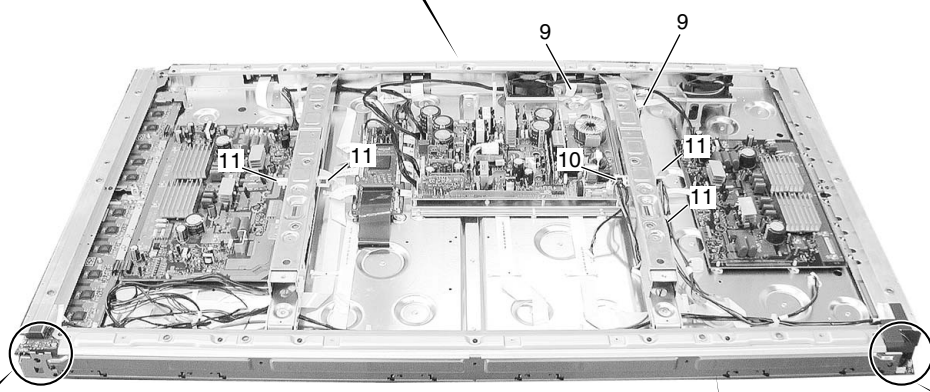

D

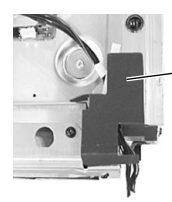
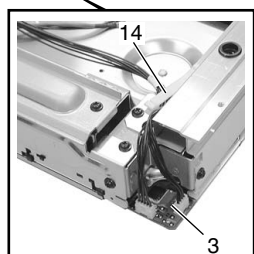
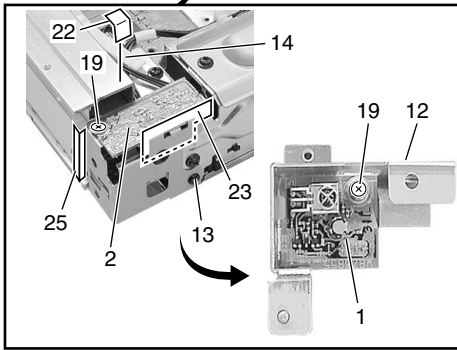

E

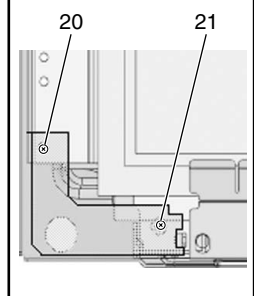
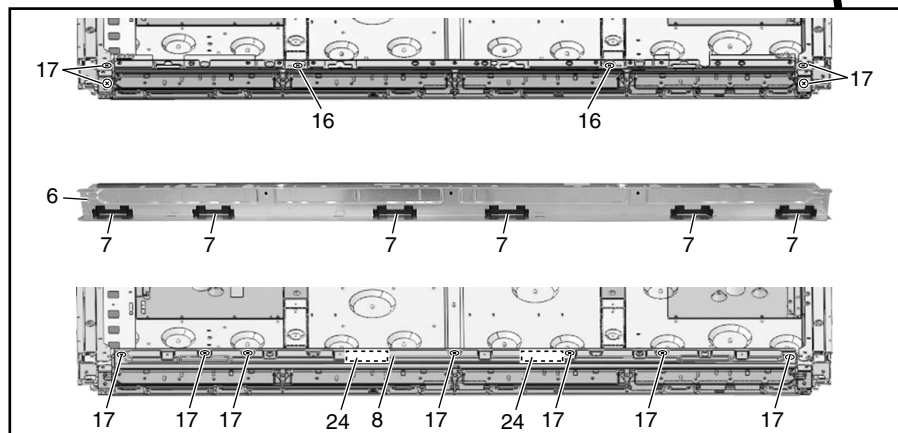

F

FRAME SECTION parts List

<u>Mark No.</u>	<u>Description</u>	<u>Part No.</u>	
1	IR RECEIVE Assy	AWZ6989	
2	KEY CONTROL Assy	AWZ6981	A
3	LED OPT Assy	AWZ6957	
4	•••••		
5	•••••		
6	Front Chassis H (50)	ANA1733	
7	Front Spacer (CMX)	AMR3384	
8	Rear Frame (50M)	ANG2602	
9	Wire Clip	AEC1948	
10	Wire Clip	AEC1992	
11	Wire Saddle	AEC1745	B
NSP 12	IR Holder	ANG2551	
13	Nylon Rivet	AEC1671	
14	Flat Clamp	AEC1879	
15	Enclosure Sheet 1	AMR3405	
16	Screw	AMZ30P080FTC	
17	Screw	AMZ30P060FTB	
18	Screw	BPZ30P080FTB	
19	Screw	ABZ30P060FTC	
20	Nylon Rivet	AEC1997	C
21	Screw	BBZ30P050FTC	
22	Enclosure Sheet 2 (V)	AMR3411	
23	Enclosure Sheet 3	AMR3407	
24	Gasket (CM)	ANK1748	
25	Gasket FC-IR	ANK1758	

2.2.4 TERMINAL PANEL and REAR SECTION

1

2

3

4

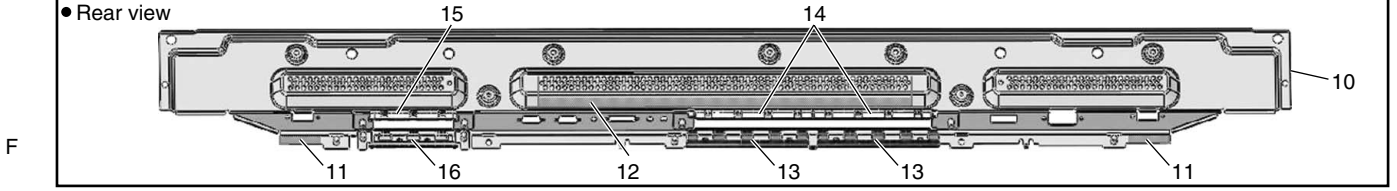
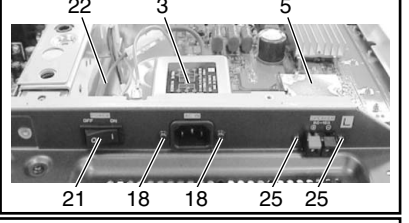
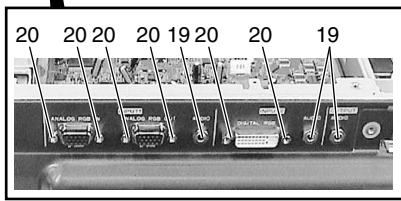
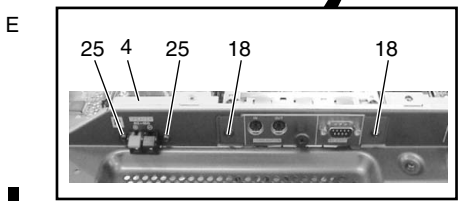
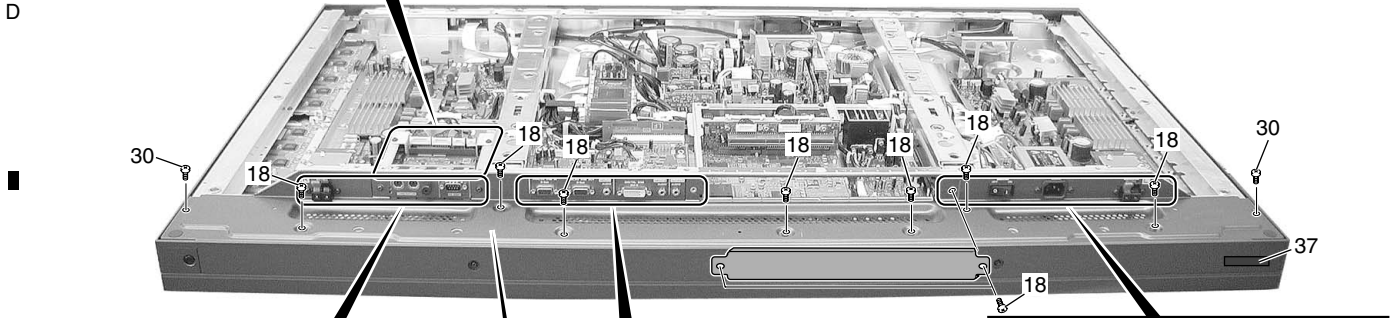
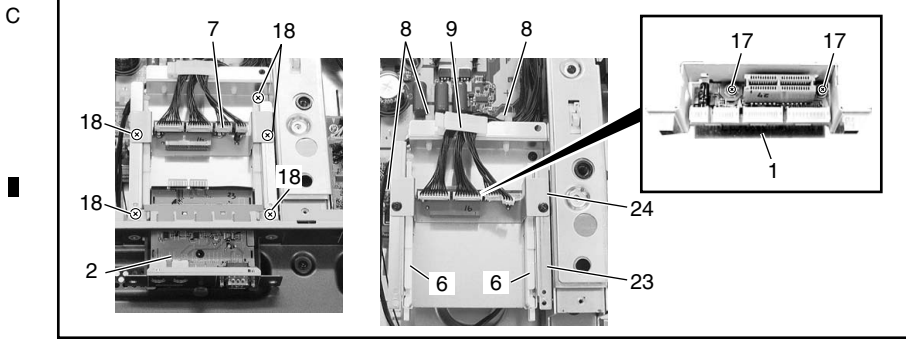
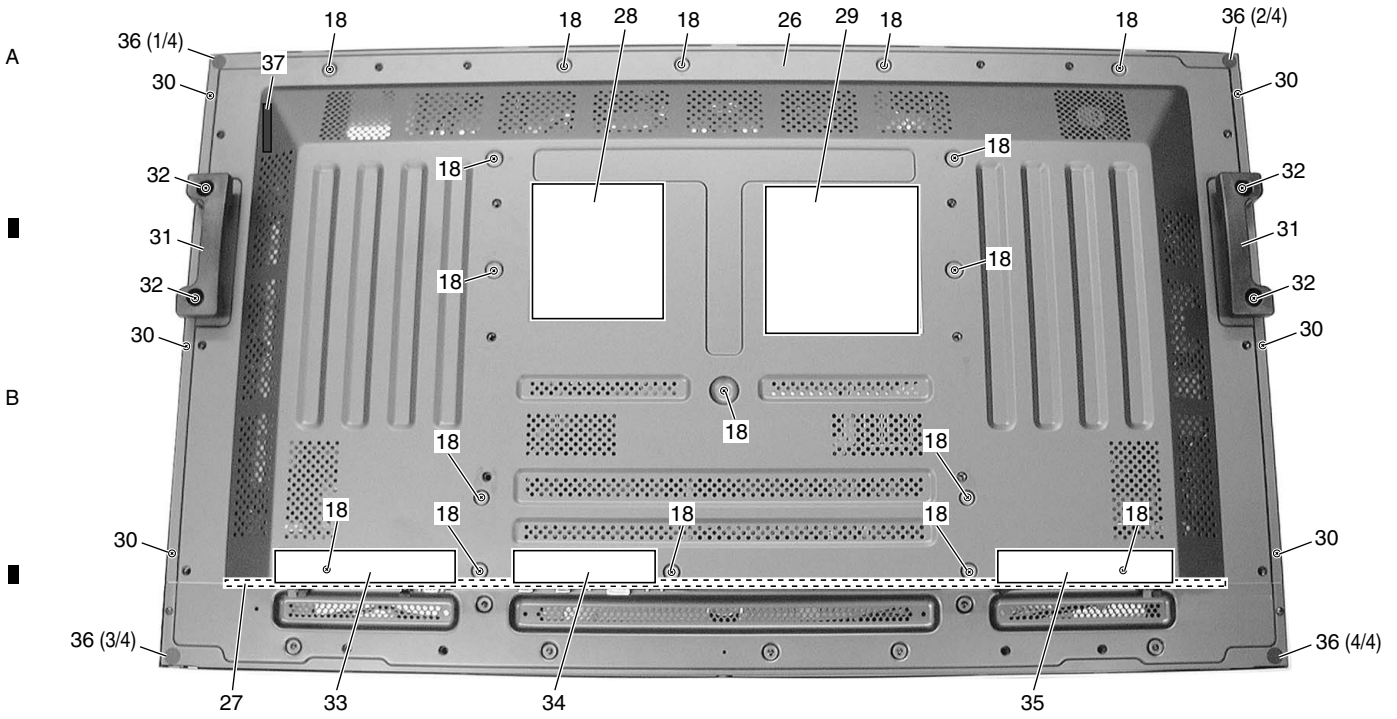

1

2

3

4

TERMINAL PANEL and REAR SECTION parts List

<u>Mark No.</u>	<u>Description</u>	<u>Part No.</u>	
1	COMM SLOT I/F Assy	AWZ6980	
2	COMM SLOT Assy	AWZ6849	
⚠ 3	AC Inlet (CN1)	AKP1255	A
4	SP TERMINAL R Assy	AWZ6857	
5	SP TERMINAL L Assy	AWZ6856	
6	Guide Rail EX	AEC1994	
7	6P Housing Wire (J108)	ADX2889	
8	Wire Saddle	AEC1745	
9	Clamp	AEC1884	
10	Terminal Panel (504CMX)	ANG2603	
11	Gasket SP-T	ANK1750	B
12	Slot Panel 262 (N)	ANG2610	
13	Slot Spring B126	ABK1033	
14	Slot Spring T130	ABK1032	
15	Slot Spring T94	ABK1034	
16	Slot Spring B92	ABK1035	
17	Screw	VBB30P080FNI	
18	Screw	AMZ30P060FTB	
19	Nut	ABN1040	
20	Hexagon Head Screw	BBA1051	
⚠ 21	Power Switch (S1)	ASG1094	C
22	Housing Wire (MX)(J116)	ADX2896	
23	COMM Stay A	ANG2605	
24	COMM Stay B	ANG2606	
25	Screw	APZ30P060FTB	
26	Rear Case (50M)	ANE1623	
27	Gasket T-R50	ANK1751	
NSP 28	Name Label	AAL2516	
29	Caution Label	AAX3048	
30	Screw	TBZ40P080FTB	D
31	Grip	AMR3380	
32	Screw	HMB50P140FTB	
33	Terminal Label R (50M2)	AAX3063	
34	Terminal Label C (M)	AAX3064	
35	Terminal Label L	AAX3061	
36	Rear Corner Label (15)	AAX3081	
37	Serial Sheet	AAX3143	E

1 2 3 4

2.2.5 FRONT SECTION

A

B

C

D

E

F

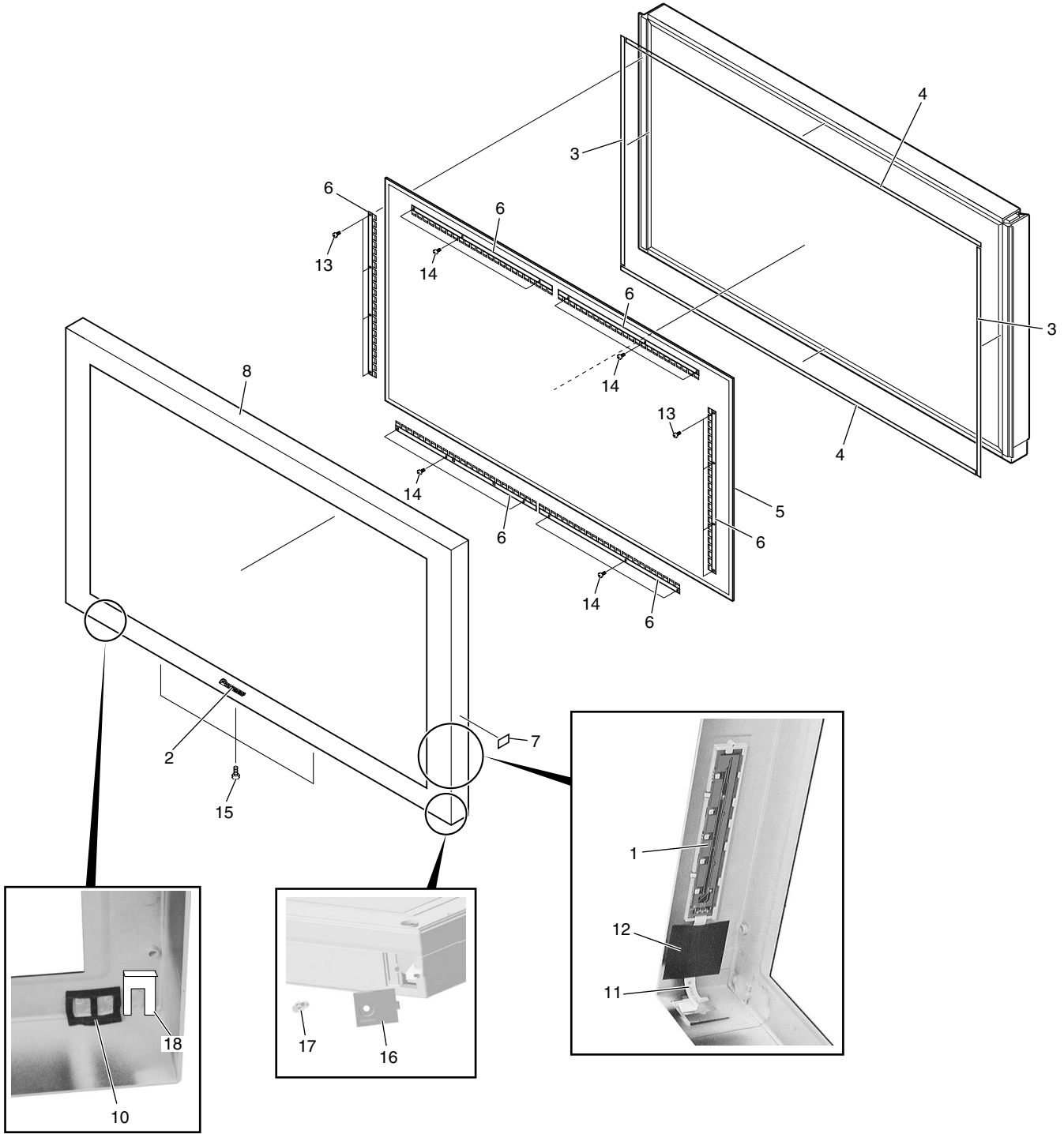

FRONT SECTION parts List

<u>Mark No.</u>	<u>Description</u>	<u>Part No.</u>
1	SIDE KEY Assy	AWZ6852
2	PIONEER Badge	AAM1101
3	Panel Cushion V	AED1269
4	Panel Cushion H	AED1270
 5	Protect Panel Assy (50)	AMR3348
NSP 6	Panel Holder (50)	ANG2563
7	Display Label	AAX2836
8	Front Case	AMB2788
9	•••••	
10	Blind Cushion	AEB1400
11	Flexible Cable (J211)	ADD1265
12	Flexible Seal	AEH1074
13	Screw	ABZ30P060FTC
14	Screw	APZ30P080FTB
15	Screw	APZ30P120FTB
16	Lead Cover	AMR3394
17	Rivet	AEC1877
18	Earth Plate (MX)	AMR3432

A
B
C
D
E
F

2.2.6 PANEL CHASSIS (50) ASSY (AWU1111)

Panel Chassis (50) Assy (AWU1111)

• Parts List

A	Mark No.	Description	Part No.
	NSP	1..50 ADDRESS Assy	AWV2080
	NSP	2..50 ADDRESS Assy	AWZ6870
	NSP	1..50 SCAN FUKUGO Assy	AWV2083
	NSP	2..50 SCAN A Assy	AWZ6878
	NSP	2..50 SCAN B Assy	AWZ6879
	NSP	2..X CONNECTOR A Assy	AWZ6880
	NSP	2..X CONNECTOR B Assy	AWZ6881
	NSP	Address Module (IC1-IC40)	AXF1129
B	NSP	Plasma Panel Assy (50")(V1)	AAV1249
	NSP	FPC (50XGA-X)	ADY1084
	NSP	FPC (50XGA-Y)	ADY1085
	NSP	Chassis Assy (50)	ANA1803
		Edge Card Spacer	AEC1998
		PCB Spacer	AEC1944
		PCB Support	AEC1958
		Rivet	AMR1066
		FC Spacer	AMR3370
C	NSP	Adhesive	ZBA-KE3424S
	NSP	Cleaner	ZLX-AP7
	NSP	Tape	ZTA-8101-12
	NSP	Double Faced Tape	ZTB-5015-18
	NSP	Tape	ZTC-POLYCA-11
	NSP	Tape	ZTC-POLYCA-20
	NSP	Tape	ZTB-5015-9
	NSP	Tape	ZTC-900UL-15
	NSP	Silicon Rubber	ZTX-HC20-15
D	NSP	Wiping Cloth	ZTX-MX100-13
	NSP	Film	ZTX-2102Y35-2R5
	NSP	Film	ZTX-2102Y45-2R5
	NSP	Film	ZTX-2102Y45-5
	NSP	Silicon Rubber	ZTX-HC50-15
	NSP	Silicon Rubber	ZTC-EM7KBOR85T-15W

E

F

2.2.7 PDP SERVICE ASSY (AWU1114)
PDP SERVICE Assy (AWU1114)

• Parts List

Mark No.	Description	Part No.	
NSP	P. Chassis (50) Assy	AWU1111	A
NSP	Front Chassis H (50)	ANA1733	
	F. Chassis VL (50M)	ANA1753	
	F. Chassis VR (50M)	ANA1754	
	Sub Frame L Assy (50M)	ANG2596	
	Sub Frame R Assy (50M)	ANG2598	
	Rear Frame (50M)	ANG2602	
NSP	SVC.Terminal P504CMX	ANG2680	
	Wire Saddle	AEC1745	B
	PCB Support	AEC1938	
	PCB Spacer	AEC1941	
	PCB Spacer	AEC1947	
	Wire Clip	AEC1948	
	Panel Cushion V	AED1269	
	Panel Cushion H	AED1270	
	Front Spacer (CMX)	AMR3384	
	Wire Clip	AEC1992	
	Enclosure Sheet 1	AMR3405	
	Enclosure Sheet 2 (V)	AMR3411	C
	Caution Label	AAX3031	
NSP	Drive Voltage Label	ARW1097	
	Screw	ABZ30P060FTC	
	Screw	AMZ30P060FTB	
	Screw	AMZ30P080FTC	
	Screw	BPZ30P080FTB	
	Screw	APZ30P120FTB	
	Screw	TBZ40P080FTB	D
	Screw	PMB30P060FNI	
NSP	Front Case (504CMX SVC)	AMB2839	
	Rear Case (50M)	ANE1623	
	Pad	AHA2280	
	Under Carton	AHD3037	
NSP	Upper Carton 504CMX S	AHD3256	
	Protect Sheet	AHG1331	
	SCAN Heatsink	ANH1630	
	Sel Plate	ANG2712	E
	Card Spacer	AEC2013	
	SCAN Silicon Sheet	AEH1080	
	Gasket (CM)	ANK1748	
	Rear Corner Label (15)	AAX3081	

2.3 PDP-434CMX model

2.3.1 CHASSIS SECTION (1)

A

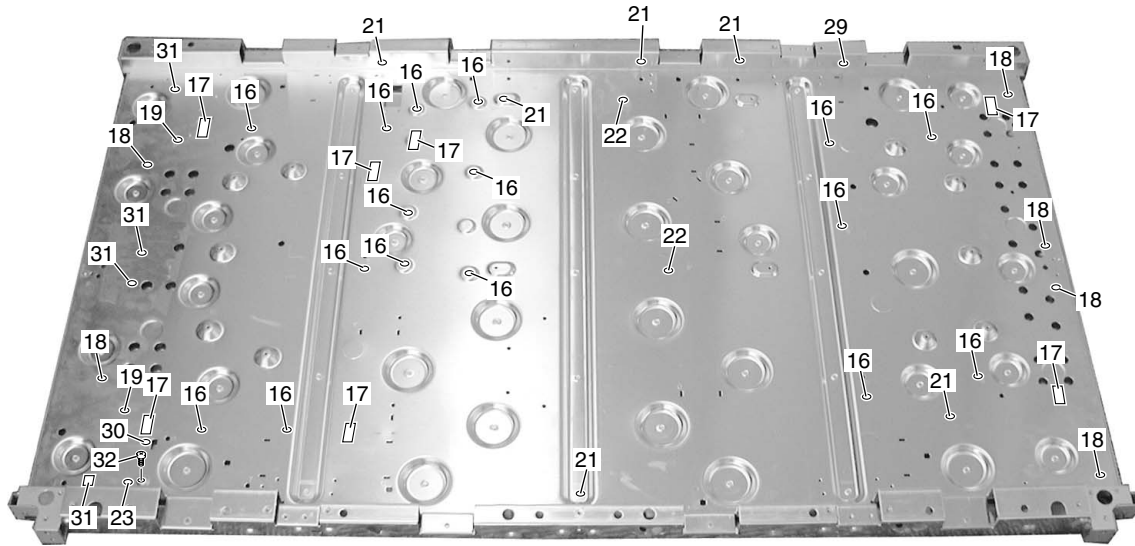

B

C

D

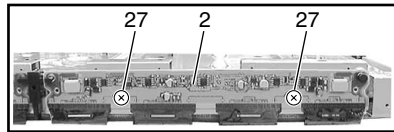

E

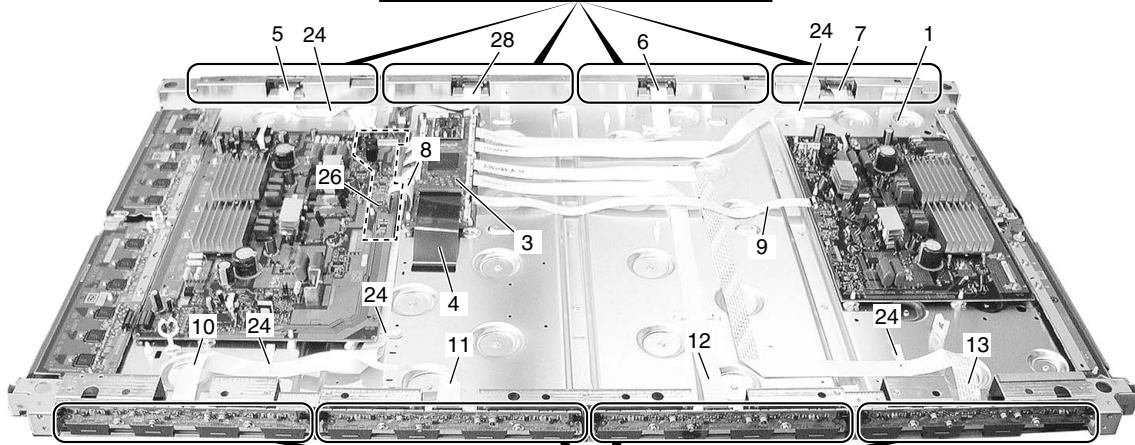

F

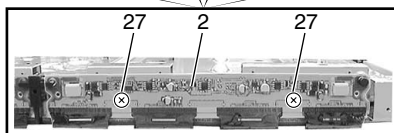

CHASSIS SECTION (1) parts List

<u>Mark No.</u>	<u>Description</u>	<u>Part No.</u>	
NSP 1	P. Chassis (43) Assy	AWU1112	
NSP 2	43 ADDRESS Assy	AWZ6862	A
3	DIGITAL VIDEO Assy	AWV2169	
4	FPC (114P)	ADY1081	
5	Flexible Cable (J201)	ADD1257	
6	Flexible Cable (J203)	ADD1259	
7	Flexible Cable (J204)	ADD1260	
8	Flexible Cable (J209)	ADD1223	
9	Flexible Cable (J210)	ADD1224	
10	Flexible Cable (J205)	ADD1261	
11	Flexible Cable (J206)	ADD1262	B
12	Flexible Cable (J207)	ADD1263	
13	Flexible Cable (J208)	ADD1282	
14	•••••		
15	•••••		
16	PCB Spacer	AEC1941	
17	PCB Support	AEC1938	
18	PCB Spacer	AEC1944	
19	PCB Support	AEC1958	
20	•••••		C
21	Wire Saddle	AEC1745	
22	PCB Spacer	AEC1947	
23	Wire Clip	AEC1948	
24	Flat Clamp	AEC1879	
25	•••••		
26	Y Drive Protect Sheet	AMR3346	
27	Screw	VBB30P080FNI	
28	Flexible Cable (J202)	ADD1258	
29	Wire Clip	AEC1992	
30	HL 18	AEC1980	D
31	Edge Card Spacer	AEC1998	
32	Screw	ABZ30P060FTC	

2.3.2 CHASSIS SECTION (2)

1

2

3

4

A

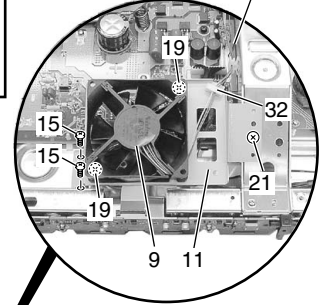
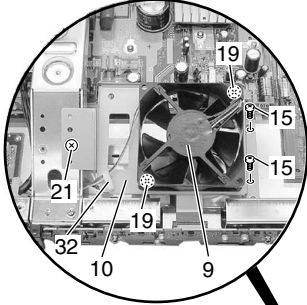
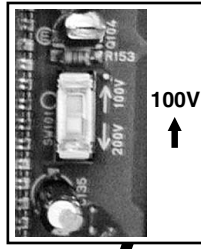
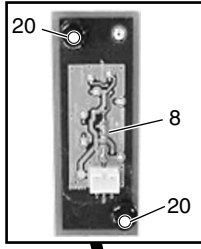

B

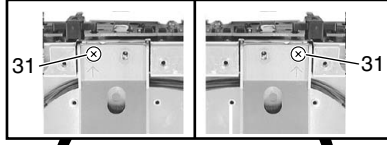

Upper side

Upper side

C

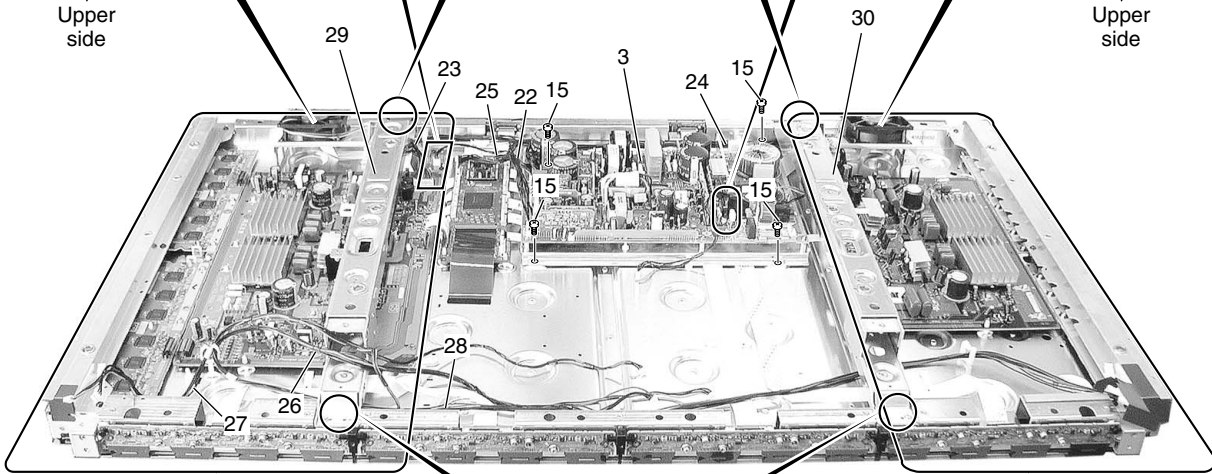

D



E

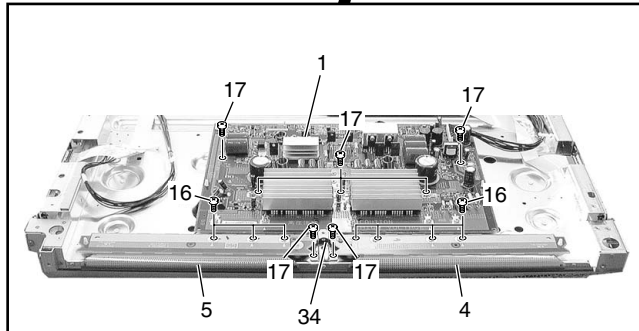
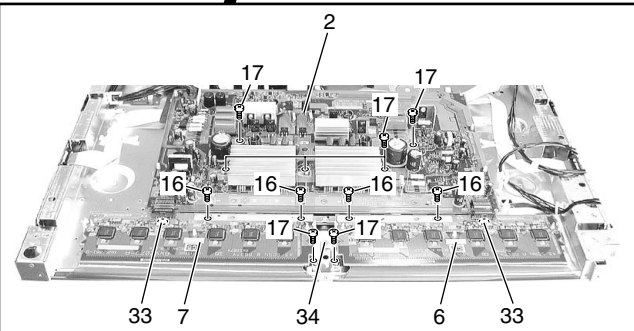

F

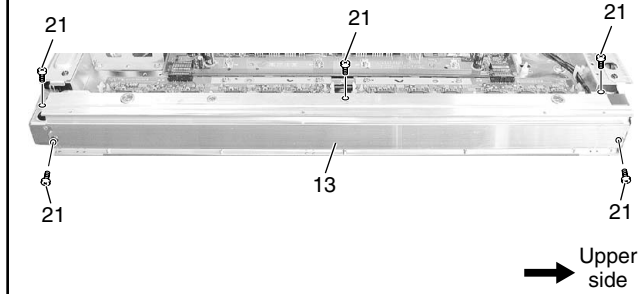
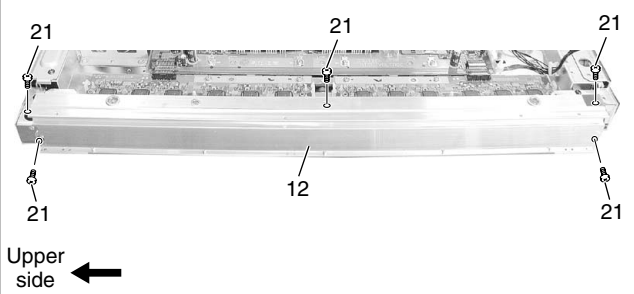

Upper side ←

→ Upper side

1

2

3

4

CHASSIS SECTION (2) parts List

Mark No.	Description	Part No.	
1	43 X DRIVE Assy	AWZ6865	
2	43 Y DRIVE Assy	AWV2078	A
⚠ 3	POWER SUPPLY Unit	AXY1083	
NSP 4	X CONNECTOR B Assy	AWZ6876	
NSP 5	X CONNECTOR A Assy	AWZ6875	
NSP 6	43 SCAN A Assy	AWZ6873	
NSP 7	43 SCAN B Assy	AWZ6874	
8	PANEL SENSOR Assy	AWZ6872	
9	Fan Motor (80 x 25)	AXM1044	
10	Fan Angle L (43M)	ANG2655	
11	Fan Angle R (43M)	ANG2656	B
12	F. Chassis VL (43M)	ANA1755	
13	F. Chassis VR (43M)	ANA1756	
14	Housing Wire (J117)	ADX2904	
15	Screw	ABZ30P060FTC	
16	Screw	PMB30P060FNI	
17	Screw	VBB30P080FNI	
18	•••••		
19	Screw	PPZ50P100FTB	
20	Nylon Rivet	AEC1671	C
21	Screw	AMZ30P060FTB	
22	3P Housing Wire (J109)	ADX2847	
23	11P Housing Wire (J102)	ADX2840	
24	12P Housing Wire (J103)	ADX2841	
25	Wire A (J101)	ADX2839	
26	Wire G (J118)	ADX2905	
27	Wire F (J119)	ADX2906	
28	9P Housing Wire (J115)	ADX2902	
29	SUB Frame L Assy (43M)	ANG2623	
30	SUB Frame R Assy (43M)	ANG2625	D
31	Screw	AMZ30P080FTC	
32	Wire Clip	AEC1948	
NSP 33	Card Spacer	AEC2013	
34	SeI Plate	ANG2712	

2.3.3 FRAME SECTION

A

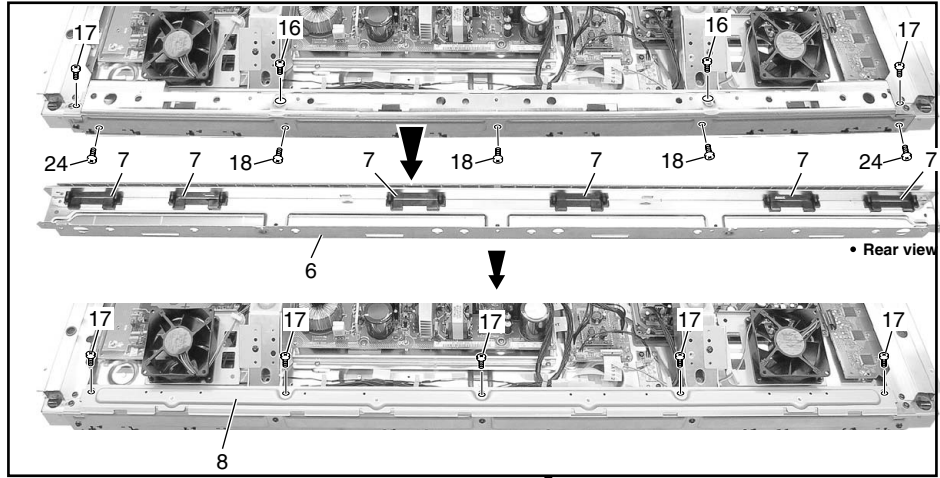

C

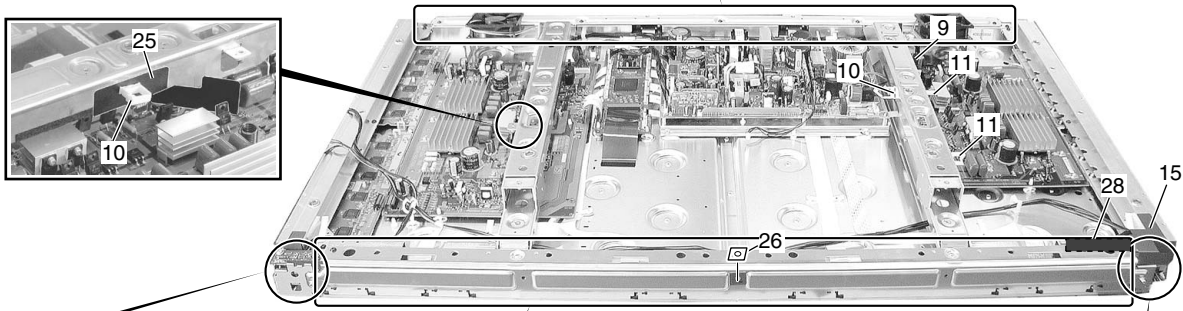

D

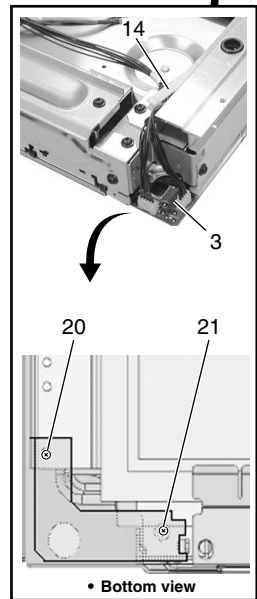
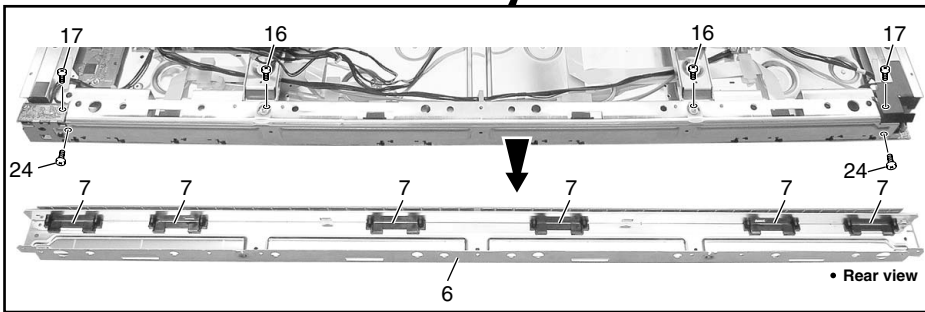

E

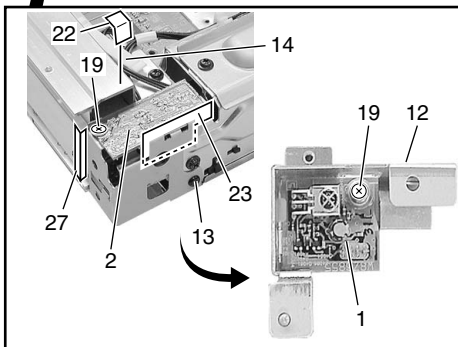

F

FRAME SECTION parts List

<u>Mark No.</u>	<u>Description</u>	<u>Part No.</u>	
1	IR RECEIVE Assy	AWZ6989	
2	KEY CONTROL Assy	AWZ6981	A
3	LED OPT Assy	AWZ6967	
4	•••••		
5	•••••		
NSP 6	Front Chassis H (43)	ANA1714	
7	Front Spacer (CMX)	AMR3384	
8	Rear Frame (43M)	ANG2613	
9	Wire Clip	AEC1948	
10	Wire Clip	AEC1992	
11	Wire Saddle	AEC1745	B
NSP 12	IR Holder	ANG2551	
13	Nylon Rivet	AEC1671	
14	Flat Clamp	AEC1879	
15	Enclosure Sheet 1	AMR3405	
16	Screw	AMZ30P080FTC	
17	Screw	AMZ30P060FTB	
18	Screw	BPZ30P080FTB	
19	Screw	ABZ30P060FTC	
20	Nylon Rivet	AEC1997	C
21	Screw	BBZ30P050FTC	
22	Enclosure Sheet 2 (V)	AMR3411	
23	Enclosure Sheet 3	AMR3407	
24	Screw	PMB30P060FNI	
25	Cable Gard	AMR3439	
NSP 26	Front Case Spacer	AMR3430	
27	Gasket FC-IR	ANK1758	
28	Gasket FC-T	ANK1757	D

2.3.4 TERMINAL PANEL and REAR SECTION

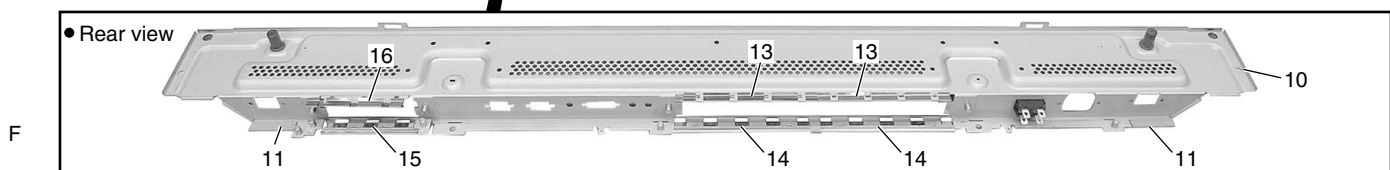
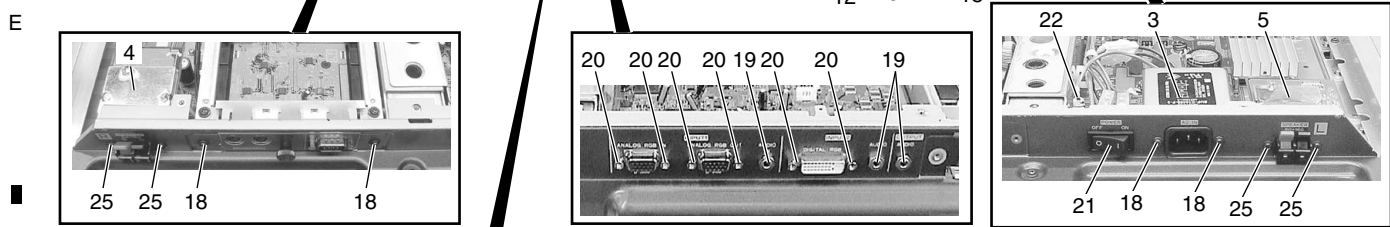
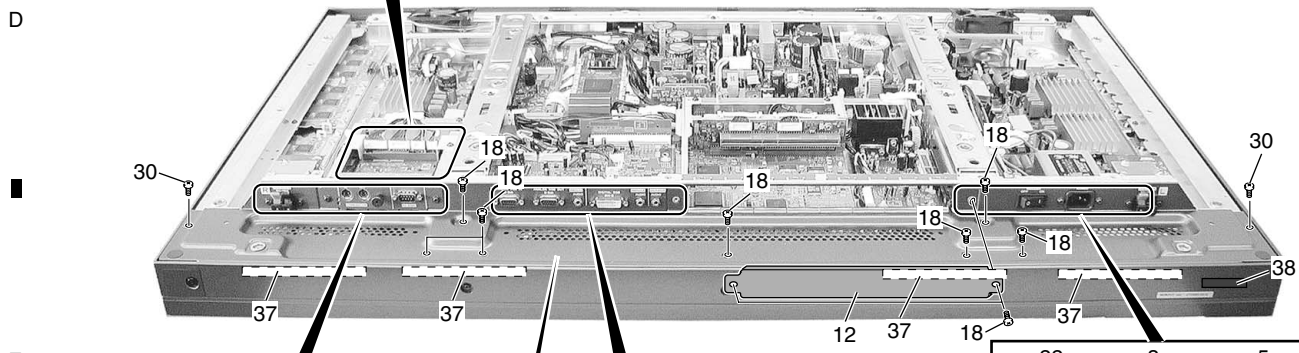
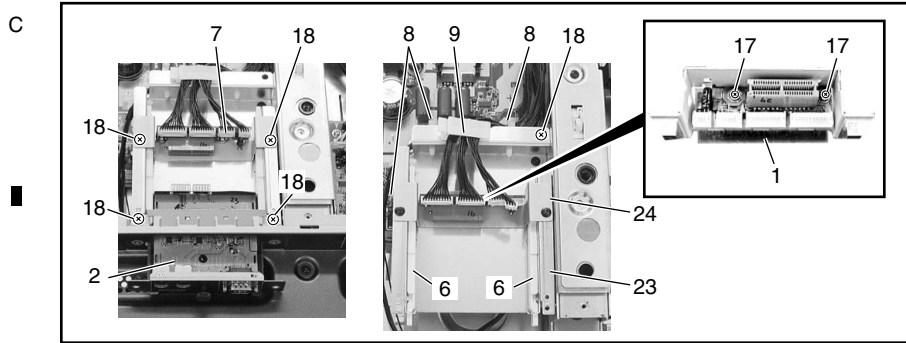
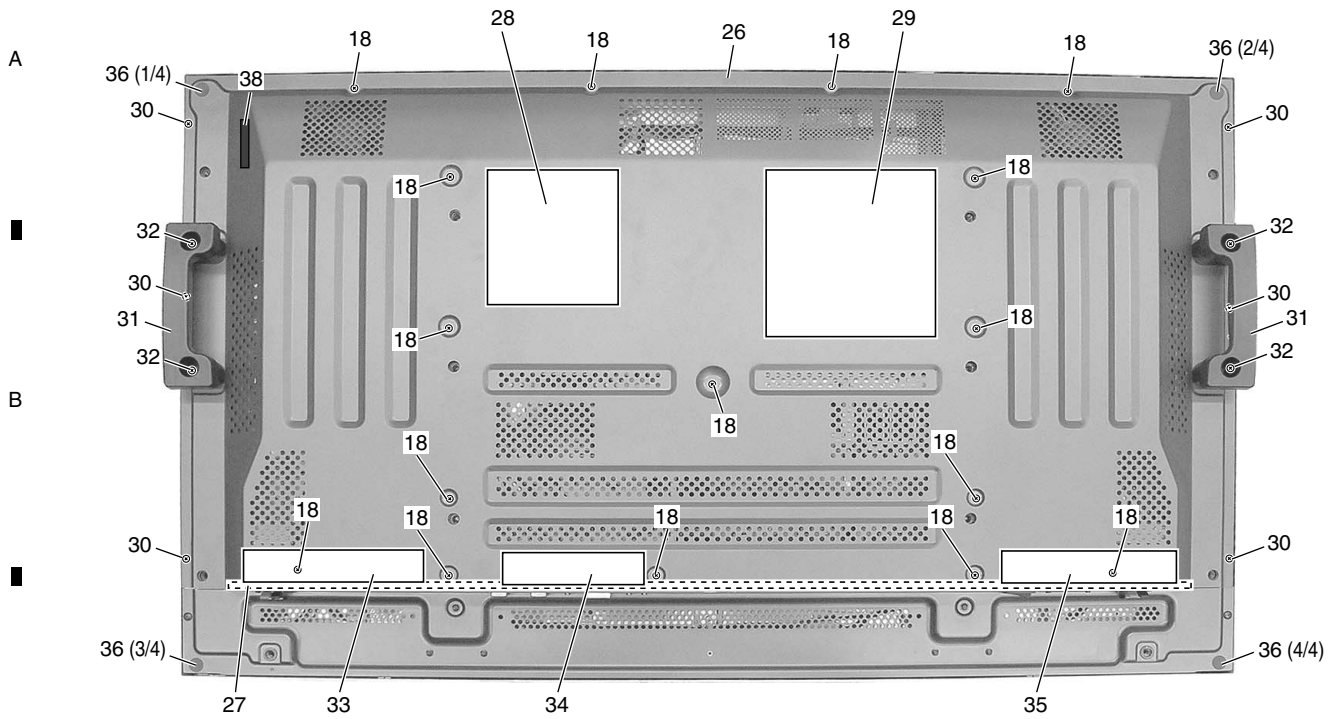

TERMINAL PANEL and REAR SECTION parts List

<u>Mark No.</u>	<u>Description</u>	<u>Part No.</u>	
1	COMM SLOT I/F Assy	AWZ6980	
2	COMM SLOT Assy	AWZ6849	A
⚠ 3	AC Inlet (CN1)	AKP1244	
4	SP TERMINAL R Assy	AWZ6857	
5	SP TERMINAL L Assy	AWZ6856	
6	Guide Rail EX	AEC1994	
7	6P Housing Wire (J108)	ADX2911	
8	Wire Saddle	AEC1745	
9	Clamp	AEC1884	
10	Terminal Panel (43M)	ANG2733	
11	Gasket SP-T	ANK1750	B
12	Slot Panel 262 (N)	ANG2610	
13	Slot Spring B126	ABK1033	
14	Slot Spring T130	ABK1032	
15	Slot Spring T94	ABK1034	
16	Slot Spring B92	ABK1035	
17	Screw	VBB30P080FNI	
18	Screw	AMZ30P060FTB	
19	Nut	ABN1040	
20	Hexagon Head Screw	BBA1051	C
⚠ 21	Power Switch (S1)	ASG1094	
22	Housing Wire (MX)(J116)	ADX2896	
23	COMM Stay A	ANG2605	
24	COMM Stay B	ANG2606	
25	Screw	APZ30P060FTB	
26	Rear Case (43M)	ANE1624	
27	Gasket T-R43	ANK1754	
NSP 28	Name Label (434CMX)	AAL2529	
29	Caution Label	AAX3048	D
30	Screw	TBZ40P080FTB	
31	Grip	AMR3380	
32	Screw	HMB50P140FTB	
33	Terminal Label R (50M2)	AAX3050	
34	Terminal Label C (M)	AAX3064	
35	Terminal Label L	AAX3062	
36	Rear Corner Label (15)	AAX3081	
37	Spacer	AMR3433	
38	Serial Sheet	AAX3143	E

1 2 3 4

2.3.5 FRONT SECTION

A

B

C

D

E

F

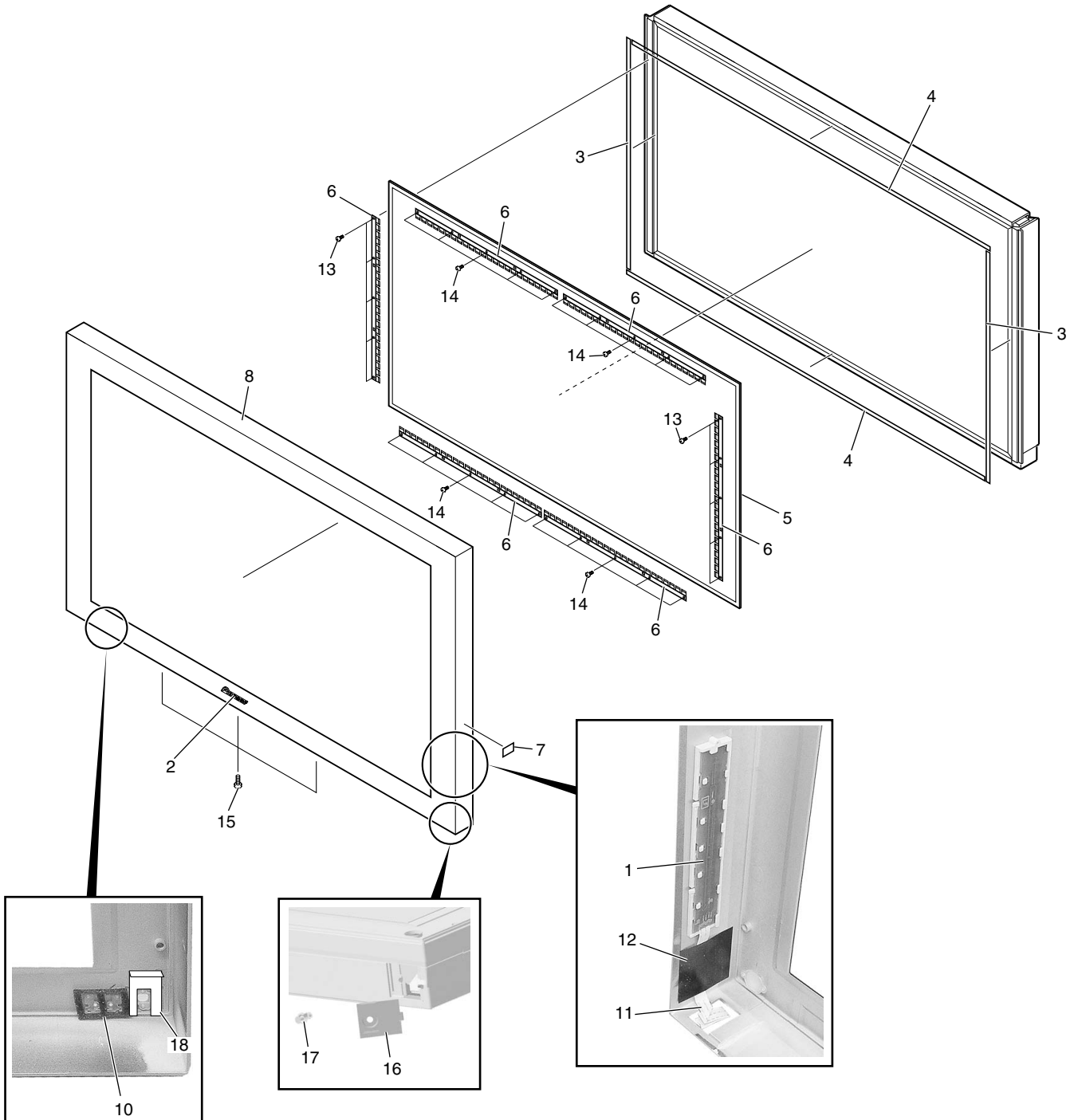

FRONT SECTION parts List

<u>Mark No.</u>	<u>Description</u>	<u>Part No.</u>
1	SIDE KEY Assy	AWZ6852
2	PIONEER Badge	AAM1101
3	Panel Cushion V (43)	AED1254
4	Panel Cushion H (43)	AED1253
△ 5	Protect Panel Assy (43)	AMR3345
NSP 6	Panel Holder (43)	ANG2552
7	Display Label	AAX2836
8	Front Case 434 (CMX)	AMB2790
9	•••••	
10	Blind Cushion	AEB1400
11	Flexible Cable (J211)	ADD1265
12	Flexible Seal	AEH1074
13	Screw	ABZ30P060FTC
14	Screw	APZ30P080FTB
15	Screw	APZ30P120FTB
16	Lead Cover	AMR3394
17	Rivet	AEC1877
18	Earth Plate (MX)	AMR3432

A
B
C
D
E
F

2.3.6 PANEL CHASSIS (43) ASSY (AWU1112)

Panel Chassis (43) Assy (AWU1112)

• Parts List

A	Mark No.	Description	Part No.
	NSP	1..43 ADDRESS Assy	AWV2076
	NSP	2..43 ADDRESS Assy	AWZ6862
	NSP	1..43 SCAN FUKUGO Assy	AWV2079
	NSP	2..43 SCAN A Assy	AWZ6873
	NSP	2..43 SCAN B Assy	AWZ6874
	NSP	2..X CONNECTOR A Assy	AWZ6875
	NSP	2..X CONNECTOR B Assy	AWZ6876
	NSP	Address Module (IC1-IC30)	AXF1126
B	NSP	Plasma Panel Assy (43")(V1)	AAV1248
	NSP	FPC (43XGA-X)	ADY1079
	NSP	FPC (43XGA-Y)	ADY1080
	NSP	Chassis Assy (435)	ANA1802
		Edge Card Spacer	AEC1998
		PCB Spacer	AEC1944
		PCB Support	AEC1958
		Rivet	AMR1066
		FC Spacer	AMR3370
C	NSP	Adhesive	ZBA-KE3424S
	NSP	Cleaner	ZLX-AP7
	NSP	Tape	ZTA-8101-12
	NSP	Double Faced Tape	ZTB-5015-18
	NSP	Tape	ZTC-POLYCA-11
	NSP	Tape	ZTC-POLYCA-20
	NSP	Tape	ZTB-5015-9
	NSP	Tape	ZTC-900UL-15
	NSP	Silicon Rubber	ZTX-HC20-15
D	NSP	Wiping Cloth	ZTX-MX100-13
	NSP	Film	ZTX-2102Y35-2R5
	NSP	Film	ZTX-2102Y45-2R5
	NSP	Film	ZTX-2102Y45-5
	NSP	Silicon Rubber	ZTX-HC50-15
	NSP	Silicon Rubber	ZTC-EM7KBOR85T-15W

E

F

2.3.7 PDP SERVICE ASSY (AWU1115)

PDP SERVICE Assy (AWU1115)

• Parts List

Mark No.	Description	Part No.	
NSP	P. Chassis (43) Assy	AWU1112	A
NSP	Front Chassis H (43)	ANA1714	
	F. Chassis VL (43M)	ANA1755	
	F. Chassis VR (43M)	ANA1756	
	Sub Frame L Assy (43M)	ANG2613	
	Sub Frame R Assy (43M)	ANG2628	
	Rear Frame (43M)	ANG2625	
NSP	SVC.Terminal P434CMX	ANG2701	
	Wire Saddle	AEC1745	
	PCB Support	AEC1938	B
	PCB Spacer	AEC1941	
	PCB Spacer	AEC1947	
	Wire Clip	AEC1948	
	Wire Clip	AEC1992	
	Panel Cushion H (43M)	AED1253	
	Panel Cushion V (43M)	AED1254	
	Front Spacer (CMX)	AMR3384	
	Y Drive Protect Sheet	AMR3346	
	Enclosure Sheet 1	AMR3405	C
	Enclosure Sheet 2 (V)	AMR3411	
	Front Case Spacer	AMR3430	
	Cable Gard	AMR3439	
	Caution Label	AAX3031	
NSP	Drive Voltage Label	ARW1097	
	Screw	ABZ30P060FTC	
	Screw	AMZ30P060FTB	
	Screw	AMZ30P080FTC	
	Screw	BPZ30P080FTB	D
	Screw	APZ30P120FTB	
	Screw	TBZ40P080FTB	
	Screw	VBB30P080FNI	
	Screw	PMB30P060FNI	
NSP	Front Case (434CMX SVC)	AMB2840	
	Rear Case (43M)	ANE1624	
	Pad	AHA2282	
	Pad	AHA2283	E
	Carton	AHD3100	
NSP	Upper Carton 434CMX S	AHD3257	
	Protect Sheet	AHG1331	
	Sel Plate	ANG2712	
	HL18	AEC1980	
	Card Spacer	AEC2013	
	Gasket FC-T	ANK1757	

2.4 MULTI BASE SECTION for PDP-504CMX and PDP-434CMX models

2.4.1 MULTI BASE SECTION

Note : This illustration is 50 inch model.

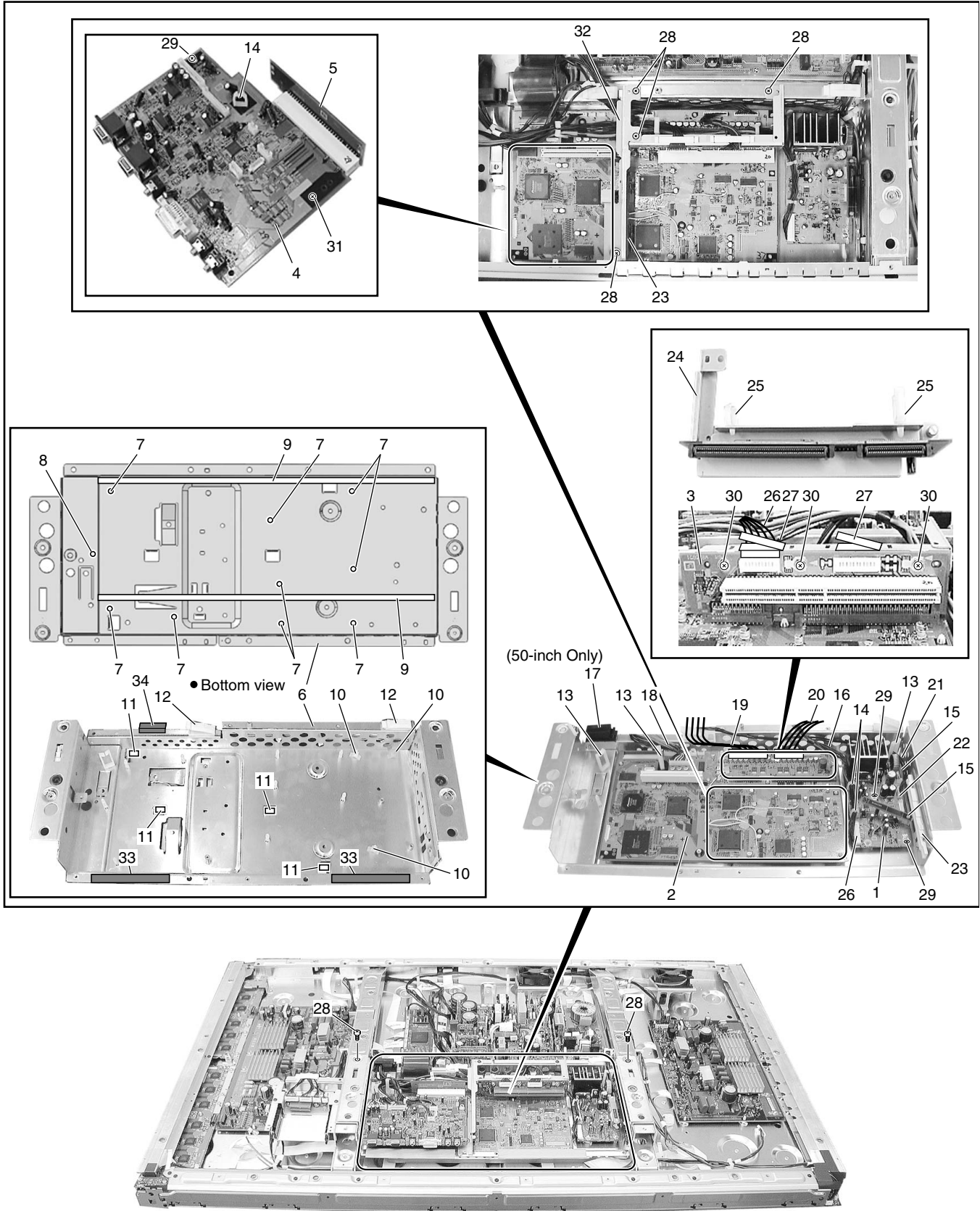

MULTI BASE SECTION parts List

<u>Mark No.</u>	<u>Description</u>	<u>Part No.</u>	<u>Mark No.</u>	<u>Description</u>	<u>Part No.</u>
1	AUDIO AMP Assy	AWZ6848	18	10/11P Housing Wire (J110)	See Contrast table(2)
2	RGB Assy	AWZ6992	19	10P Housing Wire (J113)	ADX2908
3	VIDEO SLOT I/F Assy	AWZ6851	20	12P Housing Wire (J112)	ADX2892
4	AV I/O Assy	See Contrast table(2)			
5	AV I/O I/F Assy	AWZ6859	21	13P/6P Housing Wire (J104)	ADX2910
			22	COVER Assy	AWZ6858
NSP 6	Multi Base (CMX)	ANA1757	23	Guide Rail EX	AEC1994
NSP 7	PCB Holder	AEC1088	24	Slot Stay	ANG2608
8	PCB Spacer	AEC1991	25	Wire Saddle	AEC1745
9	Gasket C-M	ANK1752			
10	Locking Card Spacer	AEC1429	26	11P Housing Wire (J111)	See Contrast table(2)
			27	Flat Clamp	AEC1879
11	Ground Finger	ANG2468	28	Screw	AMZ30P060FTB
12	Clamp	AEC1884	29	Screw	PMB30P060FNI
13	Wire Saddle	AEC1989	30	Screw	VBB30P080FNI
14	Mini Clamp	AEC1971			
15	Double Locking Spacer	AEC1988	31	Pin Grommet	AEC1015
			32	Video Stay	ANG2607
16	15P/16P Housing Wire (J106)	ADX2907	33	Gasket M-T150	See Contrast table(2)
17	Cable Clamp	See Contrast table(2)	34	Shield Sheet	AEC2004

(2) CONTRAST TABLE

PDP-504CMX/LUC/1 and PDP-434CMX/LUC/1 are constructed the same except for the following:

Mark	No.	Symbol and Description	PDP-504CMX/ LUC/1	PDP-434CMX/ LUC/1
	4	AV I/O Assy	AWZ6847	AWZ6894
	17	Cable Clamp	AEC1707	Not used
	18	10/11P Housing Wire (J110)	ADX2890	ADX2912
	26	11P Housing Wire (J111)	ADX2891	ADX2913
	33	Gasket M-T150	ANK1753	ANK1755

3. BLOCK DIAGRAM AND SCHEMATIC DIAGRAM

3.1 BLOCK DIAGRAM

3.1.1 OVERALL BLOCK DIAGRAM (1/2) for PDP-504CMX

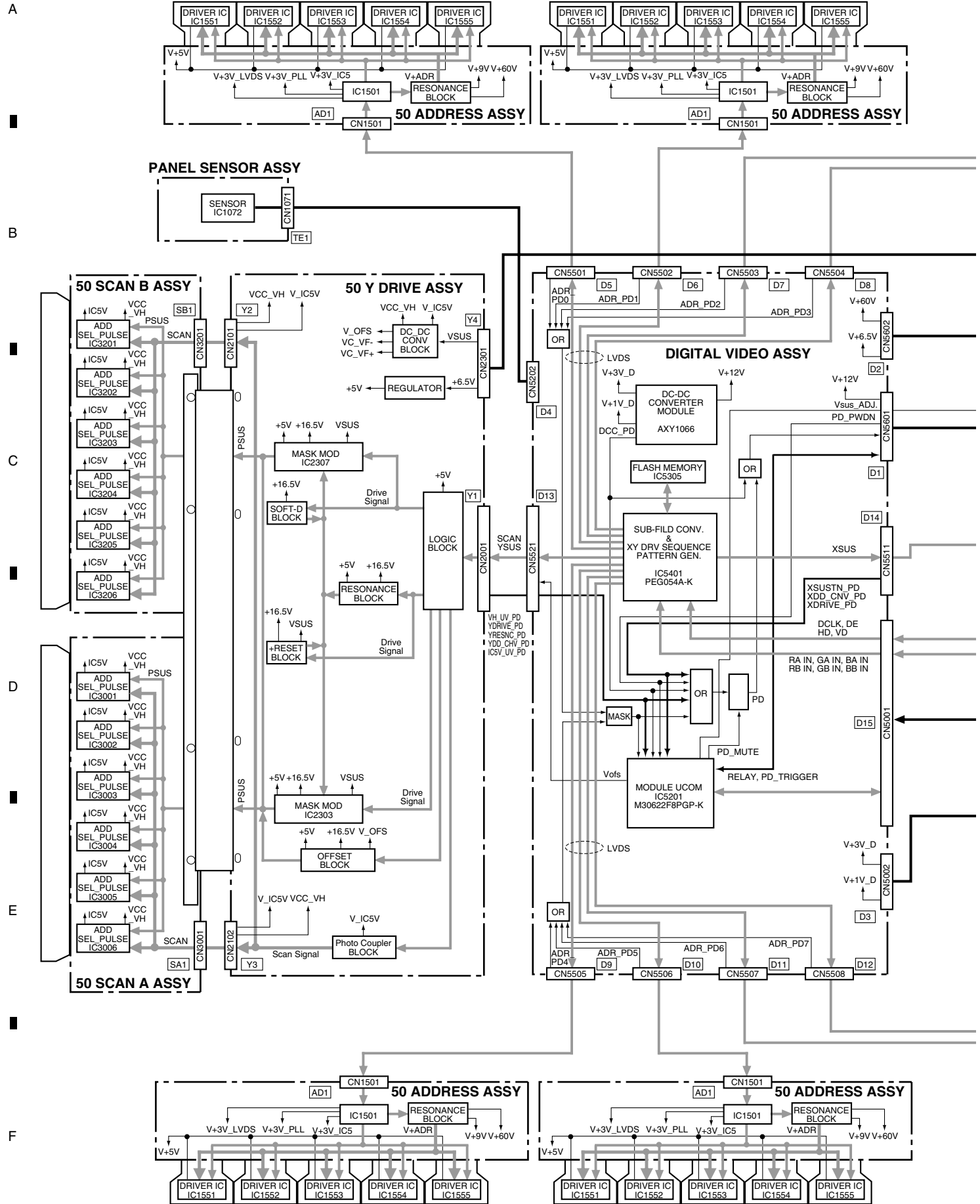

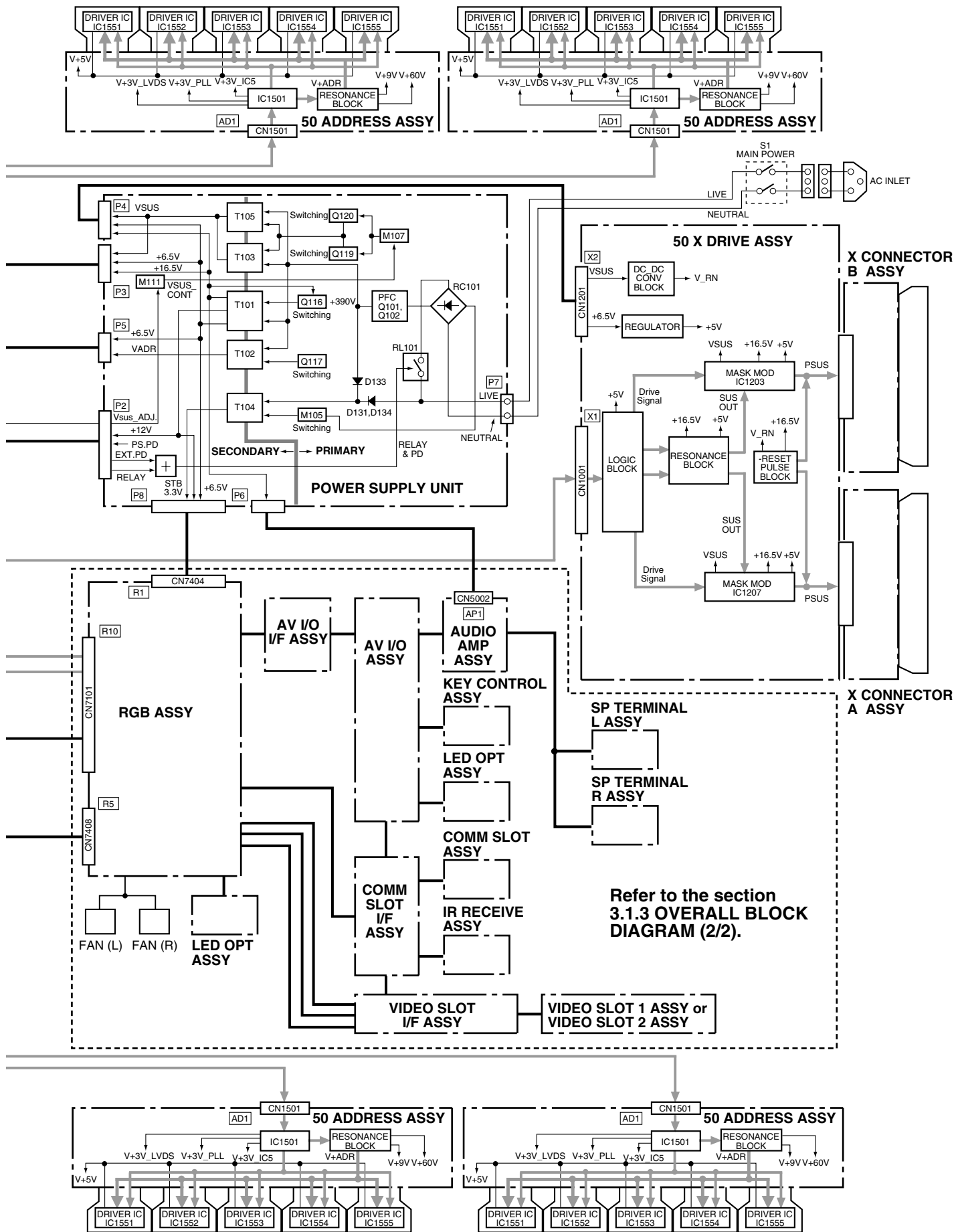

3.1.2 OVERALL BLOCK DIAGRAM (1/2) for PDP-434CMX

A
B
C
D
E
F

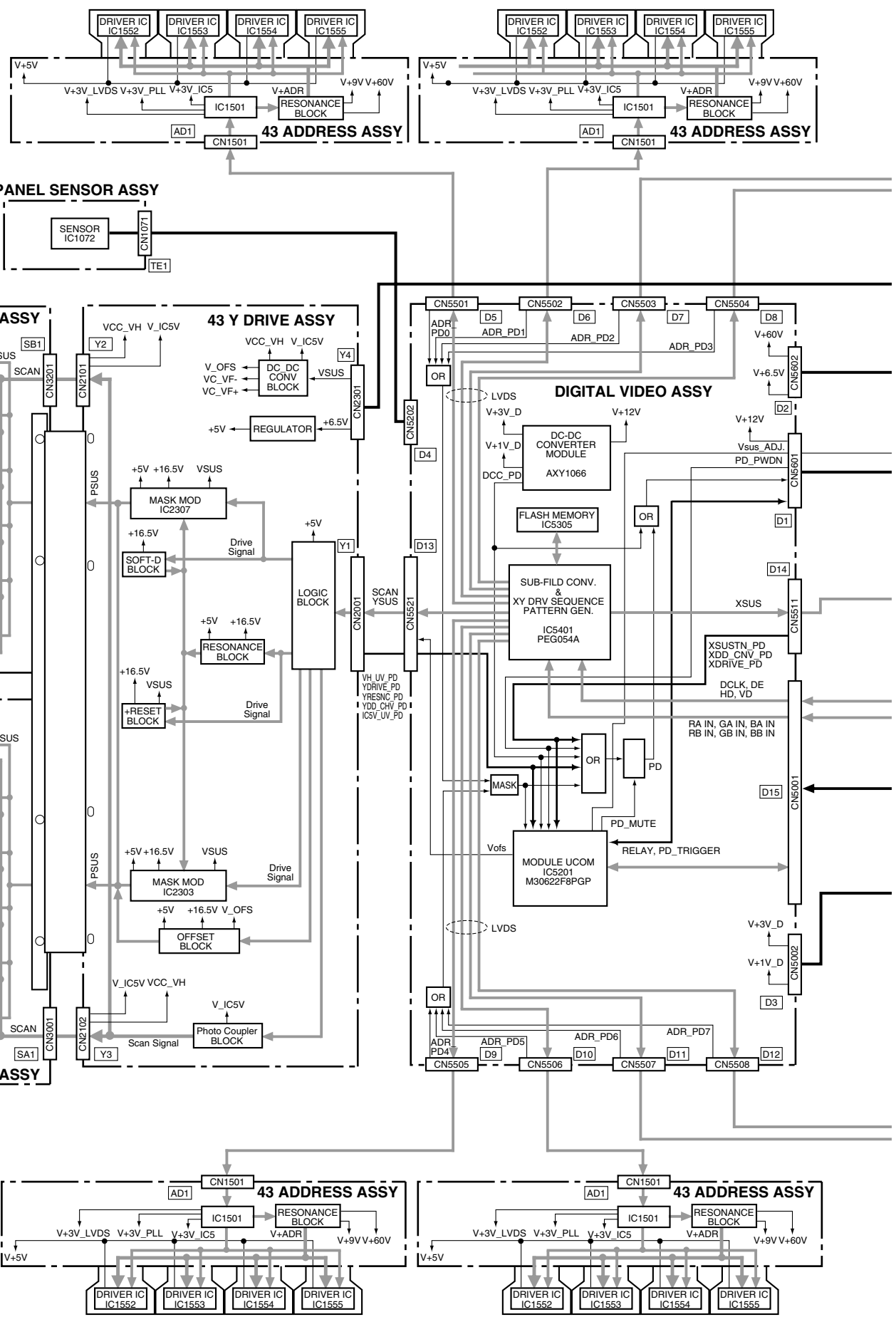

PDP-504CMX/1

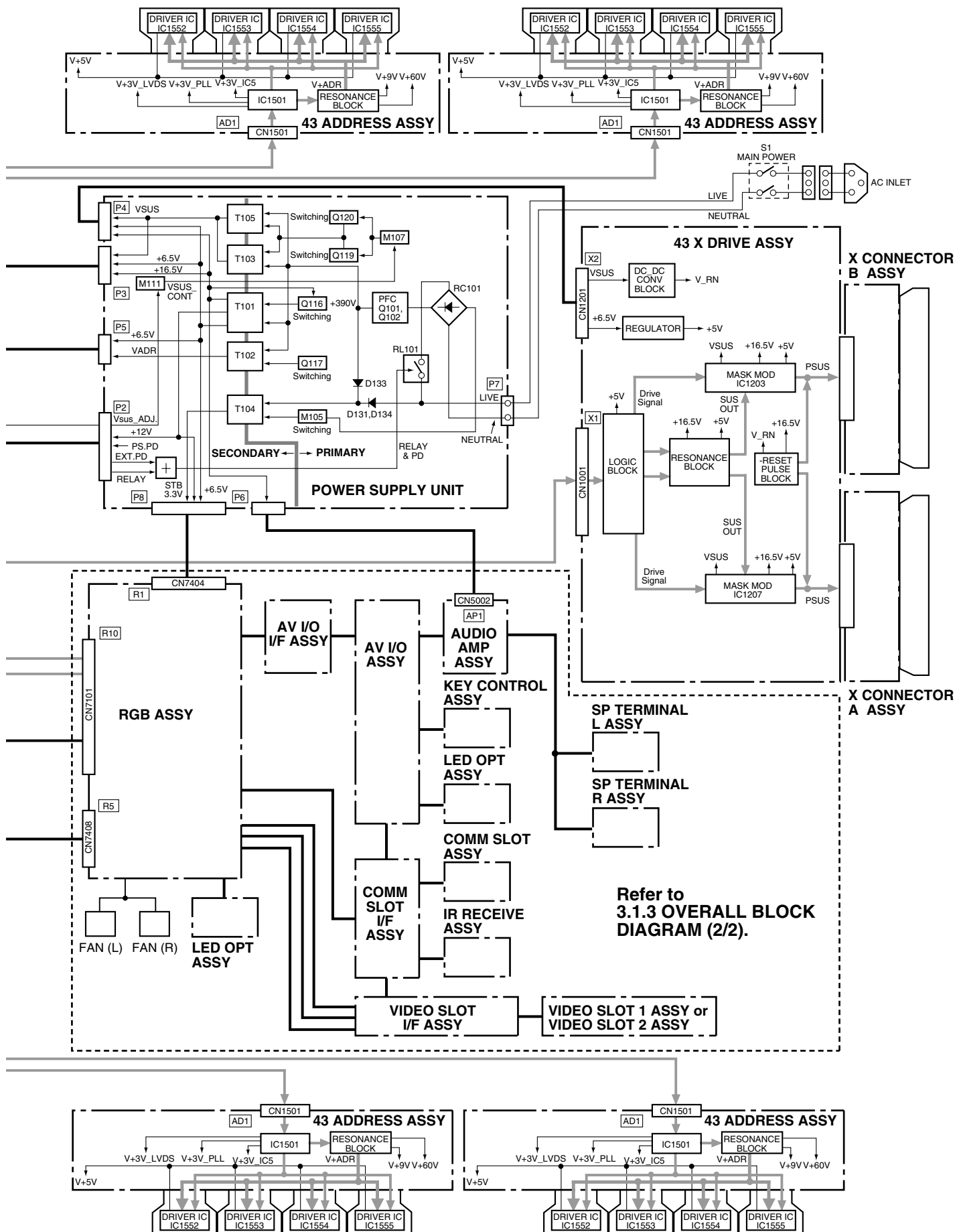

Refer to
3.1.3 OVERALL BLOCK
DIAGRAM (2/2).

3.1.3 OVERALL BLOCK DIAGRAM (2/2)

• Block Diagram

A
B
C
D
E
F

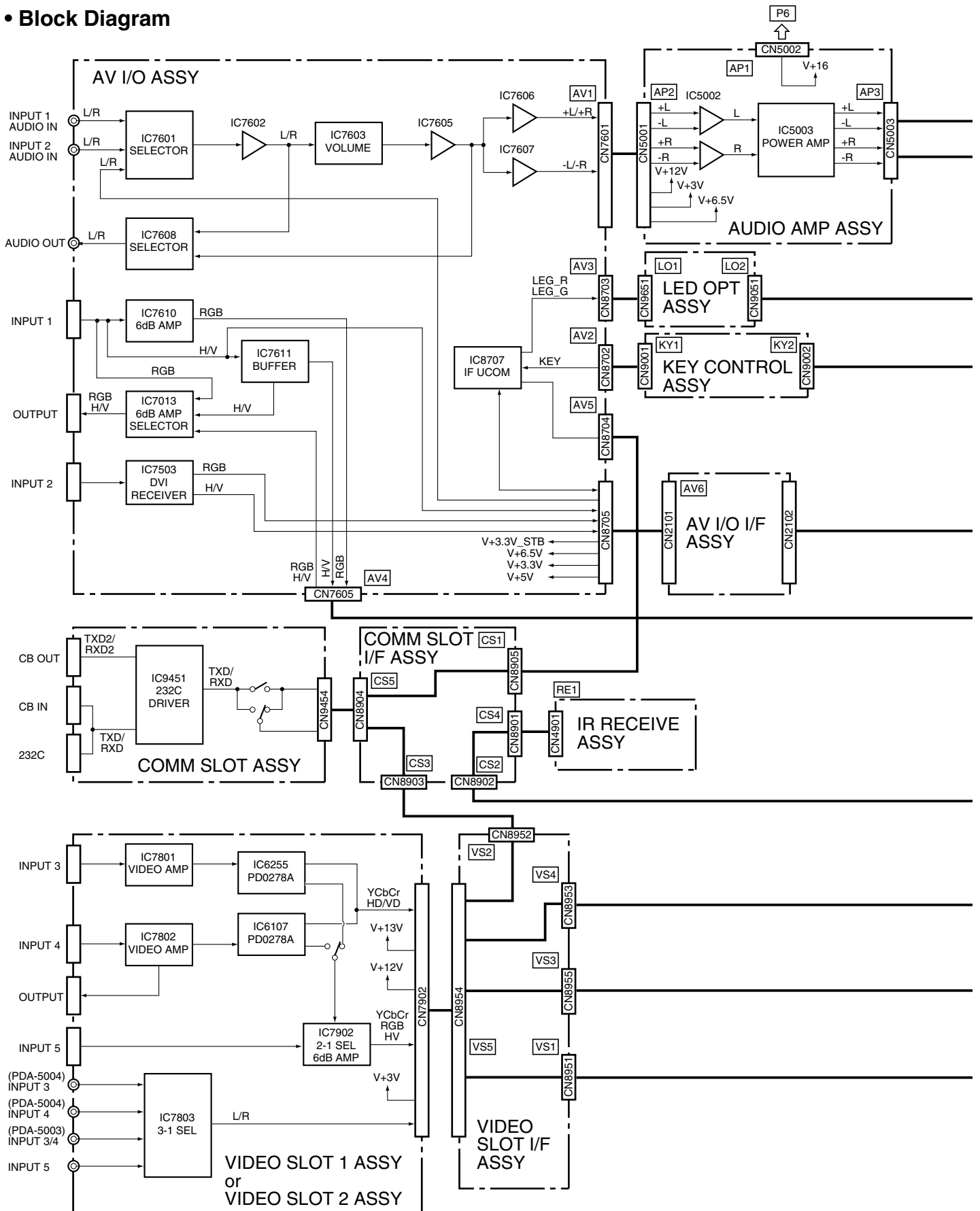

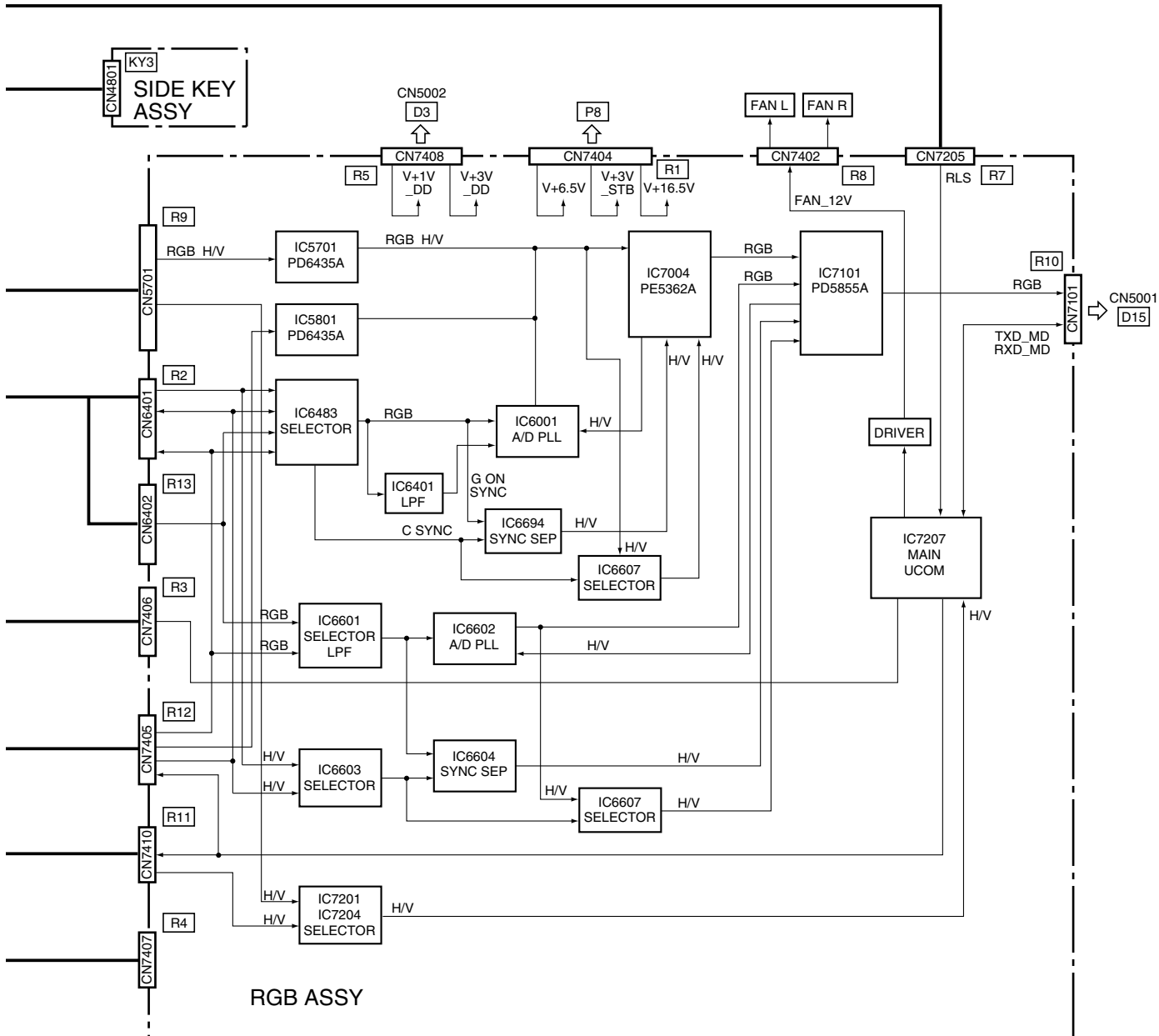
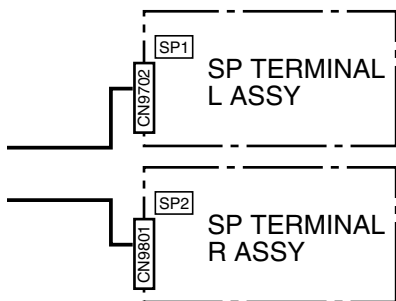

3.1.4 SIGNAL ROUTE

• Block Diagram

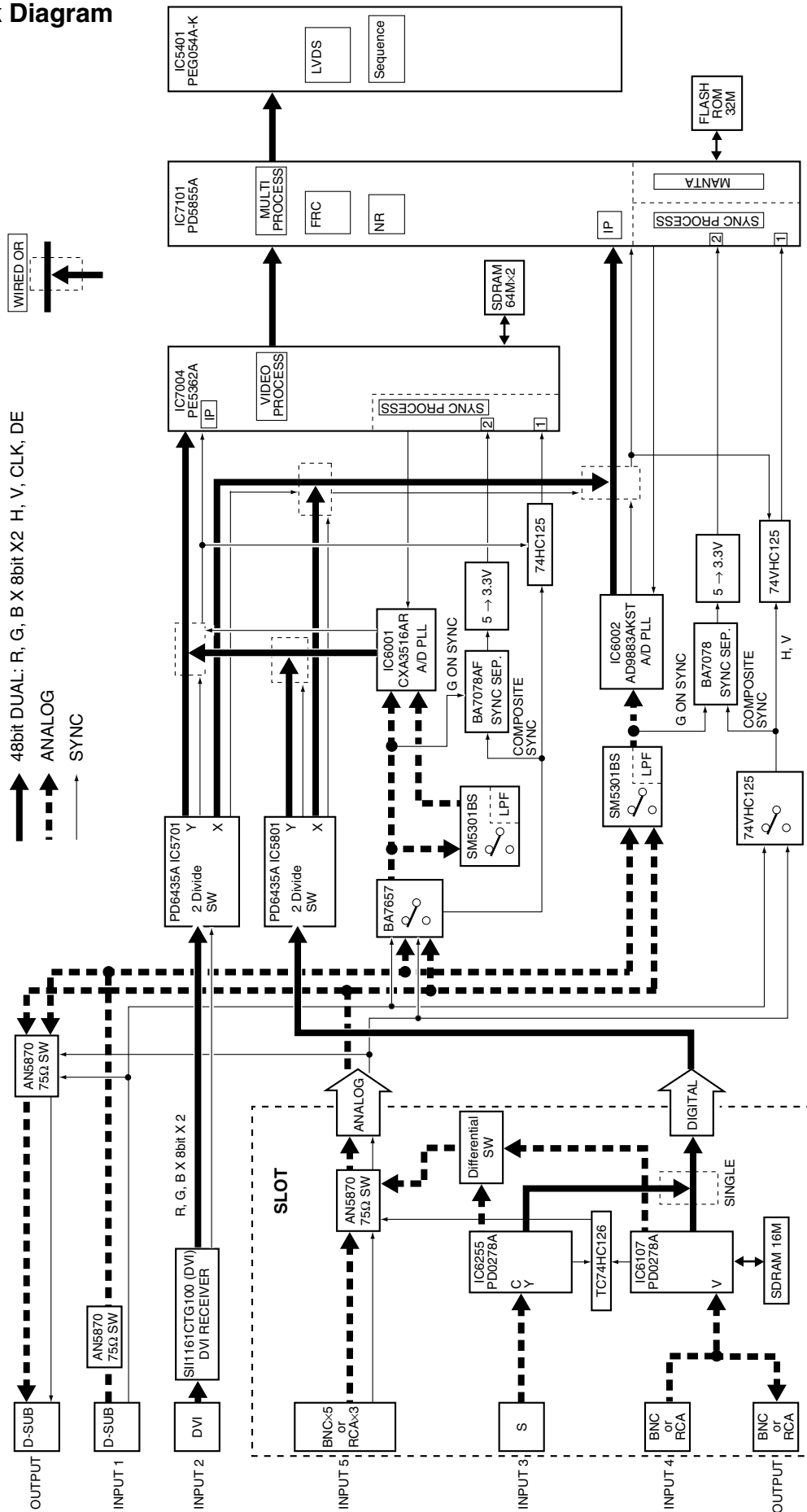

3.1.5 50 Y DRIVE ASSY

• Block Diagram

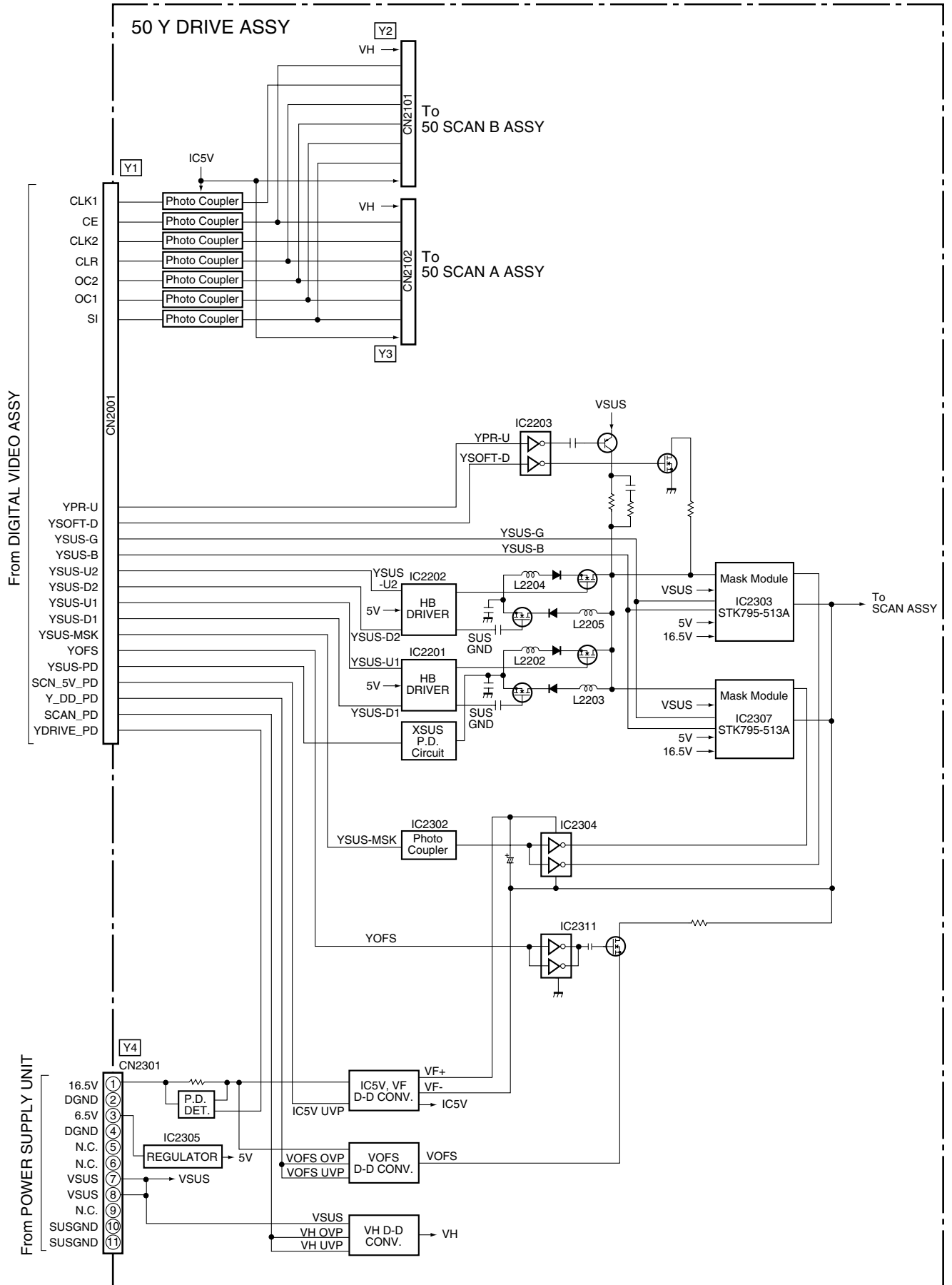

3.1.6 43 Y DRIVE ASSY

• Block Diagram

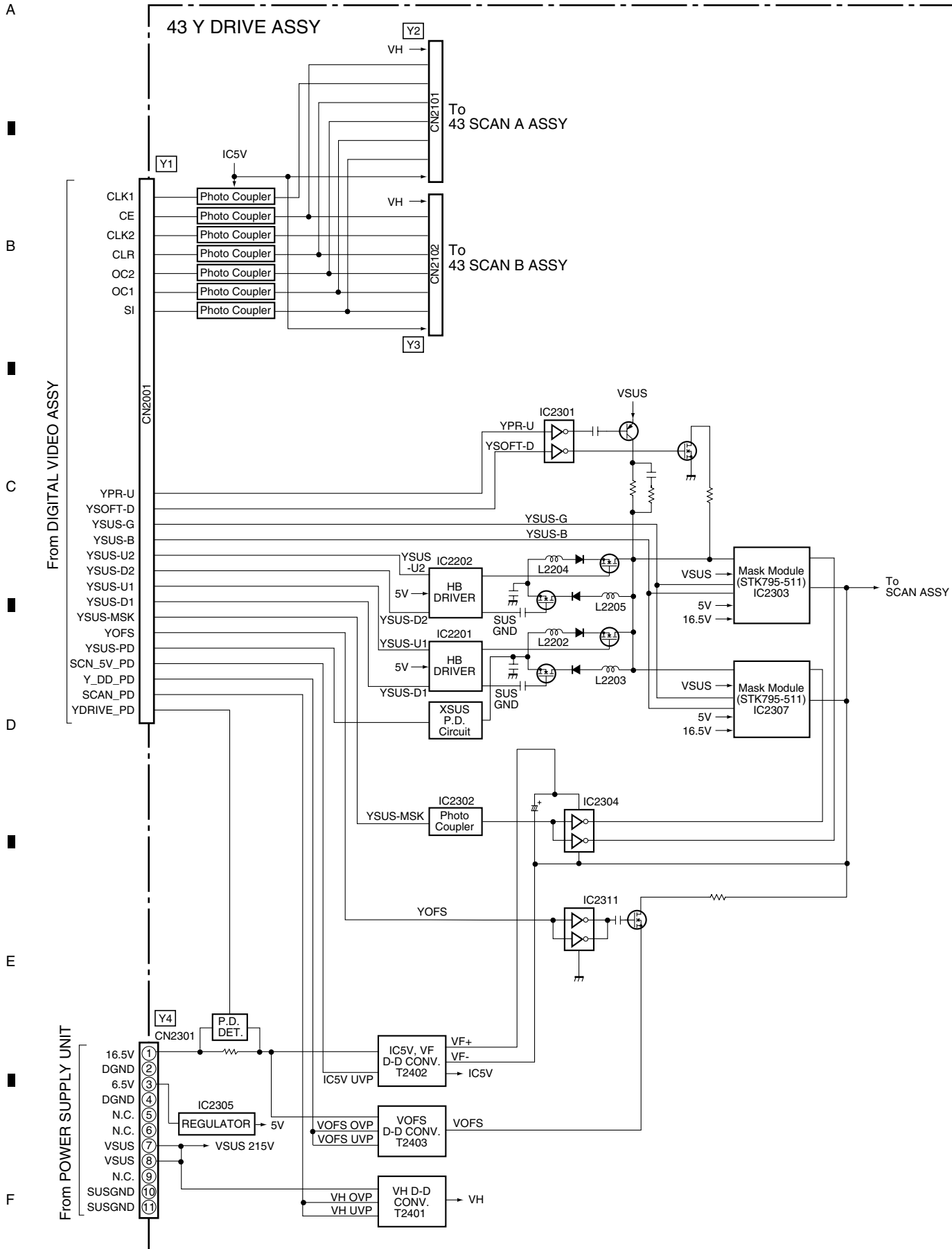

3.1.7 50 X DRIVE ASSY

• Block Diagram

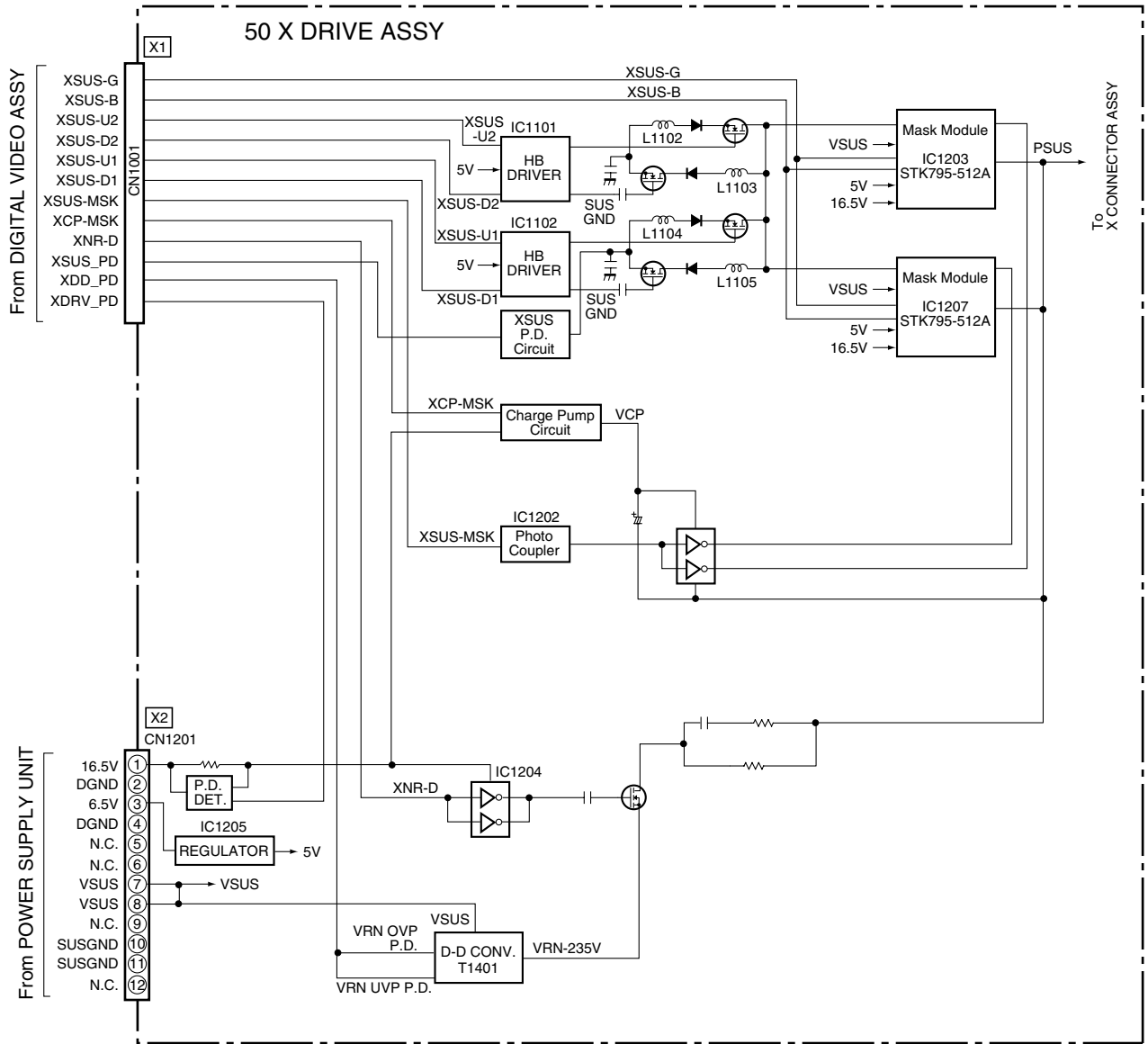

3.1.8 43 X DRIVE ASSY

• Block Diagram

A

B

C

D

E

F

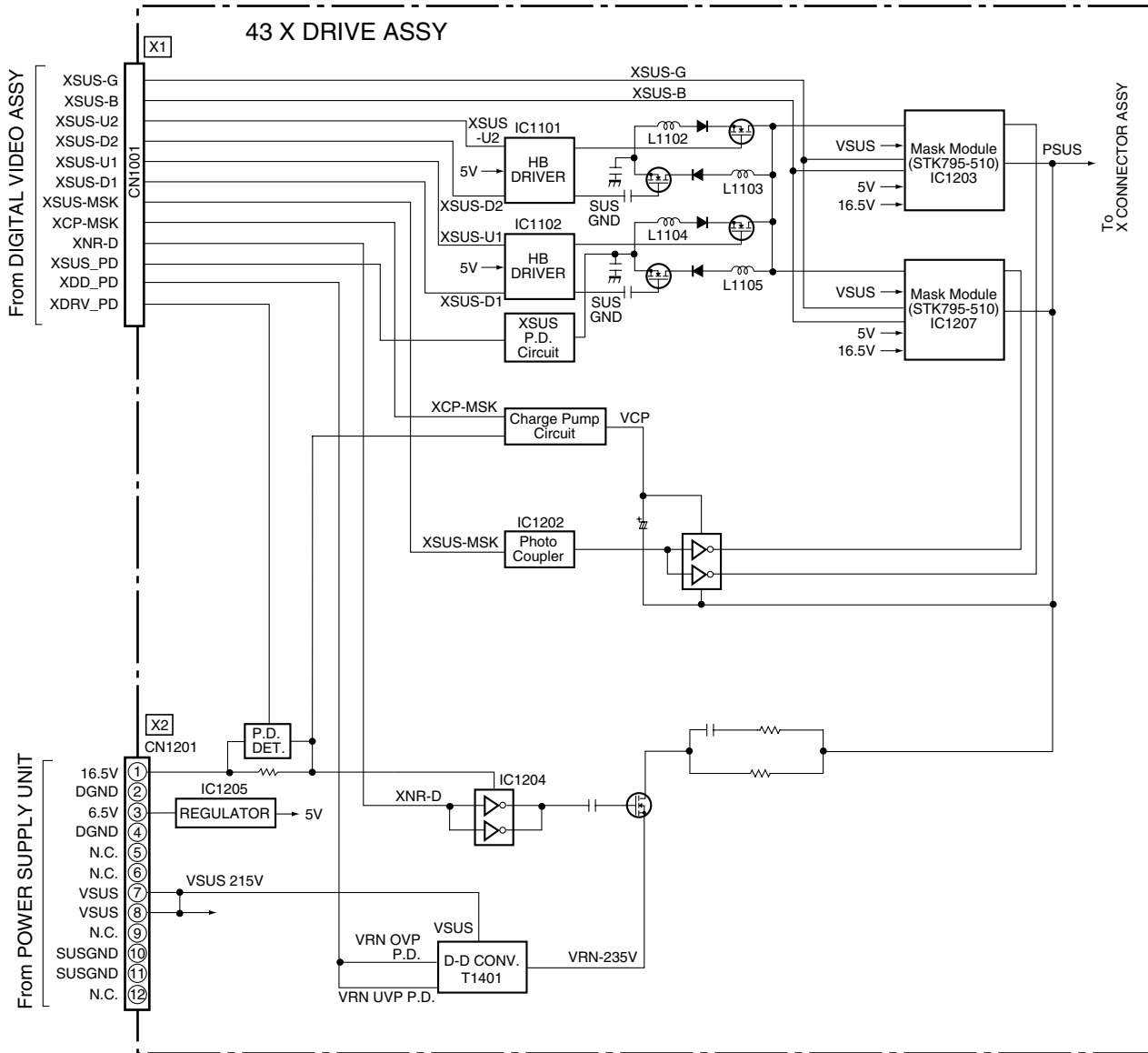

3.1.9 DIGITAL VIDEO ASSY

• Block Diagram

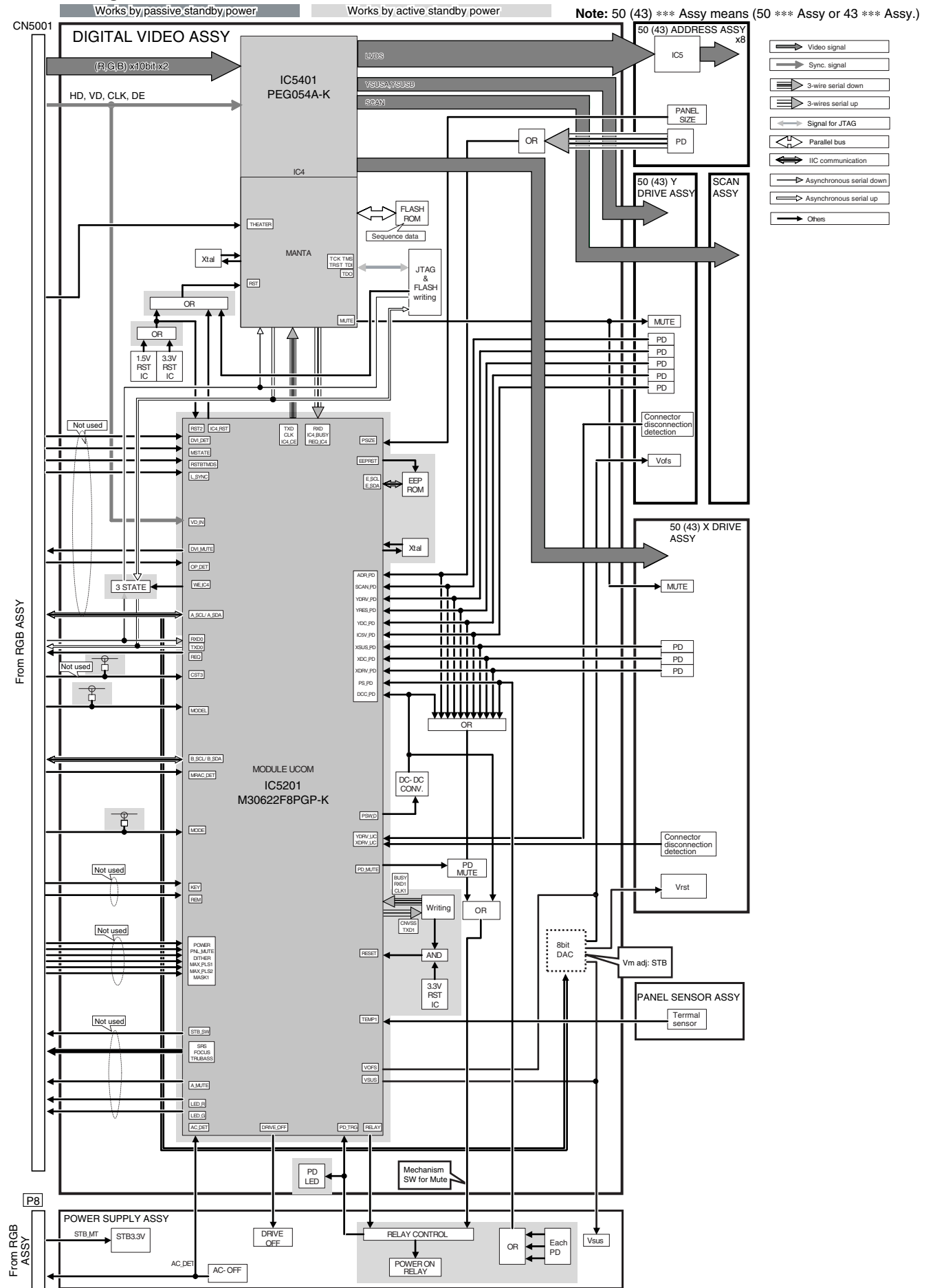

3.1.10 AV I/O ASSY

• Block Diagram

A

B

C

D

E

F

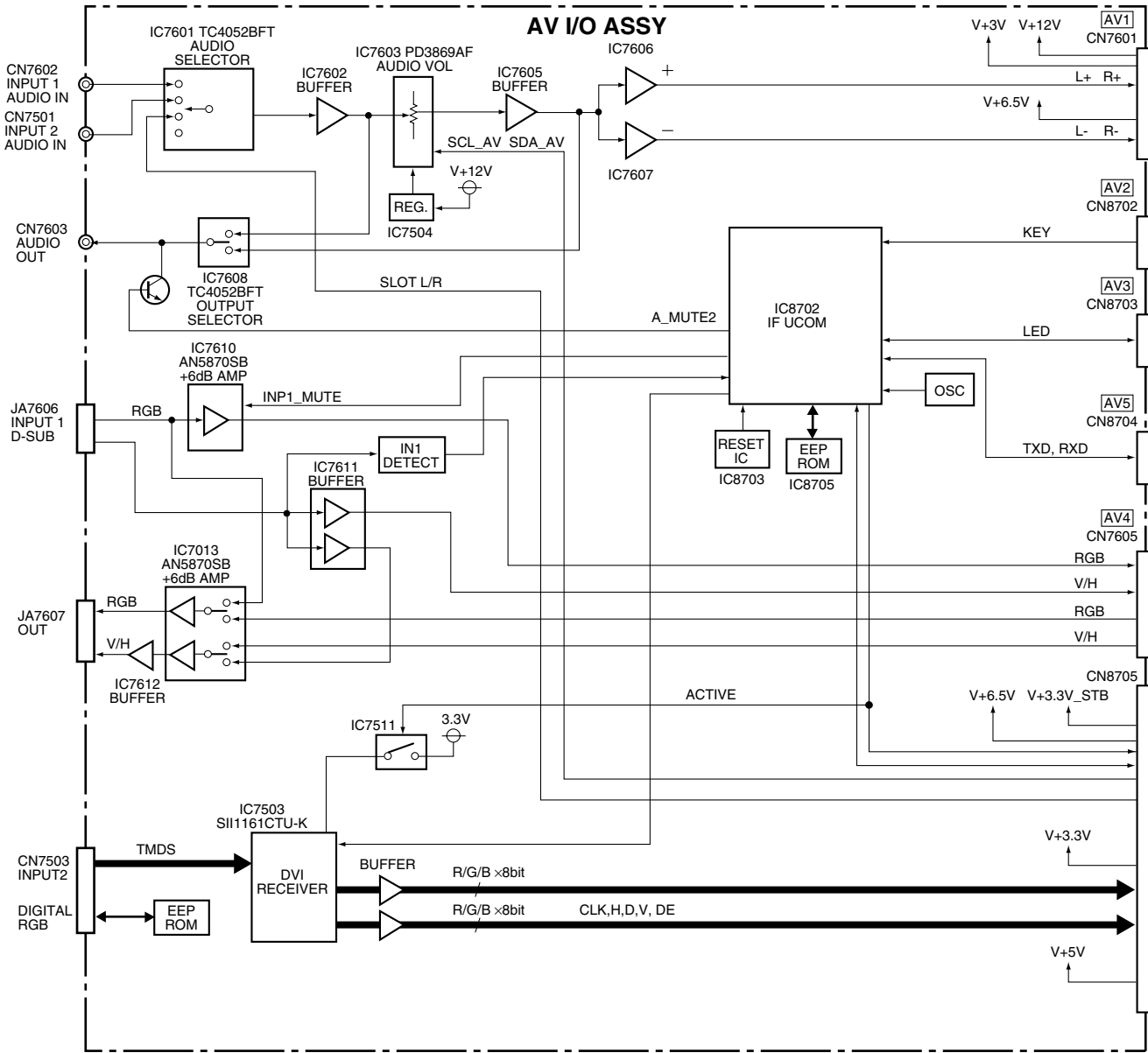

3.1.11 RGB ASSY

• Block Diagram

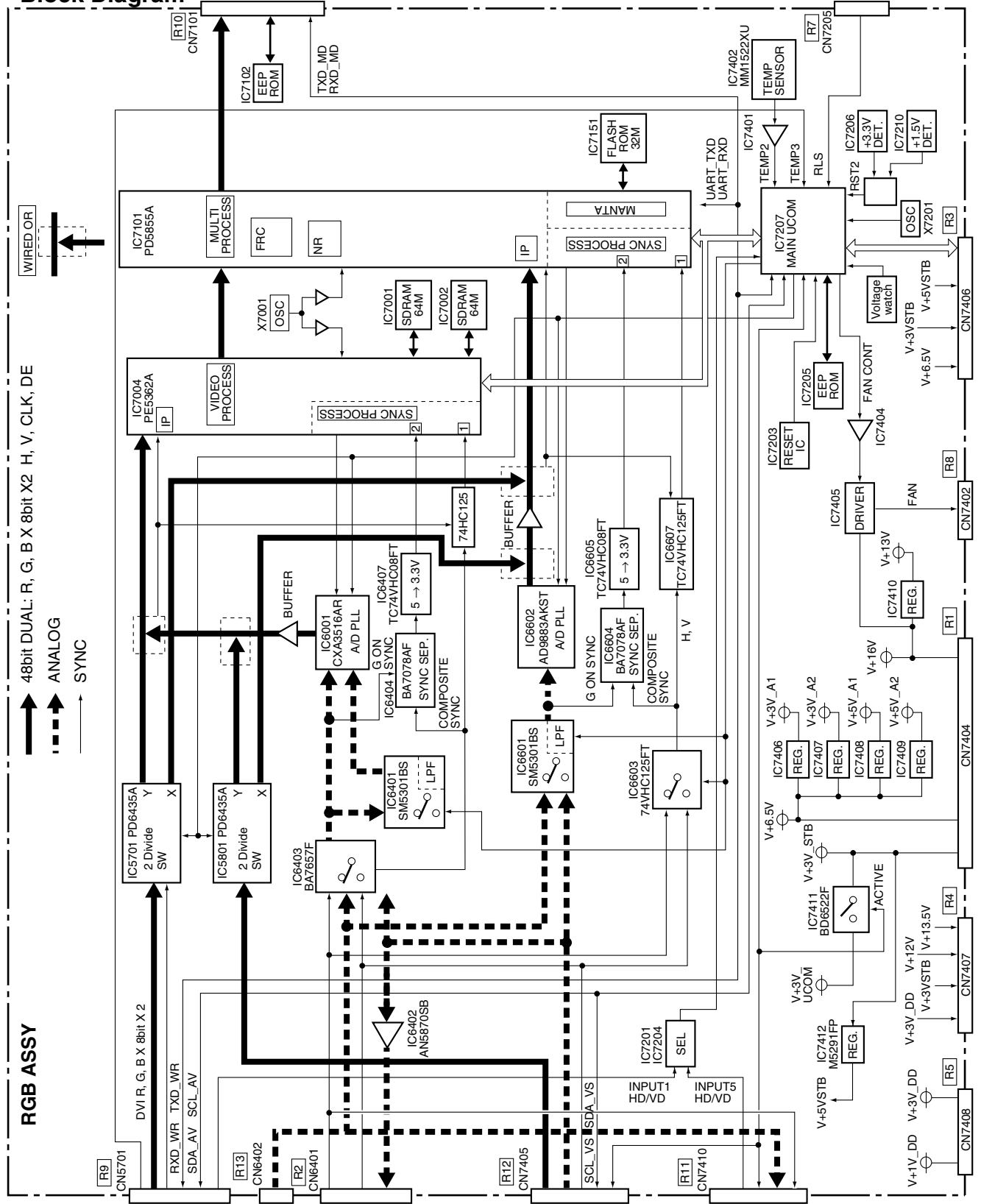

3.1.12 AUDIO AMP and COMM SLOT ASSYS

• Block Diagram

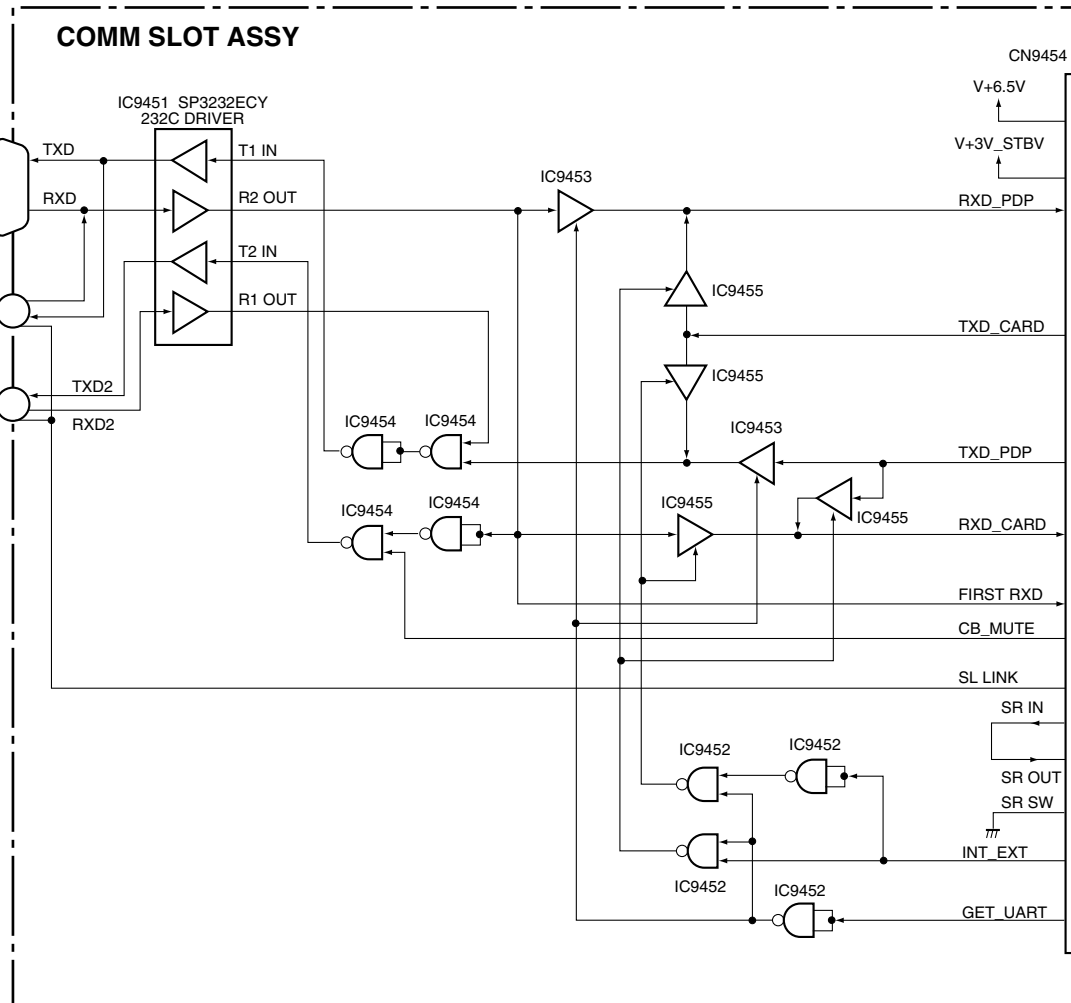
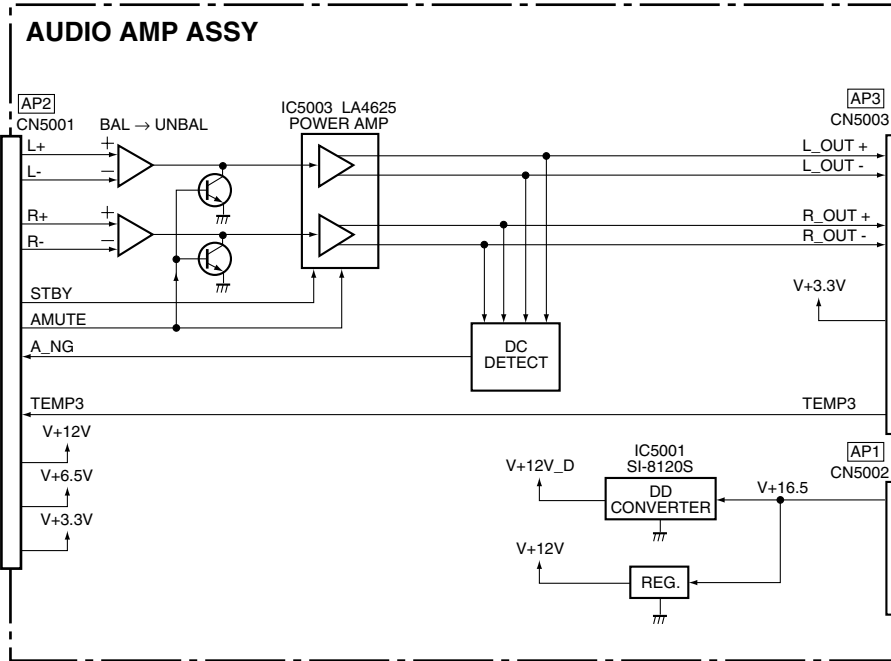

3.2 WAVEFORMS

DIGITAL VIDEO ASSY (4/6) • DIGITAL I/F BLOCK

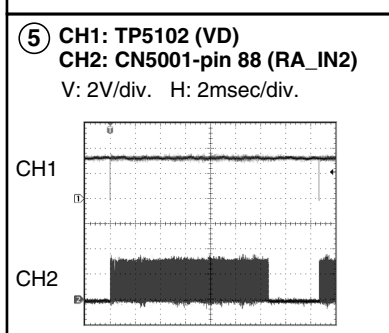
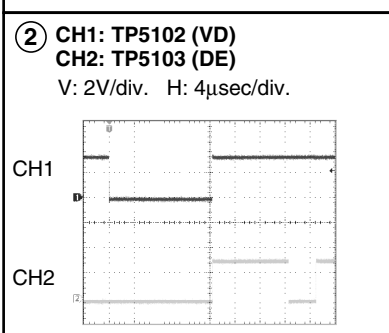
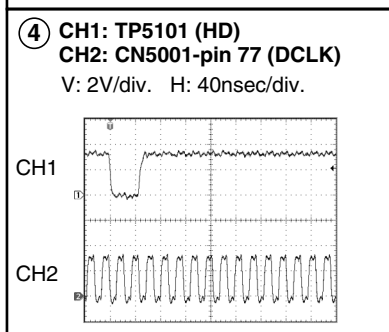
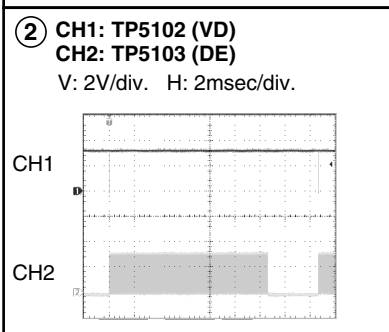
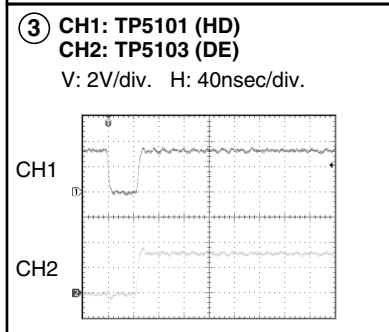
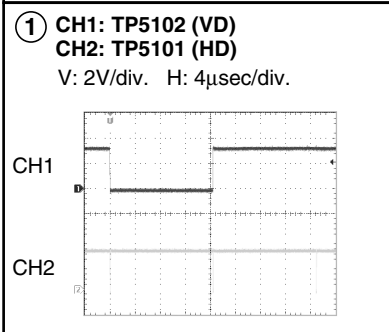
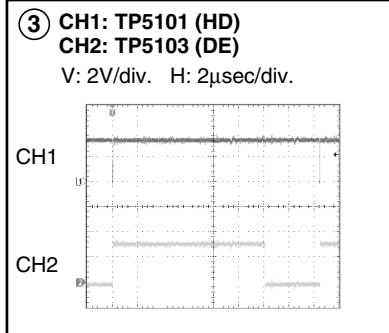
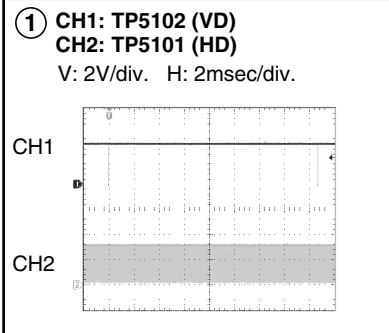

RGB ASSY (2/10, 3/10, 4/10)

MAIN AD BLOCK, MAIN LPF BLOCK, SUS LPF&AD BLOCK

Input: INPUT 1

Signal: RGB, XGA 60 Hz, Color-bar

⑫ to ⑳, ㉒ : With two screens, a SUB screen chooses INPUT1 and observes it.

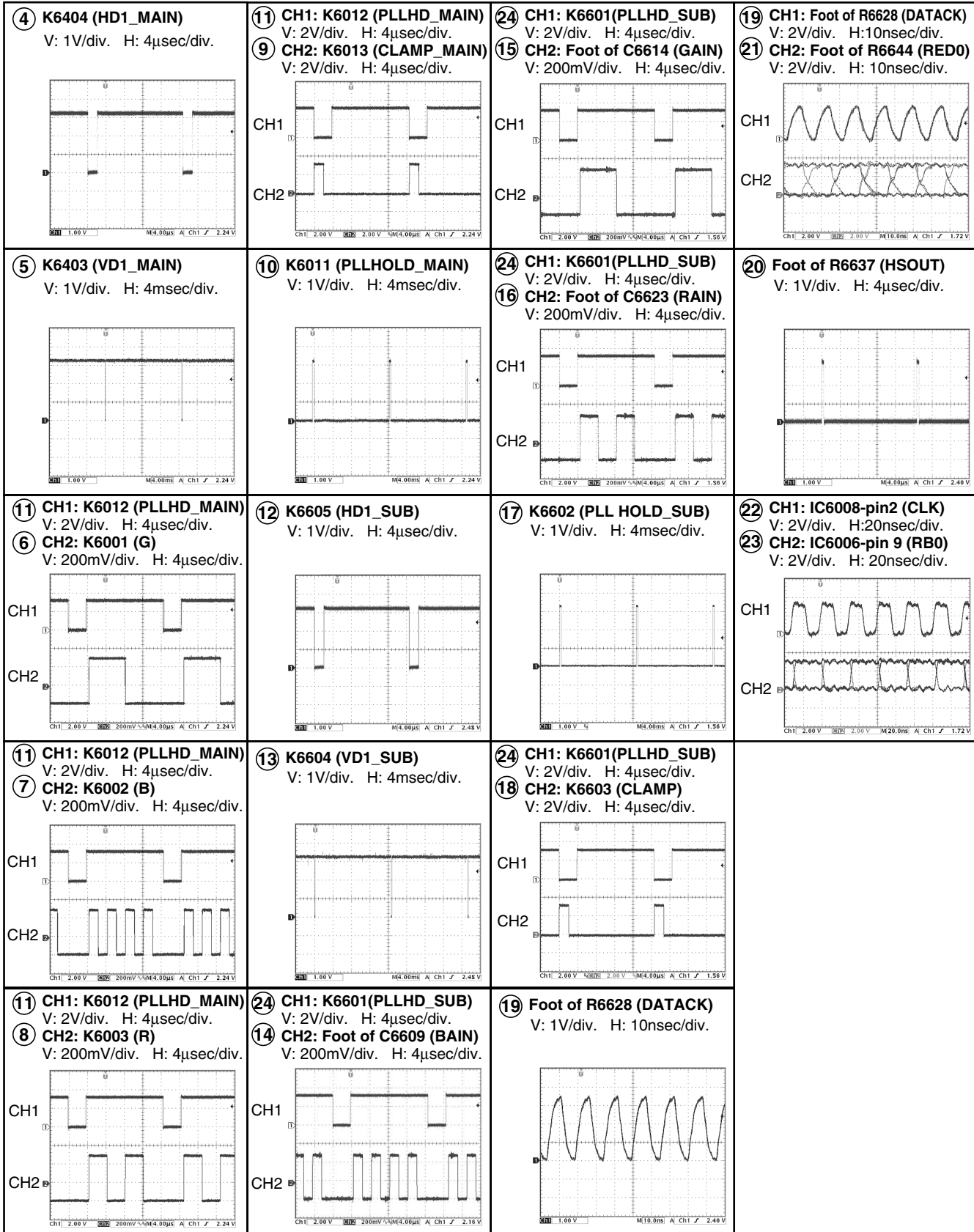

AV I/O ASSY (1/3)

• VIDEO • AV/I/O BLOCK
 Input: INPUT 1
 Signal: RGB, XGA 60 Hz, Color-bar

• AUDIO
 Input: INPUT 1
 Signal: 200mVrms, 1 kHz input, VOL MAX

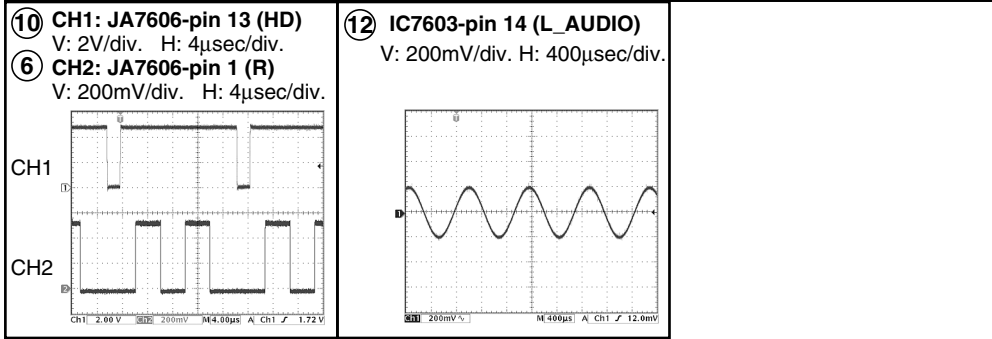
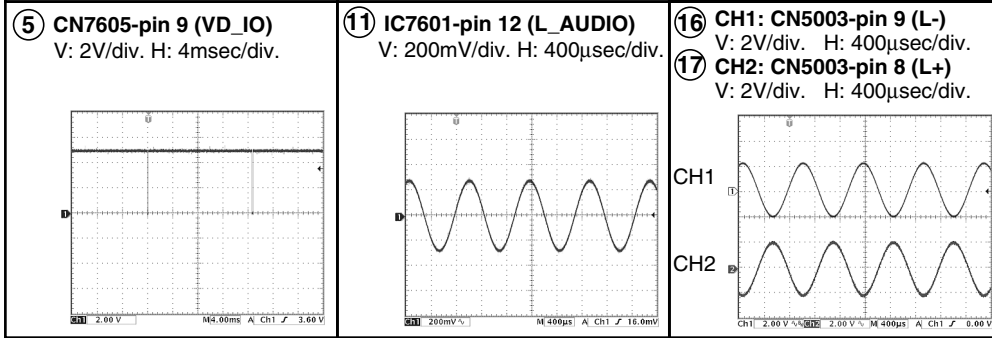
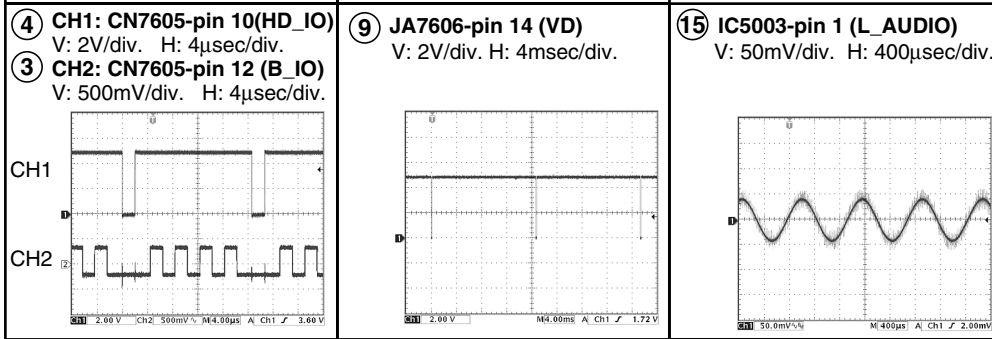
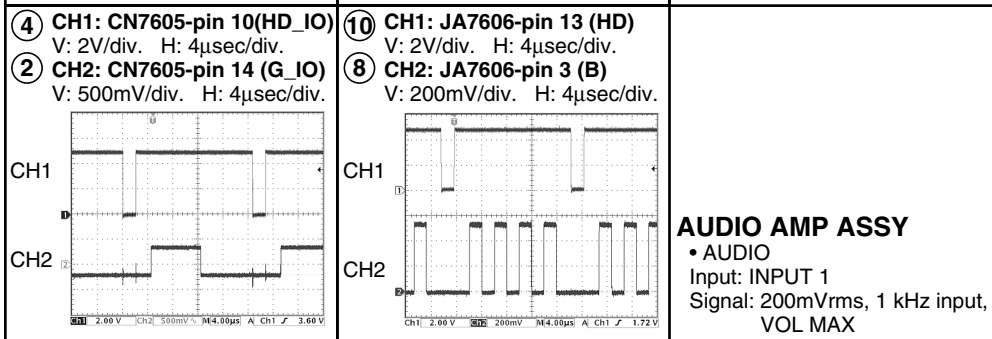
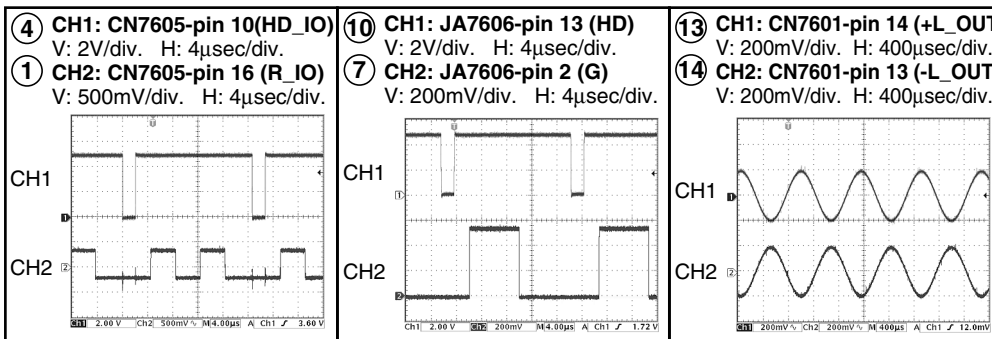

50 (43) X DRIVE ASSY, 50 (43) Y DRIVE ASSY and 50 (43) SCAN A ASSY

• 50 (43) X SUS BLOCK, 50 (43) Y LOGIC BLOCK, 50 (43) Y SUS BLOCK

Note:
50 (43) *** Assy means (50 *** Assy or 43 *** Assy.)

A

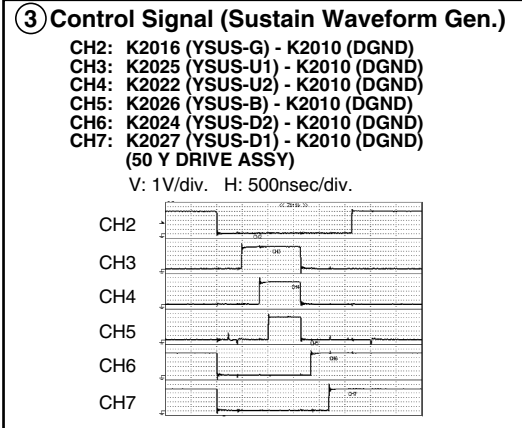
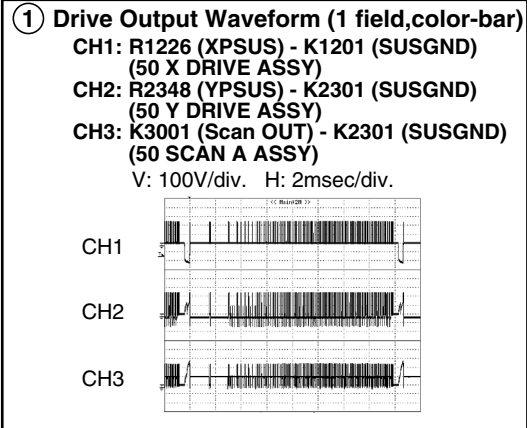

B

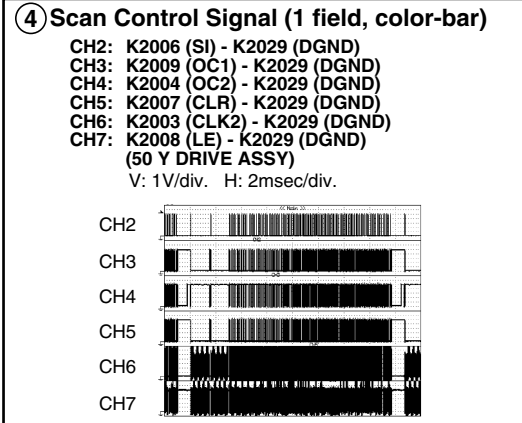
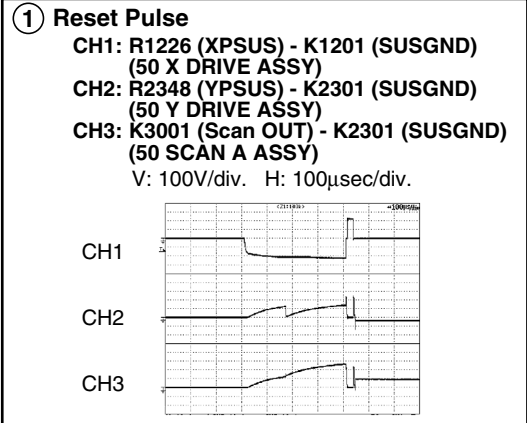

C

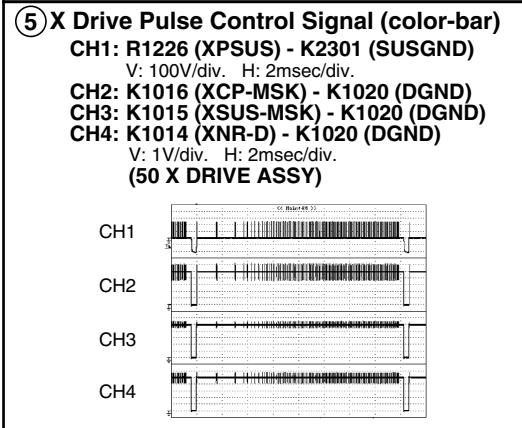
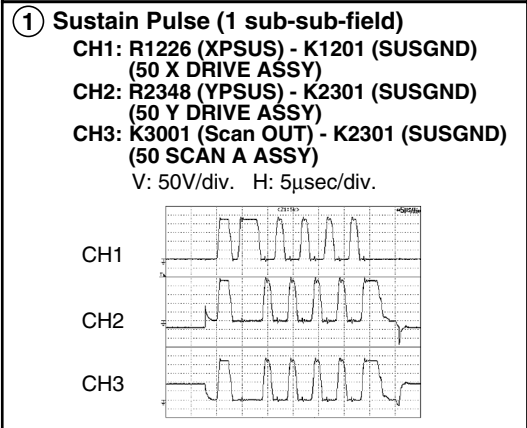

D

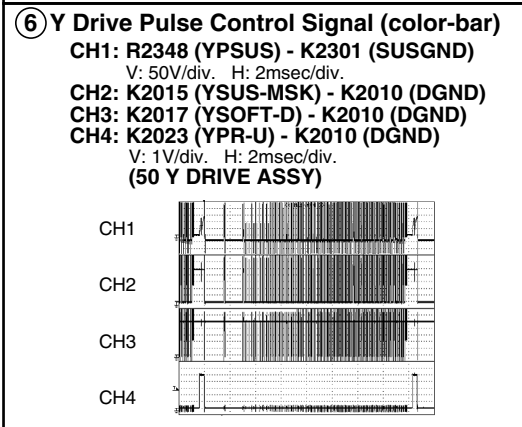
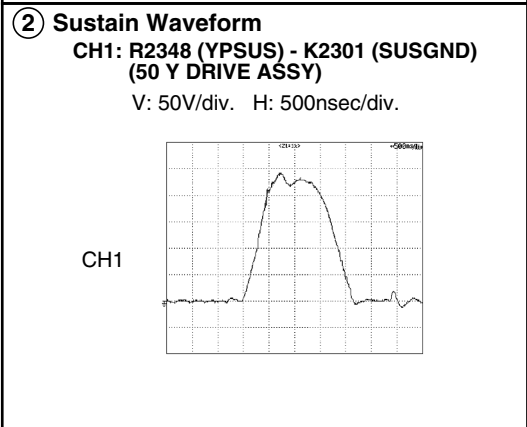

E

F

50 (43) ADDRESS ASSY

• ADR RESONANCE BLOCK (VIDEO and PC)

Note:

50 (43) *** Assy means

50 *** Assy or 43 *** Assy.

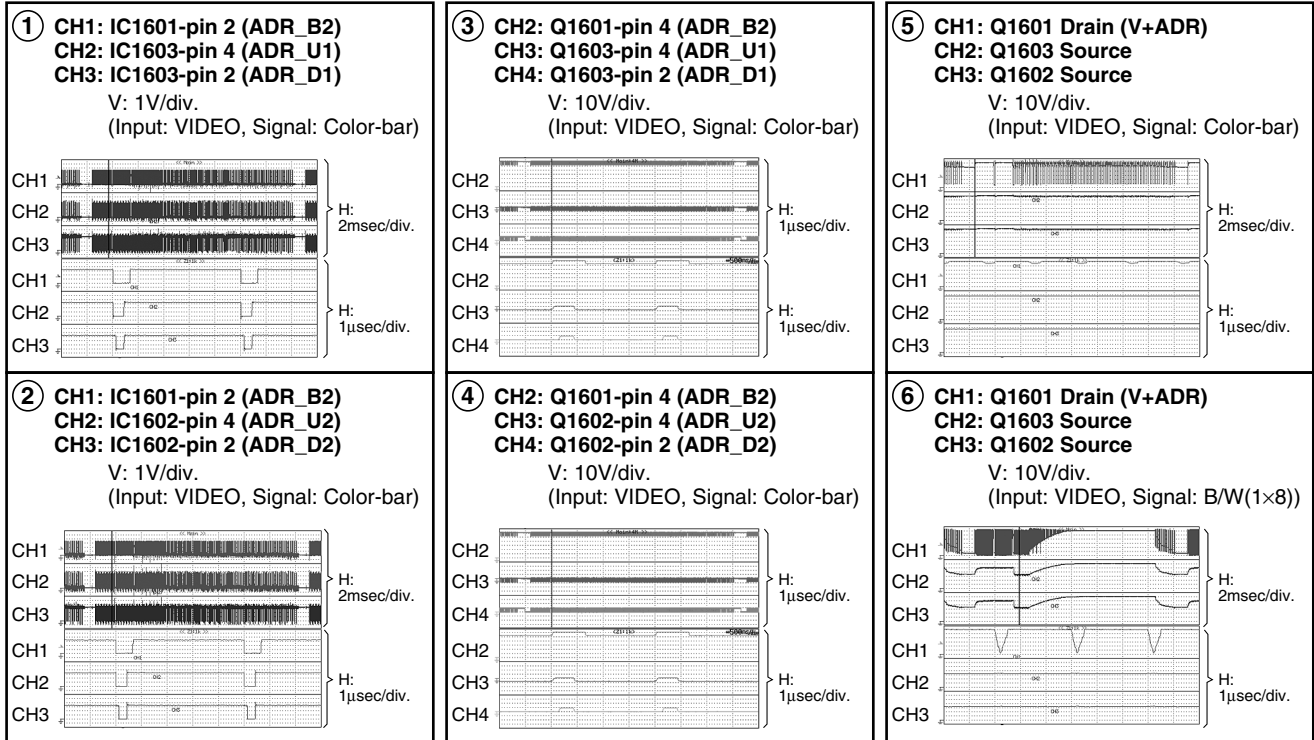

50 ADDRESS ASSY

• ADR LOGIC BLOCK

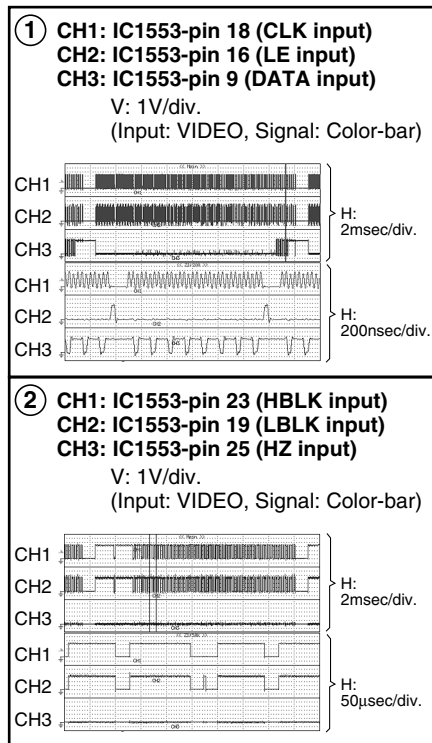

43 ADDRESS ASSY

• ADR LOGIC BLOCK

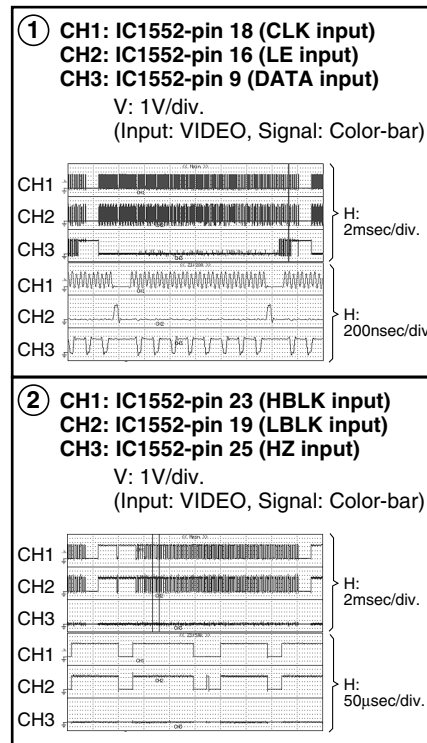

3.3 VOLTAGES

• Voltages

DIGITAL VIDEO ASSY

CN5601 (D1)

No.	Signal Name	I/O	Signal Description	Voltages at NTSC Signal Input
1	+12V	I	+12V power input	+12VDC
2	+12V	I	+12V power input	+12VDC
3	GND_D	-	GND	
4	GND_D	-	GND	
5	PD	O	Power down signal	0VDC
6	VSUS_ADJ	O	VSUS adjustment signal	
7	PS_PD	I	Power-down detecting signal of POWER SUPPLY block	0VDC
8	RELAY	O	Relay control signal	+3.3VDC
9	DRF	O	Drive control signal	0VDC
10	AC_DET	I	Primary side power (AC) state output at panel side	+3.0VDC
11	PD_TRIGGER	I	Power down trigger	+3.3VDC

CN5602 (D2)

No.	Signal Name	I/O	Signal Description	Voltages at NTSC Signal Input
1	VADR	I	Address drive power (+61V) input	+61VDC
2	VADR	I	Address drive power (+61V) input	+61VDC
3	N.C		Not connected	
4	GND_ADR	-	GND	
5	GND_ADR	-	GND	
6	+6.5V	I	+6.5V power input	+6.8VDC
7	GND_D	-	GND	

RGB ASSY

POWER SUPPLY ASSY

R1 (CN7404)		Voltage (V)	P8	
No.	Name		Name	No.
1	V+16.5V	16.7	V+16.5V	1
2	GND	0	GND	2
3	V+12V	12.9	V+12V	3
4	V+12V	12.9	V+12V	4
5	GND	0	GND	5
6	GND	0	GND	6
7	V+6.5V	6.8	V+6.5V	7
8	V+6.5V	6.8	V+6.5V	8
9	GND	0	GND	9
10	GND	0	GND	10
11	V+3V_STB	3.3	V+3V_STB	11
12	GND	0	GND	12
13	AC_DET	3.3	AC_DET	13

RGB ASSY

VIDEO SLOT I/F ASSY

R4 (CN7407)		Voltage (V)	VS1 (CN8951)	
No.	Name		Name	No.
1	GND	0	GND	1
2	GND	0	GND	2
3	V+13V	13.6	V+13V	3
4	V+13V	13.6	V+13V	4
5	V+12V	12.9	V+12V	5
6	V+12V	12.9	V+12V	6
7	GND	0	GND	7
8	V+3V_STB	3.3	V+3V_STB	8
9	GND	0	GND	9
10	V+3V_DD	3.3	V+3V_DD	10
11	V+3V_DD	3.3	V+3V_DD	11
12	GND	0	GND	12

RGB ASSY

AV I/O ASSY

R2 (CN6401)		Voltage (V)	AV4 (CN7605)	
No.	Name		Name	No.
1	VD_SLOT	0	VD_SLOT	1
2	HD_SLOT	0	HD_SLOT	2
3	GNDD	0	GNDD	3
4	B_SLOT	0	B_SLOT	4
5	GNDD	0	GNDD	5
6	G_SLOT	0	G_SLOT	6
7	GNDD	0	GNDD	7
8	R_SLOT	0	R_SLOT	8
9	VD_IO	5	VD_IO	9
10	HD_IO	4.5	HD_IO	10
R13 (CN6402)				
1	GNDD	0	GNDD	11
2	B_IO	0	B_IO	12
3	GNDD	0	GNDD	13
4	G_IO	0	G_IO	14
5	GNDD	0	GNDD	15
6	R_IO	0	R_IO	16

RGB ASSY

DIGITAL VIDEO ASSY

R5 (CN7408)		Voltage (V)	D3 (CN5002)	
No.	Name		Name	No.
1	V+1V_DD	1.4	V+1V_DD	1
2	V+1V_DD	1.4	V+1V_DD	2
3	V+1V_DD	1.4	V+1V_DD	3
4	GND	0	GND	4
5	GND	0	GND	5
6	GND	0	GND	6
7	V+3V_DD	3.3	V+3V_DD	7
8	V+3V_DD	3.3	V+3V_DD	8
9	GND	0	GND	9
10	GND	0	GND	10
11	NC			
12	NC			

RGB ASSY

COMM SLOT I/F ASSY

R3 (CN7406)		Voltage (V)	CS2 (CN8902)	
No.	Name		Name	No.
1	V+5V_STB	5.1	V+5V_STB	1
2	GND	0	GND	2
3	V+3V_STB	3.3	V+3V_STB	3
4	CYOB1	3.3	CYOB1	4
5	CYOB2	0	CYOB2	5
6	CYOB3	0	CYOB3	6
7	GND	0	GND	7
8	SR_OUT	4.9	SR_OUT	8
9	SLOT_ST_COM	3.3	SLOT_ST_COM	9
10	V+6V	6.8	V+6V	10
11	NC	0	NC	11

RGB ASSY

LED OPT ASSY (OPT)

R7 (CN7205)		Voltage (V)	LO2 (CN9051)	
No.	Name		Name	No.
1	3.3V	3.3	3.3V	1
2	RLS	0-3.3	RLS	2
3	GND	0	GND	3
4	GND	0	GND	4

RGB ASSY

FAN (L), (R)

R8 (CN7402)		Voltage (V)	FAN (L)	
No.	Name		Name	No.
1	FAN_12V	0	FAN_12V	1
2	FAN_NG	3.2	FAN_NG	2
3	GND	0	GND	3
			FAN (R)	
4	FAN_12V	0	FAN_12V	1
5	FAN_NG	3.2	FAN_NG	2
6	GND	0	GND	3
7	NC			

RGB ASSY

R9 (CN5701)				
No.	Name			
AV I/O IF ASSY		AV I/O ASSY		
CN2102, AV6 (CN2101)		Voltage (V)	CN8705	
No.	Name		Name	No.
1	N.C.	0	N.C.	101
2	N.C.	0	N.C.	102
3	A_R_SLOT	0	A_R_SLOT	103
4	GND	0	GND	104
5	A_L_SLOT	0	A_L_SLOT	105
6	GND	0	GND	106
7	V+12V	12.9	V+12V	107
8	GND	0	GND	108
9	1N1_HD	4.4	1N1_HD	109
10	1N1_VD	4.8	1N1_VD	110
11	WE_ROM_B	0	WE_ROM_B	111
12	KEY	3.3	KEY	112
13	IO_YOBI2	0	IO_YOBI2	113
14	SR_OUT	5	SR_OUT	114
15	RXD_IF	3.3	RXD_IF	115
16	CLK_IF	3.3	CLK_IF	116
17	RXD_WR	3.3	RXD_WR	117
18	REQ_IF	0	REQ_IF	118
19	RST_IF	0	RST_IF	119
20	IF_CE	3.2	IF_CE	120
21	HOT_P1	0	HOT_P1	121
22	HDMI2_SDA	0	HDMI2_SDA	122
23	HDMI_INT1	3.2	HDMI_INT1	123
24	SCL_AV	3.3	SCL_AV	124
25	HDMI_AUDIO_CLK	0	HDMI_AUDIO_CLK	125
26	D_AUDIO_SEL	0	D_AUDIO_SEL	126
27	CEC2	0	CEC2	127
28	GND	0	GND	128
29	HD_DVI	0	HD_DVI	129
30	DE_DVI	0	DE_DVI	130
31	GND	0	GND	131
32	RB_DVI7	0/3.3	RB_DVI7	132
33	RB_DVI6	0/3.3	RB_DVI6	133
34	RB_DVI4	0/3.3	RB_DVI4	134
35	RB_DVI2	0/3.3	RB_DVI2	135
36	RB_DVI0	0/3.3	RB_DVI0	136
37	GB_DVI6	0/3.3	GB_DVI6	137
38	GB_DVI4	0/3.3	GB_DVI4	138
39	GB_DVI2	0/3.3	GB_DVI2	139
40	GB_DVI0	0/3.3	GB_DVI0	140
41	BB_DVI6	0/3.3	BB_DVI6	141
42	BB_DVI4	0/3.3	BB_DVI4	142
43	BB_DVI2	0/3.3	BB_DVI2	143
44	BB_DVI0	0/3.3	BB_DVI0	144
45	RA_DVI7	0/3.3	RA_DVI7	145
46	RA_DVI5	0/3.3	RA_DVI5	146
47	RA_DVI3	0/3.3	RA_DVI3	147
48	RA_DVI1	0/3.3	RA_DVI1	148
49	GND	0	GND	149
52	GA_DVI7	0/3.3	GA_DVI7	152
53	GA_DVI5	0/3.3	GA_DVI5	153
54	GA_DVI3	0/3.3	GA_DVI3	154
55	GA_DVI1	0/3.3	GA_DVI1	155
56	BA_DVI7	0/3.3	BA_DVI7	156

RGB ASSY

R9 (CN5701)				
No.	Name			
AV I/O IF ASSY		AV I/O ASSY		
CN2102, AV6 (CN2101)		Voltage (V)	CN8705	
No.	Name		Name	No.
57	BA_DVI5	0/3.3	BA_DVI5	157
58	BA_DVI3	0/3.3	BA_DVI3	158
59	GND	0	GND	159
60	V+5V_A2	5	V+5V_A2	160
61	N.C.	0	N.C.	161
62	N.C.	0	N.C.	162
101	N.C.	0	N.C.	1
102	N.C.	0	N.C.	2
103	A_MUTE	0	A_MUTE	3
104	TEMP3	0A 3.3	TEMP3	4
105	V+6V	6.8	V+6V	5
106	GND	0	GND	6
107	V+3V_A1	3.3	V+3V_A1	7
108	GND	0	GND	8
109	V+3V_UCOM	3.3	V+3V_UCOM	9
110	GND	0	GND	10
111	V+3VSTB	3.3	V+3VSTB	11
112	IO_YOBI1	0	IO_YOBI1	12
113	PN2	0	PN2	13
114	ACTIVE	3.2	ACTIVE	14
115	TXD_IF	3.3	TXD_IF	15
116	TXD_WR	3.3	TXD_WR	16
117	AC_DET	3	AC_DET	17
118	IF_BUSY	0	IF_BUSY	18
119	RESET	3.3	RESET	19
120	HDMI_AUDIO_CE	0	HDMI_AUDIO_CE	20
121	HOT_P2	0	HOT_P2	21
122	HDMI2_SCL	0	HDMI2_SCL	22
123	SDA_AV	3.2	SDA_AV	23
124	HDMI_INT2	3.2	HDMI_INT2	24
125	HDMI_AUDIO_TXD	0	HDMI_AUDIO_TXD	25
126	CEC1	2	CEC1	26
127	RESETX1	3.3	RESETX1	27
128	VD_DVI	0	VD_DVI	28
129	GND	0	GND	29
130	CLK_DVI	0	CLK_DVI	30
131	GND	0	GND	31
132	GND	0	GND	32
133	RB_DVI5	0/3.3	RB_DVI5	33
134	RB_DVI3	0/3.3	RB_DVI3	34
135	RB_DVI1	0/3.3	RB_DVI1	35
136	GB_DVI7	0/3.3	GB_DVI7	36
137	GB_DVI5	0/3.3	GB_DVI5	37
138	GB_DVI3	0/3.3	GB_DVI3	38
139	GB_DVI1	0/3.3	GB_DVI1	39
140	GND	0	GND	40
141	BB_DVI6	0/3.3	BB_DVI6	41
142	BB_DVI4	0/3.3	BB_DVI4	42
143	BB_DVI2	0/3.3	BB_DVI2	43
144	BB_DVI0	0/3.3	BB_DVI0	44
145	RA_DVI6	0/3.3	RA_DVI6	45
146	RA_DVI4	0/3.3	RA_DVI4	46
147	RA_DVI2	0/3.3	RA_DVI2	47
148	RA_DVI0	0/3.3	RA_DVI0	48

RGB ASSY

R9 (CN5701)				
No.	Name			
AV I/O IF ASSY		AV I/O ASSY		
CN2102, AV6 (CN2101)		Voltage (V)	CN8705	
No.	Name		Name	No.
149	GND	0	GND	49
152	GA_DVI6	0/3.3	GA_DVI6	52
153	GA_DVI4	0/3.3	GA_DVI4	53
154	GA_DVI2	0/3.3	GA_DVI2	54
155	GA_DVI0	0/3.3	GA_DVI0	55
156	BA_DVI6	0/3.3	BA_DVI6	56
157	BA_DVI4	0/3.3	BA_DVI4	57
158	BA_DVI2	0/3.3	BA_DVI2	58
159	BA_DVI1	0/3.3	BA_DVI1	59
160	BA_DVI0	0/3.3	BA_DVI0	60
161	NC	0	NC	61
162	NC	0	NC	62

RGB ASSY

VIDEO SLOT I/F ASSY

R11 (CN7410)		Voltage (V)	VS3 (CN8955)	
No.	Name		Name	No.
38	GND	0	GND	38
39	GND	0	GND	39
40	DSUBV	5	DSUBV	40
41	GND	0	GND	41
42	GND	0	GND	42
43	IN5_VD	3.3	IN5_VD	43
44	GND	0	GND	44
45	GND	0	GND	45
46	HYOUJI_X	0	HYOUJI_X	46
47	VYOB14	0	VYOB14	47
48	VYOB15	0	VYOB15	48
49	VYOB16	0	VYOB16	49
50	WE_ROM_B	0	WE_ROM_B	50

RGB ASSY

VIDEO SLOT I/F ASSY

R11 (CN7410)		Voltage (V)	VS3 (CN8955)	
No.	Name		Name	No.
1	GND	0	GND	1
2	KEY	3.3	KEY	2
3	EMGREQ1_V	0	EMGREQ1_V	3
4	EMGREQ2_V	0	EMGREQ2_V	4
5	IC1V_OE	3.3	IC1V_OE	5
6	RESETX1	3.3	RESETX1	6
7	GND	0	GND	7
8	SD_SEL	3.3	SD_SEL	8
9	FNC2	0	FNC2	9
10	FNC3	0	FNC3	10
11	SOUND1	3.3	SOUND1	11
12	GND	0	GND	12
13	DSUBR	3.77	DSUBR	13
14	GND	0	GND	14
15	DSUBG	0	DSUBG	15
16	GND	0	GND	16
17	DSUBB	3.8	DSUBB	17
18	GND	0	GND	18
19	GND	0	GND	19
20	IN5_HD	0	IN5_HD	20
21	GND	0	GND	21
22	SOUSA_X	3.3	SOUSA_X	22
23	VYOB11	0	VYOB11	23
24	VYOB12	0	VYOB12	24
25	DSUBSW_DET	0	DSUBSW_DET	25
26	GND	0	GND	26
27	GND	0	GND	27
28	GND	0	GND	28
29	EMGREQ1_S	0	EMGREQ1_S	29
30	EMGREQ2_S	0	EMGREQ2_S	30
31	IC1S_OE	0	IC1S_OE	31
32	SLOT_ST3	0.4	SLOT_ST3	32
33	M_CHOICE	0	M_CHOICE	33
34	SOUND2	0	SOUND2	34
35	GND	0	GND	35
36	GND	0	GND	36
37	DSUBH	4.5	DSUBH	37

RGB ASSY

VIDEO SLOT I/F ASSY

R12 (CN7405)		Voltage (V)	VS4 (CN8953)	
No.	Name		Name	No.
1	GND	0	GND	1
2	GND	0	GND	2
3	G_SLOT	0	G_SLOT	3
4	GND	0	GND	4
5	B_SLOT	0	B_SLOT	5
6	GND	0	GND	6
7	R_SLOT	0	R_SLOT	7
8	GND	0	GND	8
9	HD_SLOT	0	HD_SLOT	9
10	GND	0	GND	10
11	VD_SLOT	0	VD_SLOT	11
12	GND	0	GND	12
13	AUDIO_L_SLOT	6	AUDIO_L_SLOT	13
14	GND	0	GND	14
15	AUDIO_R_SLOT	6	AUDIO_R_SLOT	15
16	GND	0	GND	16
17	SLOT_ST1	0	SLOT_ST1	17
18	S_DIN_SEL	0	S_DIN_SEL	18
19	FNC_1	0	FNC_1	19
20	FNC_0	5	FNC_0	20
21	NC	0	NC	21
22	NC	0	NC	22
23	VD_DET	0	VD_DET	23
24	GND	0	GND	24
25	HD_DET	0	HD_DET	25
26	GND	0	GND	26
27	VD_IC1	3.2	VD_IC1	27
28	GND	0	GND	28
29	HD_IC1	3	HD_IC1	29
30	GND	0	GND	30
31	GND	0	GND	31
32	RB0_IC1	0/3.3	RB0_IC1	32
33	RB1_IC1	0/3.3	RB1_IC1	33
34	RB2_IC1	0/3.3	RB2_IC1	34
35	RB3_IC1	0/3.3	RB3_IC1	35
36	RB4_IC1	0/3.3	RB4_IC1	36
37	RB5_IC1	0/3.3	RB5_IC1	37

RGB ASSY

VIDEO SLOT I/F ASSY

No.	R12 (CN7405)		VS4 (CN8953)	
	Name	Voltage (V)	Name	No.
38	RB6_IC1	0/3.3	RB6_IC1	38
39	RB7_IC1	0/3.3	RB7_IC1	39
40	GND	0	GND	40
41	GND	0	GND	41
42	GB0_IC1	0/3.3	GB0_IC1	42
43	GB1_IC1	0/3.3	GB1_IC1	43
44	GB2_IC1	0/3.3	GB2_IC1	44
45	GB3_IC1	0/3.3	GB3_IC1	45
46	GB4_IC1	0/3.3	GB4_IC1	46
47	GB5_IC1	0/3.3	GB5_IC1	47
48	GB6_IC1	0/3.3	GB6_IC1	48
49	GB7_IC1	0/3.3	GB7_IC1	49
50	GND	0	GND	50
51	GND	0	GND	51
52	BB0_IC1	0/3.3	BB0_IC1	52
53	BB1_IC1	0/3.3	BB1_IC1	53
54	BB2_IC1	0/3.3	BB2_IC1	54
55	BB3_IC1	0/3.3	BB3_IC1	55
56	BB4_IC1	0/3.3	BB4_IC1	56
57	BB5_IC1	0/3.3	BB5_IC1	57
58	BB6_IC1	0/3.3	BB6_IC1	58
59	BB7_IC1	0/3.3	BB7_IC1	59
60	GND	0	GND	60
61	GND	0	GND	61
62	GND	0	GND	62
63	SCL_VS	3.1	SCL_VS	63
64	GND	0	GND	64
65	SDA_VS	3.1	SDA_VS	65
66	GND	0	GND	66
67	GND	0	GND	67
68	GND	0	GND	68
69	NC	0	NC	69
70	GND	0	GND	70
71	NC	0	NC	71
72	GND	0	GND	72
73	NC	0	NC	73
74	GND	0	GND	74
75	NC	0	NC	75
76	NC	0	NC	76
77	IN4_DET	0	IN4_DET	77
78	IN3_DET	0	IN3_DET	78
79	SLOT_ST2	3	SLOT_ST2	79
80	SR_VS	5.1	SR_VS	80
81	NC	0	NC	81
82	3G4G	3.3	3G4G	82
83	GND	0	GND	83
84	GND	0	GND	84
85	IN5_DET	0	IN5_DET	85
86	GND	0	GND	86
87	DE_IC1	2.5	DE_IC1	87
88	GND	0	GND	88
89	CK_IC1	1.5	CK_IC1	89
90	GND	0	GND	90
91	GND	0	GND	91
92	BA7_IC1	0/3.3	BA7_IC1	92
93	BA6_IC1	0/3.3	BA6_IC1	93
94	BA5_IC1	0/3.3	BA5_IC1	94

RGB ASSY

VIDEO SLOT I/F ASSY

No.	R12 (CN7405)		VS4 (CN8953)	
	Name	Voltage (V)	Name	No.
95	BA4_IC1	0/3.3	BA4_IC1	95
96	BA3_IC1	0/3.3	BA3_IC1	96
97	BA2_IC1	0/3.3	BA2_IC1	97
98	BA1_IC1	0/3.3	BA1_IC1	98
99	BA0_IC1	0/3.3	BA0_IC1	99
100	GND	0	GND	100
101	GND	0	GND	101
102	GA7_IC1	0/3.3	GA7_IC1	102
103	GA6_IC1	0/3.3	GA6_IC1	103
104	GA5_IC1	0/3.3	GA5_IC1	104
105	GA4_IC1	0/3.3	GA4_IC1	105
106	GA3_IC1	0/3.3	GA3_IC1	106
107	GA2_IC1	0/3.3	GA2_IC1	107
108	GA1_IC1	0/3.3	GA1_IC1	108
109	GA0_IC1	0/3.3	GA0_IC1	109
110	GND	0	GND	110
111	GND	0	GND	111
112	RA7_IC1	0/3.3	RA7_IC1	112
113	RA6_IC1	0/3.3	RA6_IC1	113
114	RA5_IC1	0/3.3	RA5_IC1	114
115	RA4_IC1	0/3.3	RA4_IC1	115
116	RA3_IC1	0/3.3	RA3_IC1	116
117	RA2_IC1	0/3.3	RA2_IC1	117
118	RA1_IC1	0/3.3	RA1_IC1	118
119	RA0_IC1	0/3.3	RA0_IC1	119
120	GND	0	GND	120
121	GND	0	GND	121
122	GND	0	GND	122

AV I/O ASSY

AUDIO AMP ASSY

No.	AV1 (CN7601)		AP2 (CN5001)	
	Name	Voltage (V)	Name	No.
1	A_NG	3.2	A_NG	15
2	TEMP3	0-3.3	TEMP3	14
3	A_MUTE	0	A_MUTE	13
4	ST_BY	2.5	ST_BY	12
5	GND	0	GND	11
6	V+6V	6.8	V+6V	10
7	V+3V	3.3	V+3V	9
8	V+12A	12	V+12A	8
9	GND	0	GND	7
10	-R_OUT	6	-R_OUT	6
11	+R_OUT	6	+R_OUT	5
12	GND	0	GND	4
13	-L_OUT	6	-L_OUT	3
14	+L_OUT	6	+L_OUT	2
15	GND	0	GND	1

AV I/O ASSY

KEY CONTROL ASSY

No.	AV2 (CN8702)		KY1 (CN9001)	
	Name	Voltage (V)	Name	No.
1	GND	0	GND	1
2	KEY	3.3	KEY	2
3	V+3VSTB	3.3	V+3VSTB	3

AV I/O ASSY

AV3 (CN8703)		Voltage (V)	LO1 (CN9651)	
No.	Name		Name	No.
1	V+3STB	3.3	V+3STB	1
2	LED_G	0	LED_G	2
3	LED_R	3.3	LED_R	3
4	GND	0	GND	4
5	AC_DET	3	AC_DET	5

LED OPT ASSY

COMM SLOT I/F ASSY

CS4 (CN8901)		Voltage (V)	RE1 (CN4901)	
No.	Name		Name	No.
1	V+3STB	3.3	V+3STB	1
2	GND	0	GND	2
3	SR	0	SR	3
4	GND	0	GND	4

IR ASSY

AV I/O ASSY

AV5 (CN8704)		Voltage (V)	CS1 (CN8905)	
No.	Name		Name	No.
1	STL_LINK	3.3	STL_LINK	1
2	CB_MUTE	3.3	CB_MUTE	2
3	KEY	3.3	KEY	3
4	RXD	3.3	RXD	4
5	TXD	3.3	TXD	5
6	GND	0	GND	6

COMM SLOT I/F ASSY

COMM SLOT I/F ASSY

CS5 (CN8904)		Voltage (V)	CN9454	
No.	Name		Name	No.
1	NC	0	NC	1
2	IRSW	0	IRSW	2
3	IR_COMM_OUT	5.1	IR_COMM_OUT	3
4	IR_COMM_IN	5.1	IR_COMM_IN	4
5	GND	0	GND	5
6	GND	0	GND	6
7	GND	0	GND	7
8	CYOB13	0	CYOB13	8
9	CYOB12	0	CYOB12	9
10	CSL_ST2	3.3	CSL_ST2	10
11	CSL_ST1	3.3	CSL_ST1	11
12				12
13				13
14	GND	0	GND	14
15	GND	0	GND	15
16	FIRST_RXD	3.3	FIRST_RXD	16
17	GET_UART	3.3	GET_UART	17
18	INT_EXT	3.3	INT_EXT	18
19	RXD_CARD	0	RXD_CARD	19
20	TXD_CARD	0	TXD_CARD	20
21	GPC5	0	GPC5	21
22	GPC4	0	GPC4	22
23	GPC3	0	GPC3	23
24	GPC2	0	GPC2	24
25	GPC1	0	GPC1	25
101	NC	0	NC	101
102	GND	0	GND	102
103	GND	0	GND	103
104	GND	0	GND	104
105	TXD_PDP	3.3	TXD_PDP	105
106	RXD_PDP	3.3	RXD_PDP	106
107	KEY_COMM_IN	3.3	KEY_COMM_IN	107
108	CB_MUTE	3.3	CB_MUTE	108
109	STL_LINK	3.3	STL_LINK	109
110	GND	0	GND	110
111	GND	0	GND	111
114	V+6.5V	6.8	V+6.5V	114
115	V+6.5V	6.8	V+6.5V	115
116	GND	0	GND	116
117	GND	0	GND	117
118	V+3VSTB	3.3	V+3VSTB	118
119	V+3VSTB	3.3	V+3VSTB	119
120	NC	0	NC	120
121	NC	0	NC	121
122	NC	0	NC	122
123	NC	0	NC	123
124	NC	0	NC	124
125	NC	0	NC	125

COMM SLOT ASSY

AUDIO AMP ASSY

AP1 (CN5002)		Voltage (V)	P6	
No.	Name		Name	No.
1	V+16R5	16.7	V+16R5	1
2	V+16R5	16.7	V+16R5	2
3	GNDP	0	GNDP	3
4	GNDP	0	GNDP	4
5	GNDP	0	GNDP	5
6	GNDP	0	GNDP	6

POWER SUPPLY ASSY

AUDIO AMP ASSY

AP3 (CN5003)		Voltage (V)	SP2 (CN9801)	
No.	Name		Name	No.
1	GND	0	GND	1
2	R+	5.3	R+	2
3	R-	5.2	R-	3
SP TERMINAL L ASSY				
SP1 (CN9702)				
4	STBGND	0	STBGND	1
5	TEMP3	0-3.3	TEMP3	2
6	V+3VDD	3.3	V+3VDD	3
7	GND	0	GND	4
8	L+	5.3	L+	5
9	L-	5.2	L-	6

SP TERMINAL R ASSY

KEY CONTROL ASSY

KY2 (CN9002)		Voltage (V)	KY3 (CN4801)	
No.	Name		Name	No.
1	D7	0/3.3	D7	1
2	D6	0/3.3	D6	2
3	D5	0/3.3	D5	3
4	G0	0/3.3	G0	4
5	G1	0/3.3	G1	5
6	G2	0/3.3	G2	6
7	G3	0/3.3	G3	7
8	GND	0	GND	8

SIDE KEY ASSY

COMM SLOT I/F ASSY

VIDEO SLOT I/F ASSY

CS3 (CN8903)		Voltage (V)	VS2 (CN8952)	
No.	Name		Name	No.
1	GND	0	GND	1
2	FIRST_RXD	3.3	FIRST_RXD	2
3	GET_UART	3.3	GET_UART	3
4	INT_EXT	3.3	INT_EXT	4
5	RXD_GU	0	RXD_GU	5
6	TXD_GU	0	TXD_GU	6
7	GPC5	0	GPC5	7
8	GPC4	0	GPC4	8
9	GPC3	0	GPC3	9
10	GPC2	0	GPC2	10
11	GPC1	0	GPC1	11

VIDEO SLOT I/F ASSY

VIDEO SLOT 1 and 2 ASSY

VS5 (CN8954)		Voltage (V)	CN7902	
No.	Name		Name	No.
43	GB1_IC1	0/3.3	GB1_IC1	43
44	GB2_IC1	0/3.3	GB2_IC1	44
45	GB3_IC1	0/3.3	GB3_IC1	45
46	GB4_IC1	0/3.3	GB4_IC1	46
47	GB5_IC1	0/3.3	GB5_IC1	47
48	GB6_IC1	0/3.3	GB6_IC1	48
49	GB7_IC1	0/3.3	GB7_IC1	49
50				50
51				51
52	GND	0	GND	52
53	GND	0	GND	53
54	BB0_IC1	0/3.3	BB0_IC1	54
55	BB1_IC1	0/3.3	BB1_IC1	55
56	BB2_IC1	0/3.3	BB2_IC1	56
57	BB3_IC1	0/3.3	BB3_IC1	57
58	BB4_IC1	0/3.3	BB4_IC1	58
59	BB5_IC1	0/3.3	BB5_IC1	59
60	BB6_IC1	0/3.3	BB6_IC1	60
61	BB7_IC1	0/3.3	BB7_IC1	61
62	GND	0	GND	62
63				63
64				64
65	GND	0	GND	65
66	GND	0	GND	66
67	KEY	3.3	KEY	67
68	NC	0	NC	68
69	TXD_CARD	0	TXD_CARD	69
70	RXD_CARD	0	RXD_CARD	70
71	INT_EXT	3.3	INT_EXT	71
72	NC	0	NC	72
73	EMGREQ1_V	0	EMGREQ1_V	73
74	EMGREQ2_V	0	EMGREQ2_V	74
75	IC1V_OE	3.3	IC1V_OE	75
76	RESETX1	3.3	RESETX1	76
77	NC	0	NC	77
78	SD_SEL	3.3	SD_SEL	78
79	FNC2	0	FNC2	79
80	FNC3	0	FNC3	80
81	SOUND1	3.3	SOUND1	81
82	GND	0	GND	82
83	DSUBR	3.8	DSUBR	83
84	GND	0	GND	84
85	DSUBG	0	DSUBG	85
86	GND	0	GND	86
87	DSUBB	3.8	DSUBB	87
88	GND	0	GND	88
89	IN5_HD	0	IN5_HD	89
90	SOUSA_X	3.3	SOUSA_X	90
91	GPC1	0	GPC1	91
92	GPC2	0	GPC2	92
93	GPC5	0	GPC5	93
94	VYOB1	0	VYOB1	94
95	VYOB2	0	VYOB2	95
96	DSUBSW_DET	0	DSUBSW_DET	96
101	GND	0	GND	101
102	GND	0	GND	102
103	GND	0	GND	103

VIDEO SLOT I/F ASSY

VIDEO SLOT 1 and 2 ASSY

VS5 (CN8954)		Voltage (V)	CN7902	
No.	Name		Name	No.
1	GND	0	GND	1
2	GND	0	GND	2
3	G_SLOT	0	G_SLOT	3
4	GND	0	GND	4
5	B_SLOT	0	B_SLOT	5
6	GND	0	GND	6
7	R_SLOT	0	R_SLOT	7
8	GND	0	GND	8
9	HD_SLOT	0	HD_SLOT	9
10	GND	0	GND	10
11	VD_SLOT	0	VD_SLOT	11
12	GND	0	GND	12
13	AUDIO_L_SLOT	6	AUDIO_L_SLOT	13
14	GND	0	GND	14
15	AUDIO_R_SLOT	6	AUDIO_R_SLOT	15
16	GND	0	GND	16
17	SLOT_ST1	0	SLOT_ST1	17
18	S_DIN_SEL	0	S_DIN_SEL	18
19	FNC_1	0	FNC_1	19
20	FNC_0	5	FNC_0	20
21	V+3.3V	3.2	V+3.3V	21
22	V+3.3V	3.2	V+3.3V	22
23	VD_DET	0	VD_DET	23
24	GND	0	GND	24
25	HD_DET	0	HD_DET	25
26	GND	0	GND	26
27	VD	3.2	VD	27
28	GND	0	GND	28
29	HD	3	HD	29
30	GND	0	GND	30
31	GND	0	GND	31
32	RB0_IC1	0/3.3	RB0_IC1	32
33	RB1_IC1	0/3.3	RB1_IC1	33
34	RB2_IC1	0/3.3	RB2_IC1	34
35	RB3_IC1	0/3.3	RB3_IC1	35
36	RB4_IC1	0/3.3	RB4_IC1	36
37	RB5_IC1	0/3.3	RB5_IC1	37
38	RB6_IC1	0/3.3	RB6_IC1	38
39	RB7_IC1	0/3.3	RB7_IC1	39
40	GND	0	GND	40
41	GND	0	GND	41
42	GB0_IC1	0/3.3	GB0_IC1	42

VIDEO SLOT I/F ASSY

VIDEO SLOT 1 and 2 ASSY

No.	VS5 (CN8954)		CN7902	
	Name	Voltage (V)	Name	No.
104	SCL_VS	3.1	SCL_VS	104
105	GND	0	GND	105
106	SDA_VS	3.1	SDA_VS	106
107	GND	0	GND	107
108	GND	0	GND	108
109	GND	0	GND	109
110	V+12V	12.9	V+12V	110
111	GND	0	GND	111
112	NC	0	NC	112
113	GND	0	GND	113
114	V+3.3STB	3.3	V+3.3STB	114
115	V+13.5	13.6	V+13.5	115
116	V+13.5	13.6	V+13.5	116
117	IN4_DET	0	IN4_DET	117
118	IN3_DET	0	IN3_DET	118
119	SLOT_ST2	3	SLOT_ST2	119
120	IR	5.1	IR	120
121	NC	0	NC	121
122	NC	0	NC	122
123	GND	0	GND	123
124	GND	0	GND	124
125	3G4G	3.3	3G4G	125
126	IN5_DET	0	IN5_DET	126
127	GND	0	GND	127
128	DE	2.5	DE	128
129	GND	0	GND	129
130	CLK	1.5	CLK	130
131	GND	0	GND	131
132	BA7_IC1	0/3.3	BA7_IC1	132
133	BA6_IC1	0/3.3	BA6_IC1	133
134	BA5_IC1	0/3.3	BA5_IC1	134
135	BA4_IC1	0/3.3	BA4_IC1	135
136	BA3_IC1	0/3.3	BA3_IC1	136
137	BA2_IC1	0/3.3	BA2_IC1	137
138	BA1_IC1	0/3.3	BA1_IC1	138
139	BA0_IC1	0/3.3	BA0_IC1	139
140	GND	0	GND	140
141	GND	0	GND	141
142	GA7_IC1	0/3.3	GA7_IC1	142
143	GA6_IC1	0/3.3	GA6_IC1	143
144	GA5_IC1	0/3.3	GA5_IC1	144
145	GA4_IC1	0/3.3	GA4_IC1	145
146	GA3_IC1	0/3.3	GA3_IC1	146
147	GA2_IC1	0/3.3	GA2_IC1	147
148	GA1_IC1	0/3.3	GA1_IC1	148
149	GA0_IC1	0/3.3	GA0_IC1	149
150				150
151				151
152	GND	0	GND	152
153	GND	0	GND	153
154	RA7_IC1	0/3.3	RA7_IC1	154
155	RA6_IC1	0/3.3	RA6_IC1	155
156	RA5_IC1	0/3.3	RA5_IC1	156
157	RA4_IC1	0/3.3	RA4_IC1	157
158	RA3_IC1	0/3.3	RA3_IC1	158
159	RA2_IC1	0/3.3	RA2_IC1	159
160	RA1_IC1	0/3.3	RA1_IC1	160

VIDEO SLOT I/F ASSY

VIDEO SLOT 1 and 2 ASSY

No.	VS5 (CN8954)		CN7902	
	Name	Voltage (V)	Name	No.
161	RA0_IC1	0/3.3	RA0_IC1	161
162	GND	0	GND	162
163				163
164				164
165	GND	0	GND	165
166	GND	0	GND	166
167	VSEPSCL	3.3	VSEPSCL	167
168	VSEPSDA	3.3	VSEPSDA	168
169	NC	0	NC	169
170	GET_UART	3.3	GET_UART	170
171	FIRST_RXD	3.3	FIRST_RXD	171
172	NC	0	NC	172
173	EMGREQ1_S	0	EMGREQ1_S	173
174	EMGREQ2_S	0	EMGREQ2_S	174
175	IC1S_OE	0	IC1S_OE	175
176	NC	0	NC	176
177	NC	0	NC	177
178	NC	0	NC	178
179	SLOT_ST3	0.4	SLOT_ST3	179
180	M_CHOICE	0	M_CHOICE	180
181	SOUND2	0	SOUND2	181
182	GND	0	GND	182
183	GND	0	GND	183
184	DSUBH	4.5	DSUBH	184
185	GND	0	GND	185
186	DSUBV	4.95	DSUBV	186
187	GND	0	GND	187
188	GND	0	GND	188
189	IN5_VD	3.3	IN5_VD	189
190	HYOUJI_X	0	HYOUJI_X	190
191	GPC3	0	GPC3	191
192	GPC4	0	GPC4	192
193	NC	0	NC	193
194	VYOB14	0	VYOB14	194
195	VYOB15	0	VYOB15	195
196	VYOB16	0	VYOB16	196

5. PCB PARTS LIST

NOTES: ● Parts marked by "NSP" are generally unavailable because they are not in our Master Spare Parts List.

● The Δ mark found on some component parts indicates the importance of the safety factor of the part. Therefore, when replacing, be sure to use parts of identical designation.

● When ordering resistors, first convert resistance values into code form as shown in the following examples.

Ex.1 When there are 2 effective digits (any digit apart from 0), such as 560 ohm and 47k ohm (tolerance is shown by J=5%, and K=10%).

560 Ω \rightarrow 56×10^1 \rightarrow 561 RD1/4PU $\overline{561}$ J
 47k Ω \rightarrow 47×10^3 \rightarrow 473 RD1/4PU $\overline{473}$ J
 0.5 Ω \rightarrow R50 RN2H $\overline{R50}$ K
 1 Ω \rightarrow 1R0 RS1P $\overline{1R0}$ K

Ex.2 When there are 3 effective digits (such as in high precision metal film resistors).

5.62k Ω \rightarrow 562×10^1 \rightarrow 5621 RN1/4PC $\overline{5621}$ F

LIST OF ASSEMBLIES for PDP-504CMX

LIST OF ASSEMBLIES for PDP-434CMX

NSP 1..50 ADDRESS ASSY AWW2080
 NSP 2..50 ADDRESS ASSY AWZ6870

NSP 1..43 ADDRESS ASSY AWW2076
 NSP 2..43 ADDRESS ASSY AWZ6862

NSP 1..50 SCAN ASSY AWW2083
 NSP 2..50 SCAN A ASSY AWZ6878
 NSP 2..50 SCAN B ASSY AWZ6879
 NSP 2..X CONNECTOR A ASSY AWZ6880
 NSP 2..X CONNECTOR B ASSY AWZ6881

NSP 1..43 SCAN ASSY AWW2079
 NSP 2..43 SCAN A ASSY AWZ6873
 NSP 2..43 SCAN B ASSY AWZ6874
 NSP 2..X CONNECTOR A ASSY AWZ6875
 NSP 2..X CONNECTOR B ASSY AWZ6876

NSP 1..50 X DRIVE ASSY AWW2175
 2..50 X DRIVE ASSY AWZ6877
 2..PANEL SENSOR ASSY AWZ6872

NSP 1..43 X DRIVE ASSY AWW2174
 2..43 X DRIVE ASSY AWZ6865
 2..PANEL SENSOR ASSY AWZ6872

1..50 Y DRIVE ASSY AWW2082

1..43 Y DRIVE ASSY AWW2078

NSP 1..RGB ASSY AWW2185
 2..RGB ASSY AWZ6992
 2..SIDE KEY ASSY AWZ6852

NSP 1..RGB ASSY AWW2185
 2..RGB ASSY AWZ6992
 2..SIDE KEY ASSY AWZ6852

NSP 1..CMX FUKUGO ASSY AWW2170
 2..AV I/O ASSY AWZ6847
 2..AUDIO AMP ASSY AWZ6848
 2..COMM SLOT ASSY AWZ6849
 2..COMM SLOT I/F ASSY AWZ6980
 2..VIDEO SLOT I/F ASSY AWZ6851
 2..KEY CONTROL ASSY AWZ6981
 2..LED OPT ASSY AWZ6957
 2..IR RECEIVE ASSY AWZ6989
 2..SP TERMINAL L ASSY AWZ6856
 2..SP TERMINAL R ASSY AWZ6857
 2..COVER ASSY AWZ6858
 2..AV I/O I/F ASSY AWZ6859

NSP 1..CMX FUKUGO ASSY AWW2172
 2..AV I/O ASSY AWZ6894
 2..AUDIO AMP ASSY AWZ6848
 2..COMM SLOT ASSY AWZ6849
 2..COMM SLOT I/F ASSY AWZ6980
 2..VIDEO SLOT I/F ASSY AWZ6851
 2..KEY CONTROL ASSY AWZ6981
 2..LED OPT ASSY AWZ6957
 2..IR RECEIVE ASSY AWZ6989
 2..SP TERMINAL L ASSY AWZ6856
 2..SP TERMINAL R ASSY AWZ6857
 2..COVER ASSY AWZ6858
 2..AV I/O I/F ASSY AWZ6859

1..DIGITAL VIDEO ASSY AWW2169

1..DIGITAL VIDEO ASSY AWW2169

Δ 1..POWER SUPPLY UNIT AXY1083

Δ 1..POWER SUPPLY UNIT AXY1083

<u>Mark No.</u>	<u>Description</u>	<u>Part No.</u>
50 ADDRESS ASSY		
[50 ADR LOGIC BLOCK]		
<u>SEMICONDUCTORS</u>		
IC1501		PEE001B
<u>COILS AND FILTERS</u>		
L1504		QTL1013
<u>CAPACITORS</u>		
C1501, C1502 (47/6.3V)		ACH1357
C1509, C1510		CKSSYB102K50
C1503-C1507, C1511, C1512, C1552		CKSSYF104Z16
C1555, C1558, C1561, C1564		CKSSYF104Z16
<u>RESISTORS</u>		
R1510, R1519, R1522, R1526		RAB4C470J
R1505-R1509, R1530, R1531		RS1/16SS1000F
R1511-R1518, R1520, R1521		RS1/16SS470J
R1523, R1524, R1527, R1528		RS1/16SS470J
R1532-R1535		RS1/16SS470J
Other Resistors		RS1/16S###J
<u>OTHERS</u>		
CN1501 40P FFC CONNECTER		AKM1215
[50 ADR RESONANCE BLOCK]		
<u>SEMICONDUCTORS</u>		
IC1601-IC1603		TND307TD
Q1604		2SA1163
Q1601		HAT1110R
Q1602, Q1603		HAT3021R
D1601		1SS302
D1605, D1606, D1616, D1617		D1FL20U(S)
D1610, D1619		RF051UA1D
D1602, D1607, D1615		UDZS15(B)
<u>COILS</u>		
L1601, L1602		ATH1164
<u>CAPACITORS</u>		
C1605 (0.01/100V)		ACG1101
C1619, C1620 (330P/100V)		ACG1105
C1609, C1615 (0.1/100V)		ACG1119
C1618		ACH1357
C1603 (47/16V)		ACH1391
C1601, C1602 (56/80V)		ACH1405
C1608, C1614		CKSRYB104K25
C1604, C1606, C1612		CKSSYF104Z16
<u>RESISTORS</u>		
R1631		ACN1174
R1602, R1614, R1615, R1622, R1623		RS1/16SS220J
Other Resistors		RS1/16S###J
50 Y DRIVE ASSY		
[50 Y LOGIC BLOCK]		
<u>SEMICONDUCTORS</u>		
IC2002		TC74ACT540FT
IC2001, IC2003		TC74ACT541FT
IC2005, IC2006		TC74VHC08FT

<u>Mark No.</u>	<u>Description</u>	<u>Part No.</u>
IC2004		TC74VHC541FT
<u>CAPACITORS</u>		
C2001		CEHAT470M16
C2007		CKSRYB471K50
C2002-C2006, C2008		CKSSYB104K10
<u>RESISTORS</u>		
R2045		RAB4C0R0J
R2055		RAB4C100J
R2025		RAB4C101J
R2018, R2019		RAB4C102J
R2002, R2004, R2013-R2015		RAB4C470J
R2005, R2006, R2012, R2016, R2017		RAB4C472J
Other Resistors		RS1/16S###J
<u>OTHERS</u>		
CN2001 50P CONNECTER		AKM1201
[50 Y SCAN BLOCK]		
<u>SEMICONDUCTORS</u>		
IC2101, IC2103-IC2106, IC2108, IC2109		HCPL-M611
IC2111, IC2112		PST3638UR
IC2102, IC2107		TC74ACT540FT
<u>COILS AND FILTERS</u>		
L2101-L2103		LFEA100J
<u>CAPACITORS</u>		
C2104, C2111		ACH1413
C2101, C2107, C2113		CEHAT221M16
C2118, C2119		CKSRYB102K50
C2116, C2117		CKSRYB471K50
C2102, C2103, C2105, C2106		CKSSYB104K10
C2108-C2110, C2112, C2114		CKSSYB104K10
<u>RESISTORS</u>		
R2138, R2141		RAB4C0R0J
R2121, R2128		RAB4C472J
Other Resistors		RS1/16S###J
<u>OTHERS</u>		
CN2101, CN2102 15P CONNECTER		AKM1200
[50 Y RESONANCE BLOCK]		
<u>SEMICONDUCTORS</u>		
IC2211		BA10393F
IC2201, IC2202		TND506MD
Q2213		2SC4081
Q2205, Q2206, Q2208, Q2209		2SK3555-01MR
Q2202, Q2203, Q2212		2SK3592-01S
Q2201, Q2204, Q2207, Q2210		QSZ2
D2209, D2223		1SS302
D2228, D2229, D2232, D2233		1SS355
D2202-D2205, D2207, D2208		D1FL40
D2212-D2214, D2216-D2219		D1FL40
D2221, D2222		D1FL40
D2201, D2206, D2211, D2220, D2225		RF2001T3D
D2230		RF2001T3D
D2210, D2224		UDZS16(B)

Mark No. Description**Part No.****Mark No. Description****Part No.****COILS**

L2203, L2205	ATH1119
L2202	ATH1155
L2204	ATH1156
L2201	LFEA470J

CAPACITORS

C2309-C2311, C2327, C2329, C2330	ACE1163
C2314	ACE1165
C2346 (0.33/100V)	ACG1118
C2336	ACH1393
C2316, C2331	ACH1415
C2303, C2342	ACH1416
C2343	CCSRCH102J50
C2306	CEHAT221M25
C2308, C2324, C2339, C2340, C2349	CEHAT470M16
C2304, C2320, C2338, C2348	CEHAT470M25
C2305, C2322, C2323, C2325, C2341	CKSRYB104K16
C2347	CKSRYB105K6R3
C2301, C2307, C2344	CKSRYF104Z50

CAPACITORS

C2212-C2214, C2226, C2227	ACE1175
C2211, C2224 (100P/630V)	ACG1104
C2210, C2223 (0.22/250V)	ACG1112
C2238, C2240 (150P/630V)	ACG1120
C2202, C2205, C2216, C2217	CCSRCH331J50

C2236	CEHAT2R2M50
C2203, C2218	CKSRYB105K6R3
C2230, C2232, C2233, C2235	CKSSYB104K10
C2201, C2208, C2215, C2219	CKSYB105K25

RESISTORS

R2240, R2241	RS1/10S1003F
R2244-R2247	RS1/10S100J
R2260, R2261	RS1/10S220J
R2205, R2211, R2213, R2220, R2221	RS1/10S2R2J
R2253, R2265	RS1/10S2R2J

R2234	RS1/16S1202F
R2235	RS1/16S3301F
R2233	RS1/16S5601F
R2242	RS1/16S8201F
R2215, R2230	RS1MMF101J

R2256, R2259	RS2MMF220J
VR2201-VR2204	CCP1390
Other Resistors	RS1/16S###J

OTHERS

KN2301-KN2305, KN2310, KN2312	ANK-142
KN2314, KN2316 GROUND PLATE	ANK-142
CN2301 CONNECTOR	B11B-EH

OTHERS

2201 DRIVE HEATSINK	ANH1628
2201 SCREW	PMH30P080FTC

[50 Y D-D CON BLOCK]**SEMICONDUCTORS**

IC2406	BA10358F
IC2401	MIP2E3DMC
IC2402-IC2405, IC2407, IC2409	PS2701A-1(L)
IC2410-IC2412	TA76431FR
Q2402, Q2407	2SA1037K

Q2410	2SA1163
Q2417	2SA2005
Q2405	2SC2713
Q2411-Q2413, Q2416, Q2419	2SC4081
Q2403	2SD1664

Q2401, Q2404	2SD1898
Q2415	HN1C01FU
D2430	1SS301
D2410, D2419, D2436	1SS302
D2409, D2418	1SS355

D2402	D1FK70
D2404-D2407	D1FL20U(S)
D2414	D1FL40
D2403	EC8FS6
D2401	U1ZB330

D2412, D2413, D2422	UDZS15(B)
D2437, D2438	UDZS33(B)
D2432	UDZS4R3(B)
D2423, D2431	UDZS5R6(B)

COILS AND FILTERS

T2402	ATK1156
T2403	ATK1157
T2401	ATK1158

COILS AND FILTERS

L2306, L2307	ATH1112
L2304, L2309	LFEA100J
L2308	LFEA101J
L2301, L2302, L2305	LFEA470J

Mark No.	Description	Part No.
L2402		LFEA100J
L2401		LFEA101J
L2403		LFEA470J

CAPACITORS

C2406	ACH1360
C2401	ACH1361
C2427	CEHAT100M50
C2403	CEHAT101M16
C2405, C2407, C2417	CEHAT101M25
C2414	CEHAT221M16
C2410	CEHAT221M25
C2411	CEHAT331M25
C2420	CEHAT470M2A
C2409, C2419	CKSRYB103K50
C2402, C2412, C2413, C2423, C2425	CKSRYB104K16
C2434-C2436, C2441-C2444	CKSRYB104K16
C2415, C2421, C2428	CKSRYB105K6R3
C2404, C2408, C2416, C2418, C2426	CKSRYF104Z50
C2429	CKSRYF104Z50

RESISTORS

R2429	ACN1225
R2435, R2439	RS1/10S2202F
R2402-R2404	RS1/10S3902F
R2442	RS1/16S1201F
R2468	RS1/16S1202F
R2424	RS1/16S2001F
R2420, R2427, R2438	RS1/16S2201F
R2451	RS1/16S2202F
R2467	RS1/16S3301F
R2452, R2453	RS1/16S3302F
R2457-R2460	RS1/16S4701F
R2506	RS3LMF151J
VR2401, VR2402	CCP1390
Other Resistors	RS1/16S###J
2401 HEATSINK	ANH1614
2401 SCREW	BBZ30P080FTC

RESISTORS

Other Resistors	RS1/16S###J
-----------------	-------------

50 SCAN A ASSY

SEMICONDUCTORS

IC3001-IC3006	AN16021AA-K
D3003-D3006	1SS355

CAPACITORS

C3001, C3002, C3012 (0.1/250V)	ACG1088
C3013, C3023, C3024 (0.1/250V)	ACG1088
C3034, C3035, C3045 (0.1/250V)	ACG1088
C3046, C3056, C3057 (0.1/250V)	ACG1088
C3005, C3008, C3016, C3019, C3026	CCSRCH101J50
C3029, C3037, C3040, C3048, C3051	CCSRCH101J50
C3060, C3063	CCSRCH101J50
C3007, C3018, C3033, C3044, C3050	CCSRCH181J50
C3062	CCSRCH181J50
C3006, C3011, C3017, C3022	CCSRCH331J50

Mark No.	Description	Part No.
C3031, C3032, C3042, C3043, C3049		CCSRCH331J50
C3055, C3061, C3066		CCSRCH331J50
C3009, C3010, C3020, C3021, C3028		CCSRCH390J50
C3030, C3039, C3041, C3053, C3054		CCSRCH390J50
C3064, C3065		CCSRCH390J50
C3003, C3014, C3025, C3036, C3047		CKSRYB105K6R3
C3058		CKSRYB105K6R3

RESISTORS

R3003, R3011, R3017, R3025, R3030	RAB4C221J
R3036	RAB4C221J
Other Resistors	RS1/16S###J

OTHERS

CN3001 13P CONNECTER NONPB	AKP1261
K3001, K3004, K3009, K3015, K3017	AKX9002
K3019, K3021 TEST PIN	AKX9002

50 SCAN B ASSY

SEMICONDUCTORS

IC3201-IC3206	AN16021AA-K
D3203-D3206	1SS355

CAPACITORS

C3201, C3211, C3212 (0.1/250V)	ACG1088
C3222, C3223, C3233 (0.1/250V)	ACG1088
C3234, C3244, C3245 (0.1/250V)	ACG1088
C3255, C3256, C3266 (0.1/250V)	ACG1088
C3203, C3204, C3214, C3215, C3226	CCSRCH101J50
C3228, C3237, C3239, C3247, C3251	CCSRCH101J50
C3258, C3259	CCSRCH101J50
C3206, C3217, C3232, C3243, C3249	CCSRCH181J50
C3261	CCSRCH181J50
C3205, C3210, C3216, C3221	CCSRCH331J50
C3230, C3231, C3241, C3242, C3248	CCSRCH331J50
C3254, C3260, C3265	CCSRCH331J50
C3208, C3209, C3219, C3220, C3227	CCSRCH390J50
C3229, C3238, C3240, C3252, C3253	CCSRCH390J50
C3263, C3264	CCSRCH390J50
C3202, C3213, C3224, C3235, C3246	CKSRYB105K6R3
C3257	CKSRYB105K6R3

RESISTORS

R3202, R3210, R3216, R3224, R3229	RAB4C221J
R3235	RAB4C221J
Other Resistors	RS1/16S###J

OTHERS

CN3201 13P CONNECTER NONPB	AKP1261
K3203, K3208, K3214, K3216, K3218	AKX9002
K3221 TEST PIN	AKX9002

AV I/O ASSY

[AV I/O ASSY] SEMICONDUCTORS

IC7609	24LCS21A
IC7610, IC7613	AN5870SB
IC7602, IC7605-IC7607	BA4558F-HT
IC7603	BD3869AF
⚠ IC7604	NJM78L09UA

Mark No. Description**Part No.**

IC7601, IC7608
IC7612
IC7611
A Q7602, Q7605, Q7702
Q7603

Q7604, Q7606-Q7608
Q7701
Q7601
Q7609
D7601

TC4052BFT
TC74AC04FT
TC74VHCT541AFT
2SC4116
DTA124EUA

DTC124EUA
HN1C01FU
RN1902
SM6K2
1SS301

D7606-D7608, D7610, D7611
D7613, D7614, D7616, D7617
D7619, D7701
D7602, D7603, D7605, D7609
B D7604

1SS302
1SS302
1SS355
UDZS5.6B
UDZS6.8B

CAPACITORS

C7633, C7634
C7673, C7674
C7631, C7632
C7611, C7612
C7722

CCSRCH101J50
CCSRCH220J50
CCSRCH221J50
CCSRCH471J50
CEHAT100M50

C7654
C7665
C7623, C7648
C7705
C7714, C7716, C7718

CEHAT101M10
CEHAT101M16
CEHAT220M50
CEHAT221M6R3
CEHAT331M10

C7619, C7635, C7637, C7695, C7697
C7721
C7681, C7686, C7690
C7601, C7602, C7609, C7610, C7614
C7616, C7638, C7639, C7643, C7653

CEHAT470M16
CEHAT470M16
CEHAT471M16
CKSQYB225K10
CKSQYB225K10

C7627-C7630, C7640, C7650
C7642, C7652, C7660, C7661, C7666
C7676, C7680, C7685, C7689
C7698-C7703, C7707, C7712, C7713
C7715, C7717

CKSRYB102K50
CKSRYB103K50
CKSRYB103K50
CKSRYB103K50
CKSRYB103K50

C7621, C7622
C7603, C7620, C7662, C7663, C7667
C7675, C7677, C7678, C7684
C7693, C7694, C7723
C7641, C7651

CKSRYB104K16
CKSRYB105K10
CKSRYB105K10
CKSRYB105K10
CKSRYB222K50

C7646, C7656
C7617, C7618, C7624-C7626, C7636
C7644, C7647, C7649, C7655, C7664
C7668, C7679, C7682, C7683, C7687
C7691, C7692, C7696, C7704, C7706

CKSRYB471K50
CKSSYF104Z16
CKSSYF104Z16
CKSSYF104Z16
CKSSYF104Z16

E C7708-C7711, C7720

CKSSYF104Z16

RESISTORS

R7751-R7753
R7712, R7725
R7699-R7701, R7741-R7743
R7653, R7654, R7673, R7674
R7709-R7711

RS1/16S2200F
RS1/16S2201F
RS1/16S27R0F
RS1/16S3301F
RS1/16S75R0F

Other Resistors

RS1/16S###J

OTHERS

F CN7602, CN7603 JACK
JA7606, JA7607 15P D-SUB SOCKET
CN7601 PLUG(15P)

AKN1069
AKP1241
KM200NA15

Mark No. Description**Part No.****[IF UCOM BLOCK]
SEMICONDUCTORS**

IC8705
IC8702
IC8703
IC8701
IC8704

24LC01B
HD64F3687FP
PST9230N
TC74VHC08FT
TC7W126FU

Q8701
Q8708
Q8702

2SJ461A
DTA124EUA
DTC124EUA

COILS AND FILTERS

L8702

LCTAWR68J2520

CAPACITORS

C8706, C8707
C8708, C8714
C8704, C8718
C8717, C8720
C8722-C8724

CCSRCH120J50
CEHAT470M16
CEHAT471M6R3
CKSRYB103K50
CKSRYB471K50

C8709
C8701-C8703, C8705, C8711-C8713
C8715, C8716, C8719, C8721, C8725

CKSRYB472K50
CKSSYF104Z16
CKSSYF104Z16

RESISTORS

R8719, R8720, R8723, R8724, R8726
R8702, R8704, R8745
R8736
Other Resistors

RAB4C101J
RAB4C103J
RS1/16S1302F
RS1/16S###J

OTHERS

CN8701 PLUG 8-P
K8701-K8703 TEST PIN
X8702 CERAMIC RESONATOR
X8701 CRYSTAL OSCILLATOR
CN8704 PLUG(6P)

AKM1225
AKX9002
ASS1168
ASS1172
KM200NA6

**[DVI BLOCK]
SEMICONDUCTORS**

IC7502
IC7511
IC7503
IC7504-IC7510
Q7503

24LCS21A
BD6522F
SII1161CTU-K
TC74LCX541FT
DTA124EUA

Q7501, Q7502
D7501
D7503, D7504
D7502

DTC124EUA
1SS301
1SS302
UDZS6.8B

CAPACITORS

C7524, C7526, C7530, C7532
C7534, C7535, C7537, C7538
C7541, C7542, C7546, C7548-C7550
C7504, C7507
C7528, C7578, C7579

CCSRCH101J50
CCSRCH101J50
CCSRCH101J50
CCSRCH221J50
CEHAT101M10

C7522
C7502, C7510, C7516, C7518
C7503, C7506
C7514, C7520, C7573-C7577
C7501, C7509, C7513, C7515, C7517

CEHAT221M6R3
CEHAT470M16
CKSRYB222K50
CKSRYB471K50
CKSSYF104Z16

C7519, C7521, C7523, C7525, C7527
C7529, C7531, C7533, C7536
C7539, C7540, C7543-C7545, C7547

CKSSYF104Z16
CKSSYF104Z16
CKSSYF104Z16

5	6	
Mark No.	Description	Part No.
C7551-C7559	CKSSYF104Z16	
RESISTORS		
R7560-R7565, R7568-R7573 R7524-R7529, R7536, R7540 R7552-R7555 R7578-R7590 R7538	RAB4CQ0R0J RAB4CQ100J RAB4CQ100J RAB4CQ470J RS1/16S3900F	
Other Resistors	RS1/16S###J	

OTHERS

CN7501 JACK	AKN1069
CN7503 DVI SOCKET (24P)	AKP1216

50 X DRIVE ASSY

OTHERS

1001 DRIVE SIRICON SHEET	AEH1062
1001 PLATE X	ANG2664
1001 DRIVE HEATSINK A	ANH1613
1001 SCREW	BMZ30P080FTC
1002 SCREW	PMB30P060FNI

[50 X LOGIC BLOCK]

SEMICONDUCTORS

IC1002	TC74ACT540FT
IC1001	TC74ACT541FT
IC1003	TC74VHC08FT

CAPACITORS

C1001	CEHAT470M25
C1002-C1004	CKSSYB104K10

RESISTORS

R1001, R1002, R1005	RAB4C470J
R1003, R1004, R1007	RAB4C472J
Other Resistors	RS1/16S###J

OTHERS

CN1001 30P FFC CONNECTER	AKM1218
--------------------------	---------

[50 X RESONANCE BLOCK]

SEMICONDUCTORS

IC1103	BA10393F
IC1101, IC1102	TND506MD
Q1113	2SC4116
Q1102, Q1103, Q1111, Q1112	2SK3555-01MR
Q1105, Q1108, Q1109	2SK3592-01S

Q1101, Q1104, Q1107, Q1110	QSZ2
D1109, D1122	1SS302
D1112, D1119, D1135, D1136	1SS355
D1101, D1102, D1104, D1105	D1FL40
D1107, D1108, D1111, D1114-D1117	D1FL40

D1120, D1121, D1127, D1128	D1FL40
D1103, D1113, D1118, D1125	RF2001T3D
D1129, D1130	RF2001T3D
D1110, D1123	UDZS16(B)

COILS AND FILTERS

L1103, L1105	ATH1119
L1104	ATH1155
L1102	ATH1156
L1101	LFEA470J

7	8	
Mark No.	Description	Part No.
CAPACITORS		
C1112, C1113, C1125-C1127	ACE1175	
C1111, C1124 (100P/630V)	ACG1104	
C1109, C1119 (0.22/250V)	ACG1112	
C1134, C1135 (150P/630V)	ACG1120	
C1101, C1105, C1116, C1117	CCSRCH331J50	
C1136	CEHAT2R2M50	
C1102, C1118	CKSRYB105K6R3	
C1128, C1130-C1132	CKSSYB104K10	
C1104, C1108, C1115, C1122	CKSYB105K25	

RESISTORS

R1116, R1122	RS1/10S1003F
R1133, R1143-R1145	RS1/10S100J
R1155, R1156	RS1/10S220J
R1103, R1106, R1118, R1119, R1123	RS1/10S2R2J
R1126, R1153	RS1/10S2R2J

R1136	RS1/16S1202F
R1139	RS1/16S3301F
R1130	RS1/16S5601F
R1134	RS1/16S8201F
R1113, R1128	RS1MMF101J

R1147, R1148	RS2MMF220J
VR1101-VR1104	CCP1390
Other Resistors	RS1/16S###J

OTHERS

1101 DRIVE HEATSINK	ANH1628
1101 SCREW	PMH30P080FTC

[50 X SUS BLOCK]
SEMICONDUCTORS

IC1202	HCPL-M611
IC1205	NJM2872F05
IC1203, IC1207	STK795-512A
IC1206	TND301S
IC1204, IC1209	TND307TD

Q1209	2SA1727
Q1203	2SD1898
Q1205	2SK2865
Q1208	DTC124EUA
Q1201	HN1B04FU

D1212	1SS302
D1211, D1213	1SS355
D1204, D1217	D1FL40
D1201, D1207	EC10QS04
D1208	UDZS5R6(B)

COILS AND FILTERS

L1204, L1205	ATH1112
L1202, L1207	LFEA100J
L1203, L1206	LFEA470J

CAPACITORS

C1214-C1216, C1228-C1230	ACE1163
C1245	ACE1173
C1209 (0.1/630V)	ACG1092
C1219, C1231	ACH1415
C1246	CEHAT221M25

C1201, C1203, C1207, C1220	CEHAT470M25
C1223, C1224, C1238, C1239, C1248	CEHAT470M25
C1212, C1213, C1225, C1240, C1241	CKSRYB104K16

Mark No. Description

C1243
C1202, C1205, C1206, C1247

Part No.

CKSRYB104K16
CKSRYF104Z50

Mark No. Description**RESISTORS**

R1073, R1074
R1075
R1071
R1072
Other Resistors

Part No.

RS1/16S1001F
RS1/16SS102J
RS1/16SS471J
RS1/16SS473J
RS1/16S###J

A RESISTORS

R1230
R1208, R1260, R1261
R1255
R1256
R1226, R1251

ACN1166
ACN1174
ACN1178
ACN1198
RS1MMF331J

R1235, R1236
Other Resistors

RS2MMF121J
RS1/16S###J

X CONNECTOR A ASSY

This assembly has no service parts.

OTHERS

KN1201-KN1205, KN1208, KN1210
KN1211, K1212, KN1214
GROUND PLATE
CN1201 CONNECTOR

ANK-142
ANK-142

B12B-EH

X CONNECTOR B ASSY

This assembly has no service parts.

[50 X D-D CON BLOCK]**SEMICONDUCTORS**

IC1402
IC1401, IC1403
IC1404
Q1401
Q1402

MIP2E3DMU
PS2701A-1(L)
TA76431FR
2SA1576A
2SC4116

C D1406, D1409, D1410
D1407, D1408
D1405
D1401, D1403

D1FK70
D1FL20U(S)
U1ZB330
UDZS5R6(B)

COILS AND FILTERS

T1401
L1401

ATK1153
LFEA101J

CAPACITORS

C1401, C1402
C1404
C1405
C1409
C1403, C1407, C1408, C1411

ACH1361
CEHAT101M16
CEHAT101M25
CEHAT331M16
CKSRYB104K16

C1406

CKSRYF104Z50

RESISTORS

R1405, R1406, R1408-R1410, R1414
R1420
R1403
R1401, R1404
R1417

RS1/10S3602F
RS1/16S1101F
RS1/16S2702F
RS1/16S4701F
RS1/16S7500F

E VR1401
Other Resistors

CCP1390
RS1/16S###J

PANEL SENSOR ASSY**SEMICONDUCTORS**

IC1072
IC1071

MM1522XU
MM3012XN

CAPACITORS

C1071, C1074, C1075
C1072, C1073

CKSRYB103K50
CKSRYF105Z10

F

Mark No.	Description	Part No.
43 ADDRESS ASSY		
[43 ADR LOGIC BLOCK]		
SEMICONDUCTORS		
IC1501		PEE001B
COILS AND FILTERS		
L1504		QTL1013
CAPACITORS		
C1501, C1502 (47/6.3V)		ACH1357
C1509, C1510		CKSSYB102K50
C1503-C1507, C1555, C1558, C1561		CKSSYF104Z16
C1564		CKSSYF104Z16
RESISTORS		
R1510, R1519, R1522		RAB4C470J
R1505-R1509, R1530, R1531		RS1/16SS1000F
R1511-R1518, R1520-R1521		RS1/16SS470J
R1523-R1524		RS1/16SS470J
R1536-R1539		RS1/16SS470J
Other Resistors		RS1/16S###J
OTHERS		
CN1501 40P FFC CONNECTER		AKM1215
[43 ADR RESONANCE BLOCK]		
SEMICONDUCTORS		
IC1601-IC1603		TND307TD
Q1604		2SA1163
Q1601		HAT1110R
Q1602, Q1603		HAT3021R
D1601		1SS302
D1605-D1608		RF051UA1D
D1602-D1604		UDZS15(B)
COILS AND FILTERS		
L1601, L1602		ATH1163
CAPACITORS		
C1605 (0.1/100V)		ACG1098
C1607, C1615 (0.1/100V)		ACG1121
C1613 (47/6.3V)		ACH1357
C1603 (47/16V)		ACH1391
C1601, C1602 (56/80V)		ACH1405
C1609, C1614		CKSRYB104K25
C1604, C1608, C1612		CKSSYF104Z16
RESISTORS		
R1620 (10, 1/2W)		ACN1174
R1602, R1608-R1611		RS1/16SS220J
Other Resistors		RS1/16S###J
43 Y DRIVE ASSY		
[43 Y LOGIC BLOCK]		
SEMICONDUCTORS		
IC2002		TC74ACT540FT
IC2001, IC2003		TC74ACT541FT
IC2005, IC2006		TC74VHC08FT
IC2004		TC74VHC541FT

Mark No.	Description	Part No.
CAPACITORS		
C2001		CEHAT470M16
C2007		CKSRYB471K50
C2002-C2006, C2008		CKSSYB104K10
RESISTORS		
R2045		RAB4C0R0J
R2055		RAB4C100J
R2025		RAB4C101J
R2018, R2019		RAB4C102J
R2002, R2004, R2013-R2015		RAB4C470J
R2005, R2006, R2012, R2016, R2017		RAB4C472J
Other Resistors		RS1/16S###J
OTHERS		
CN2001 50P CONNECTER		AKM1201
[43 Y SCAN BLOCK]		
SEMICONDUCTORS		
IC2101, IC2103-IC2106, IC2108, IC2109		HCPL-M611
IC2111, IC2112		PST3638UR
IC2102, IC2107		TC74ACT540FT
COILS AND FILTERS		
L2101-L2103		LFEA100J
CAPACITORS		
C2104, C2111		ACH1406
C2101, C2107, C2113		CEHAT221M16
C2118, C2119		CKSRYB102K50
C2116, C2117		CKSRYB471K50
C2102, C2103, C2105, C2106		CKSSYB104K10
C2108-C2110, C2112, C2114		CKSSYB104K10
RESISTORS		
R2138, R2141		RAB4C0R0J
R2121, R2128		RAB4C472J
Other Resistors		RS1/16S###J
OTHERS		
CN2101, CN2102 15P CONNECTER		AKM1200
[43 Y RESONANCE BLOCK]		
SEMICONDUCTORS		
IC2211		BA10393F
IC2201, IC2202		TND506MD
Q2213		2SC4081
Q2205, Q2206, Q2208, Q2209		2SK3555-01MR
Q2212		2SK3592-01S
Q2202, Q2203		2SK3864
Q2201, Q2204, Q2207, Q2210		QSZ2
D2209, D2223		1SS302
D2228, D2229, D2232, D2233		1SS355
D2202-D2205, D2207, D2208		D1FL40
D2212-D2214, D2216-D2219		D1FL40
D2221, D2222		D1FL40
D2201, D2206, D2211, D2220, D2225		RF2001T3D
D2230		RF2001T3D
D2210, D2224		UDZS16(B)
COILS AND FILTERS		
L2202		ATH1119
L2204		ATH1133

Mark No. Description**Part No.**L2203, L2205
L2201ATH1134
LFEA470J**Mark No. Description****Part No.**C2336
C2316, C2331ACH1407
ACH1414**A CAPACITORS**C2212-C2214, C2226, C2227
C2211, C2224, C2238 (100P/630V)
C2240 (0.22/250V)
C2210, C2223 (0.22/250V)
C2202, C2205, C2216, C2217ACE1168
ACG1104
ACG1104
ACG1112
CCSRCH331J50C2303, C2342
C2343
C2306
C2308, C2324, C2339, C2340, C2349
C2304, C2320, C2338, C2348ACH1416
CCSRCH102J50
CEHAT221M25
CEHAT470M16
CEHAT470M25C2203, C2218
C2230, C2232, C2233, C2235
C2201, C2208, C2215, C2219CKSRYB105K6R3
CKSSYB104K10
CKSYB105K25C2305, C2322, C2323, C2325, C2341
C2347
C2301, C2307, C2344CKSRYB104K16
CKSRYB105K6R3
CKSRYF104Z50**RESISTORS**R2240, R2241
R2244-R2247
R2260, R2261
R2205, R2211, R2213, R2220, R2221
R2253, R2265RS1/10S1003F
RS1/10S100J
RS1/10S220J
RS1/10S2R2J
RS1/10S2R2JR2234
R2235
R2233, R2242
R2215, R2230
R2256, R2259RS1/16S1002F
RS1/16S4701F
RS1/16S8201F
RS1MMF101J
RS2MMF5R6JVR2201-VR2204
Other ResistorsCCP1390
RS1/16S###J**RESISTORS**R2364, R2365
R2332
R2367, R2379-R2386
R2368
R2309ACN1162
ACN1166
RS1/10S0R0J
RS1/10S151J
RS1MMF132JR2310, R2311
R2312, R2313, R2322, R2325
R2348, R2352, R2358, R2359
Other ResistorsRS1MMF472J
RS3LMF100J
RS3LMF1R8J
RS1/16S###J**OTHERS**KN2301-KN2305, KN2310, KN2312
KN2314, KN2316 GROUND PLATE
CN2301 CONNECTORANK-142
ANK-142
B11B-EH**OTHERS**2201 DRIVE HEATSINK
2201 SCREWANH1628
PMH30P080FTC**[43 Y D-D CON BLOCK]
SEMICONDUCTORS**IC2406
IC2401
IC2402-IC2405, IC2407, IC2409
IC2410-IC2412
Q2402, Q2407BA10358F
MIP2E3DMC
PS2701A-1(L)
TA76431FR
2SA1037K**[43 Y SUS BLOCK]
SEMICONDUCTORS**IC2302
IC2305
IC2303, IC2307
IC2310
IC2301, IC2304HCPL-M611
NJM2872F05
STK795-511
TC7SH04FU
TND301SQ2410
Q2417
Q2405
Q2411-Q2413, Q2416, Q2419
Q24032SA1163
2SA2005
2SC2713
2SC4081
2SD1664IC2311
Q2313
Q2310
Q2303
Q2302TND307TD
2SA1727
2SC4081
2SD1898
2SK3325-ZQ2401, Q2404
Q2415
D2430
D2410, D2419, D2436
D2409, D24182SD1898
HN1C01FU
1SS301
1SS302
1SS355Q2312
Q2309
D2322
D2301, D2302, D2312, D2325
D23242SK3694-01S
HN1B04FU
1SS302
1SS355
D1FL40D2402
D2404-D2407
D2414
D2403
D2401D1FK70
D1FL20U(S)
D1FL40
EC8FS6
U1ZB330D2319
D2320
D2323
D2306EC10QS04
RF051UA1D
UDZS16(B)
UDZS5R6(B)D2412, D2413, D2422
D2437, D2438
D2432
D2423, D2431UDZS15(B)
UDZS33(B)
UDZS4R3(B)
UDZS5R6(B)**COILS AND FILTERS**L2306, L2307
L2304, L2309
L2308
L2301, L2302, L2305ATH1112
LFEA100J
LFEA101J
LFEA470J**COILS AND FILTERS**T2402
T2403
T2401
L2402
L2401ATK1156
ATK1157
ATK1158
LFEA100J
LFEA101J**F CAPACITORS**C2309-C2311, C2327, C2329, C2330
C2314
C2346 (0.33/100V)ACE1163
ACE1165
ACG1118

L2403

LFEA470J

5	6	
Mark No.	Description	Part No.
CAPACITORS		
C2406	ACH1360	ACH1360
C2401	ACH1361	ACH1361
C2427	CEHAT100M50	CEHAT100M50
C2403	CEHAT101M16	CEHAT101M16
C2405, C2407, C2417	CEHAT101M25	CEHAT101M25
C2414	CEHAT221M16	CEHAT221M16
C2410	CEHAT221M25	CEHAT221M25
C2411	CEHAT331M25	CEHAT331M25
C2420	CEHAT470M2A	CEHAT470M2A
C2409, C2419	CKSRYB103K50	CKSRYB103K50
C2402, C2412, C2413, C2423, C2425	CKSRYB104K16	CKSRYB104K16
C2434-C2436, C2441-C2444	CKSRYB104K16	CKSRYB104K16
C2415, C2421, C2428	CKSRYB105K6R3	CKSRYB105K6R3
C2404, C2408, C2416, C2418, C2426	CKSRYF104Z50	CKSRYF104Z50
C2429	CKSRYF104Z50	CKSRYF104Z50

RESISTORS

R2429	ACN1225	ACN1225
R2435, R2439	RS1/10S2202F	RS1/10S2202F
R2402-R2404	RS1/10S3902F	RS1/10S3902F
R2442	RS1/16S1201F	RS1/16S1201F
R2468	RS1/16S1202F	RS1/16S1202F
R2424, R2427	RS1/16S2001F	RS1/16S2001F
R2420, R2438	RS1/16S2201F	RS1/16S2201F
R2451	RS1/16S2202F	RS1/16S2202F
R2467	RS1/16S3301F	RS1/16S3301F
R2452, R2453	RS1/16S3302F	RS1/16S3302F
R2457-R2460	RS1/16S4701F	RS1/16S4701F
R2506	RS3LMF151J	RS3LMF151J
VR2401, VR2402	CCP1390	CCP1390
Other Resistors	RS1/16S###J	RS1/16S###J

OTHERS

2401 HEATSINK	ANH1614	ANH1614
2401 SCREW	BBZ30P080FTC	BBZ30P080FTC

43 SCAN A ASSY

SEMICONDUCTORS

IC3001-IC3006	SN755866PZP	SN755866PZP
---------------	-------------	-------------

CAPACITORS

C3001, C3002, C3012 (0.1/250V)	ACG1088	ACG1088
C3013, C3023, C3024 (0.1/250V)	ACG1088	ACG1088
C3034, C3035, C3045 (0.1/250V)	ACG1088	ACG1088
C3046, C3056, C3057 (0.1/250V)	ACG1088	ACG1088
C3005, C3008, C3016, C3019, C3026	CCSRCH101J50	CCSRCH101J50
C3029, C3037, C3040, C3048, C3051	CCSRCH101J50	CCSRCH101J50
C3060, C3063	CCSRCH101J50	CCSRCH101J50
C3007, C3018, C3033, C3044, C3050	CCSRCH181J50	CCSRCH181J50
C3062	CCSRCH181J50	CCSRCH181J50
C3006, C3011, C3017, C3022	CCSRCH331J50	CCSRCH331J50
C3031, C3032, C3042, C3043, C3049	CCSRCH331J50	CCSRCH331J50
C3055, C3061, C3066	CCSRCH331J50	CCSRCH331J50
C3009, C3010, C3020, C3021, C3028	CCSRCH390J50	CCSRCH390J50
C3030, C3039, C3041, C3053, C3054	CCSRCH390J50	CCSRCH390J50
C3064, C3065	CCSRCH390J50	CCSRCH390J50
C3003, C3014, C3025, C3036, C3047	CKSRYB105K6R3	CKSRYB105K6R3
C3058	CKSRYB105K6R3	CKSRYB105K6R3

RESISTORS

R3003, R3011, R3017, R3025, R3030	RAB4C221J	RAB4C221J
-----------------------------------	-----------	-----------

7	8	
Mark No.	Description	Part No.
R3036	Other Resistors	RAB4C221J
		RS1/16S###J
OTHERS		
CN3001 13P CONNECTER NONPB	AKP1261	AKP1261
K3001, K3004, K3009, K3015, K3017	AKX9002	AKX9002
K3019, K3021 TEST PIN	AKX9002	AKX9002
43 SCAN B ASSY		
SEMICONDUCTORS		
IC3201-IC3206	SN755866PZP	SN755866PZP

CAPACITORS

C3201, C3211, C3212 (0.1/250V)	ACG1088	ACG1088
C3222, C3223, C3233 (0.1/250V)	ACG1088	ACG1088
C3234, C3244, C3245 (0.1/250V)	ACG1088	ACG1088
C3255, C3256, C3266 (0.1/250V)	ACG1088	ACG1088
C3203, C3204, C3214, C3215, C3226	CCSRCH101J50	CCSRCH101J50
C3228, C3237, C3239, C3247, C3251	CCSRCH101J50	CCSRCH101J50
C3258, C3259	CCSRCH101J50	CCSRCH101J50
C3206, C3217, C3232, C3243, C3249	CCSRCH181J50	CCSRCH181J50
C3261	CCSRCH181J50	CCSRCH181J50
C3205, C3210, C3216, C3221	CCSRCH331J50	CCSRCH331J50
C3230, C3231, C3241, C3242, C3248	CCSRCH331J50	CCSRCH331J50
C3254, C3260, C3265	CCSRCH331J50	CCSRCH331J50
C3208, C3209, C3219, C3220, C3227	CCSRCH390J50	CCSRCH390J50
C3229, C3238, C3240, C3252, C3253	CCSRCH390J50	CCSRCH390J50
C3263, C3264	CCSRCH390J50	CCSRCH390J50
C3202, C3213, C3224, C3235, C3246	CKSRYB105K6R3	CKSRYB105K6R3
C3257	CKSRYB105K6R3	CKSRYB105K6R3

RESISTORS

R3202, R3210, R3216, R3224, R3229	RAB4C221J	RAB4C221J
R3235	RAB4C221J	RAB4C221J
Other Resistors	RS1/16S###J	RS1/16S###J

OTHERS

CN3201 13P CONNECTER NONPB	AKP1261	AKP1261
K3203, K3208, K3214, K3216, K3218	AKX9002	AKX9002
K3221 TEST PIN	AKX9002	AKX9002

AV I/O ASSY

[AV I/O BLOCK]

SEMICONDUCTORS

IC7609	24LCS21A	24LCS21A
IC7610, IC7613	AN5870SB	AN5870SB
IC7602, IC7605-IC7607	BA4558F-HT	BA4558F-HT
IC7603	BD3869AF	BD3869AF
△IC7604	NJM78L09UA	NJM78L09UA
IC7601, IC7608	TC4052BFT	TC4052BFT
IC7612	TC74AC04FT	TC74AC04FT
IC7611	TC74VHCT541AFT	TC74VHCT541AFT
Q7602, Q7605, Q7702	2SC4116	2SC4116
Q7603	DTA124EUA	DTA124EUA
Q7604, Q7606-Q7608	DTC124EUA	DTC124EUA
Q7701	HN1C01FU	HN1C01FU
Q7601	RN1902	RN1902
Q7609	SM6K2	SM6K2
D7601	1SS301	1SS301
D7606-D7608, D7610, D7611	1SS302	1SS302
D7613, D7614, D7616, D7617	1SS302	1SS302
D7619, D7701	1SS355	1SS355

Mark No. Description**Part No.**D7602, D7603, D7605, D7609
D7604UDZS5.6B
UDZS6.8B**Mark No. Description****Part No.****CAPACITORS**C8706, C8707
C8708, C8714
C8704, C8718
C8717, C8720
C8722-C8724CCSRCH120J50
CEHAT470M16
CEHAT471M6R3
CKSRYB103K50
CKSRYB471K50C8709
C8701-C8703, C8705, C8711-C8713
C8715, C8716, C8719, C8721, C8725CKSRYB472K50
CKSSYF104Z16
CKSSYF104Z16**RESISTORS**R8719, R8720, R8723, R8724, R8726
R8702, R8704, R8745
R8736
Other ResistorsRAB4C101J
RAB4C103J
RS1/16S1302F
RS1/16S###J**OTHERS**CN8701 PLUG 8-P
K8701-K8703 TEST PIN
X8702 CERAMIC RESONATOR
X8701 CRYSTAL OSCILLATOR
CN8704 PLUG(6P)AKM1225
AKX9002
ASS1168
ASS1172
KM200NA6**[DVI BLOCK]****SEMICONDUCTORS**IC7502
IC7511
IC7503
IC7504-IC7510
Q750324LCS21A
BD6522F
SII1161CTU-K
TC74LCX541FT
DTA124EUAQ7501, Q7502
D7501
D7503, D7504
D7502DTC124EUA
1SS301
1SS302
UDZS6.8B**COILS AND FILTERS**

F7506-F7511

ATF1211

CAPACITORSC7524, C7526, C7530, C7532
C7534, C7535, C7537, C7538
C7541, C7542, C7546, C7548-C7550
C7504, C7507
C7528, C7578, C7579CCSRCH101J50
CCSRCH101J50
CCSRCH101J50
CCSRCH221J50
CEHAT101M10C7522
C7502, C7510, C7516, C7518
C7503, C7506
C7514, C7520, C7573-C7577
C7501, C7509, C7513, C7515, C7517CEHAT221M6R3
CEHAT470M16
CKSRYB222K50
CKSRYB471K50
CKSSYF104Z16C7519, C7521, C7523, C7525, C7527
C7529, C7531, C7533, C7536
C7539, C7540, C7543-C7545, C7547
C7551-C7559CKSSYF104Z16
CKSSYF104Z16
CKSSYF104Z16
CKSSYF104Z16**RESISTORS**R7560-R7565, R7568-R7573
R7524-R7529, R7536, R7540
R7552-R7555
R7578-R7590
R7538RAB4CQ0R0J
RAB4CQ100J
RAB4CQ100J
RAB4CQ470J
RS1/16S3900FR7597, R7574-R7577
R7533
Other ResistorsRS1/16SS0R0J
RS1/16SS473J
RS1/16S###J**A CAPACITORS**C7633, C7634
C7673, C7674
C7631, C7632
C7611, C7612
C7722CCSRCH101J50
CCSRCH220J50
CCSRCH221J50
CCSRCH471J50
CEHAT100M50C7654
C7665
C7623, C7648
C7705
C7714, C7716, C7718CEHAT101M10
CEHAT101M16
CEHAT220M50
CEHAT221M6R3
CEHAT331M10**B C7619, C7635, C7637, C7695, C7697
C7721**CEHAT470M16
CEHAT470M16C7681, C7686, C7690
C7601, C7602, C7609, C7610, C7614
C7616, C7638, C7639, C7643, C7653CEHAT471M16
CKSQYB225K10
CKSQYB225K10C7627-C7630, C7640, C7650
C7642, C7652, C7660, C7661, C7666
C7676, C7680, C7685, C7689
C7698-C7703, C7707, C7712, C7713
C7715, C7717CKSRYB102K50
CKSRYB103K50
CKSRYB103K50
CKSRYB103K50
CKSRYB103K50**C C7621, C7622
C7603, C7620, C7662, C7663, C7667
C7675, C7677, C7678, C7684
C7693, C7694, C7723
C7641, C7651**CKSRYB104K16
CKSRYB105K10
CKSRYB105K10
CKSRYB105K10
CKSRYB222K50C7646, C7656
C7617, C7618, C7624-C7626, C7636
C7644, C7647, C7649, C7655, C7664
C7668, C7679, C7682, C7683, C7687
C7691, C7692, C7696, C7704, C7706CKSRYB471K50
CKSSYF104Z16
CKSSYF104Z16
CKSSYF104Z16
CKSSYF104Z16

C7708-C7711, C7720

CKSSYF104Z16

D RESISTORSR7751-R7753
R7712, R7725
R7699-R7701, R7741-R7743
R7653, R7654, R7673, R7674
R7709-R7711RS1/16S2200F
RS1/16S2201F
RS1/16S27R0F
RS1/16S3301F
RS1/16S75R0F

Other Resistors

RS1/16S###J

OTHERSCN7602, CN7603 JACK
JA7606, JA7607 15P D-SUB SOCKET
CN7601 PLUG(15P)AKN1069
AKP1241
KM200NA15**[IF UCOM BLOCK]****SEMICONDUCTORS**IC8705
IC8702
IC8703
IC8701
IC870424LC01B
HD64F3687FP
PST9230N
TC74VHC08FT
TC7W126FUQ8701
Q8708
Q87022SJ461A
DTA124EUA
DTC124EUA**COILS AND FILTERS**

L8702

LCTAWR68J2520

Mark No.	Description	Part No.
OTHERS		
CN7501	JACK	AKN1069
CN7503	DVI SOCKET (24P)	AKP1216
43 X DRIVE ASSY		
OTHERS		
1001	DRIVE SIRICON SHEET	AEH1062
1001	PLATE X	ANG2664
1001	DRIVE HEATSINK A	ANH1613
1001	SCREW	BMZ30P080FTC
1002	SCREW	PMB30P060FNI
[43 X LOGIC BLOCK]		
SEMICONDUCTORS		
IC1002		TC74ACT540FT
IC1001		TC74ACT541FT
IC1003		TC74VHC08FT
CAPACITORS		
C1001		CEHAT470M25
C1002-C1004		CKSSYB104K10
RESISTORS		
R1001, R1002, R1005		RAB4C470J
R1003, R1004, R1007		RAB4C472J
Other Resistors		RS1/16S###J
OTHERS		
CN1001	30P FFC CONNECTER	AKM1218
[43 X RESONANCE BLOCK]		
SEMICONDUCTORS		
IC1103		BA10393F
IC1101, IC1102		TND506MD
Q1113		2SC4116
Q1102, Q1103, Q1111, Q1112		2SK3555-01MR
Q1105		2SK3592-01S
Q1108, Q1109		2SK3864
Q1101, Q1104, Q1107, Q1110		QSZ2
D1109, D1122		1SS302
D1112, D1119, D1135, D1136		1SS355
D1101, D1102, D1104, D1105		D1FL40
D1107, D1108, D1111, D1114-D1117		D1FL40
D1120, D1121, D1127, D1128		D1FL40
D1103, D1113, D1118, D1125		RF2001T3D
D1129, D1130		RF2001T3D
D1110, D1123		UDZS16(B)
COILS AND FILTERS		
L1104		ATH1119
L1102		ATH1133
L1103, L1105		ATH1134
L1101		LFEA470J
CAPACITORS		
C1112, C1113, C1125-C1127		ACE1168
C1111, C1124, C1134 (100P/630V)		ACG1104
C1135 (100P/630V)		ACG1104
C1109, C1119 (0.22/250V)		ACG1112
C1101, C1105, C1116, C1117		CCSRCH331J50
C1102, C1118		CKSRYB105K6R3
C1128, C1130-C1132		CKSSYB104K10

Mark No.	Description	Part No.
C1104, C1108, C1115, C1122		CKSYB105K25
RESISTORS		
R1116, R1122		RS1/10S1003F
R1133, R1143-R1145		RS1/10S100J
R1155, R1156		RS1/10S220J
R1103, R1106, R1118, R1119, R1123		RS1/10S2R2J
R1126, R1153		RS1/10S2R2J
R1136		RS1/16S1002F
R1139		RS1/16S4701F
R1130, R1134		RS1/16S8201F
R1113, R1128		RS1MMF101J
R1147, R1148		RS2MMF5R6J
VR1101-VR1104		CCP1390
Other Resistors		RS1/16S###J
OTHERS		
1101 DRIVE HEATSINK		ANH1628
1101 SCREW		PMH30P080FTC
[43 X SUS BLOCK]		
SEMICONDUCTORS		
IC1202		HCPL-M611
IC1205		NJM2872F05
IC1203, IC1207		STK795-510
IC1206		TND301S
IC1204, IC1209		TND307TD
Q1209		2SA1727
Q1203		2SD1898
Q1205		2SK2865
Q1208		DTC124EUA
Q1201		HN1B04FU
D1212		1SS302
D1211, D1213		1SS355
D1204, D1217		D1FL40
D1201, D1207		EC10QS04
D1208		UDZS5R6(B)
COILS AND FILTERS		
L1204, L1205		ATH1112
L1202, L1207		LFEA100J
L1203, L1206		LFEA470J
CAPACITORS		
C1214-C1216, C1228-C1230		ACE1163
C1245		ACE1173
C1209 (0.1/630V)		ACG1092
C1219, C1231		ACH1414
C1246		CEHAT221M25
C1201, C1203, C1207, C1220		CEHAT470M25
C1223, C1224, C1238, C1239, C1248		CEHAT470M25
C1212, C1213, C1225, C1240, C1241		CKSRYB104K16
C1243		CKSRYB104K16
C1202, C1205, C1206, C1247		CKSRYF104Z50
RESISTORS		
R1260, R1261		ACN1162
R1230		ACN1166
R1208		ACN1174
R1255		ACN1178
R1256		ACN1198
R1226, R1251		RS1MMF361J
R1235, R1236		RS2MMF121J

<u>Mark No.</u>	<u>Description</u>	<u>Part No.</u>
	Other Resistors	RS1/16S###J

OTHERS

A	KN1201-KN1205, KN1208, KN1210 KN1211, KN1212KN1214 GROUND PLATE CN1201 CONNECTOR	ANK-142 ANK-142 B12B-EH
---	---	-------------------------------

[43 X D-D CON BLOCK]**SEMICONDUCTORS**

	IC1402	MIP2E3DMU
	IC1401, IC1403	PS2701A-1(L)
	IC1404	TA76431FR
	Q1401	2SA1576A
B	Q1402	2SC4116
	D1406, D1409, D1410 D1407, D1408 D1405 D1401, D1403	D1FK70 D1FL20U(S) U1ZB330 UDZS5R6(B)

COILS AND FILTERS

	T1401	ATK1153
	L1401	LFEA101J

CAPACITORS

	C1401, C1402	ACH1361
C	C1404	CEHAT101M16
	C1405	CEHAT101M25
	C1409	CEHAT331M16
	C1403, C1407, C1408, C1411	CKSRYB104K16
	C1406	CKSRYF104Z50

RESISTORS

	R1405, R1406, R1408-R1410, R1414	RS1/10S3602F
	R1420	RS1/16S1101F
	R1403	RS1/16S2702F
	R1401, R1404	RS1/16S4701F
	R1417	RS1/16S7500F
D	VR1401	CCP1390
	Other Resistors	RS1/16S###J

PANEL SENSOR ASSY**SEMICONDUCTORS**

	IC1072	MM1522XU
	IC1071	MM3012XN

CAPACITORS

E	C1071, C1074, C1075 C1072, C1073	CKSRYB103K50 CKSRYF105Z10
---	-------------------------------------	------------------------------

RESISTORS

	R1073, R1074	RS1/16S1001F
	R1075	RS1/16SS102J
	R1071	RS1/16SS471J
	R1072	RS1/16SS473J
	Other Resistors	RS1/16S###J

X CONNECTOR A ASSY

This assembly has no service parts.

F

X CONNECTOR B ASSY

This assembly has no service parts.

• PCB parts for PDP-504CMX and PDP-434CMX

<u>Mark No.</u>	<u>Description</u>	<u>Part No.</u>	<u>Mark No.</u>	<u>Description</u>	<u>Part No.</u>
RGB ASSY					
[RGB BLOCK]					
SEMICONDUCTORS					
	IC7411	BD6522F	R7465		RS1/16S4702F
△	IC7412	M5291FP	R7460		RS1/16S6201F
	IC7402	MM1522XU	R7447		RS1/16S7500F
	IC7401	MM3012XN	R7478		RS1/16S8201F
	IC7404	NJM12904V			
△	IC7408, IC7409	PQ05DZ11	Other Resistors		
△	IC7405, IC7410	PQ20WZ11			RS1/16S###J
△	IC7406, IC7407	PQ3DZ13	OTHERS		
	IC7403	TC74VHC08FT	CN7405	PLUG120-P	AKM1203
	Q7405	2SA1586	CN7401	PLUG 15-P	AKM1232
	Q7407, Q7408, Q7410, Q7411	HN1A01FU	CN7410	PLUG50-P	AKM1270
	Q7404	HN1C01FU	[MAIN LPF BLOCK]		
	Q7401	RN1901	SEMICONDUCTORS		
	Q7409	RN1902	IC6402		AN5870SB
	D7408	1SS301	IC6404		BA7078AF
	D7407, D7409-D7414	1SS355	IC6403		BA7657F
	D7415, D7416	EC11FS2	IC6401		SM5301BS
COILS AND FILTERS			IC6407		TC74VHC08FT
L7401		ATH1125	IC6405		TC74VHC125FT
CAPACITORS			Q6419-Q6421		2SA1586
C7408		ACH1357	Q6407, Q6417		DTC124EUA
C7414, C7419, C7434 (100/25V)		ACH1374	Q6402-Q6406, Q6408, Q6410, Q6412		HN1B04FU
C7437 (100/25V)		ACH1374	D6404		1SS302
C7447, C7450 (47/16V)		ACH1391	COILS AND FILTERS		
C7416, C7423, C7424 (100/16V)		ACH1394	L6401		LCTAW4R7J2520
C7430 (100/16V)		ACH1394	L6402		LCTAWR68J2520
C7418, C7421, C7426 (100/6.3V)		ACH1396	CAPACITORS		
C7432, C7445 (100/6.3V)		ACH1396	C6409, C6436, C6437, C6462, C6469		ACH1357
C7452		ACH1396	C6402, C6405, C6406 (47/16V)		ACH1391
C7403		ACH1400	C6427, C6428, C6431 (47/16V)		ACH1391
C7428, C7429, C7448		CCSRCH221J50	C6416, C6417, C6424 (100/16V)		ACH1394
C7440, C7459-C7466		CKSRYB102K50	C6433 (100/16V)		ACH1399
C7407, C7409, C7453-C7455		CKSRYB103K50	C6439 (22/16V)		ACH1400
C7457, C7458		CKSRYB103K50	C6445		CCSRCH151J50
C7436		CKSRYB104K16	C6435, C6467, C6468		CCSRCH470J50
C7446		CKSRYB821K50	C6401, C6403, C6404, C6414, C6415		CKSRYB103K50
C7413, C7435		CKSRYF104Z50	C6423, C6429, C6430, C6432, C6438		CKSRYB103K50
C7402, C7410		CKSRYF105Z10	C6446, C6449, C6451, C6454, C6456		CKSRYB103K50
C7404-C7406, C7411, C7412, C7415		CKSSYF104Z16	C6459, C6461, C6470-C6476		CKSRYB103K50
C7417, C7420, C7422, C7425, C7427		CKSSYF104Z16	C6463		CKSRYB104K25
C7431, C7433, C7439, C7441-C7444		CKSSYF104Z16	C6408, C6411, C6412, C6421, C6455		CKSRYB105K6R3
C7449, C7451		CKSSYF104Z16	C6457, C6460		CKSRYB105K6R3
RESISTORS			C6458		CKSRYB471K50
R7402, R7405, R7417		RAB4CQ101J	C6443		CKSRYB474K10
R7426		RAB4CQ103J	C6442		CKSRYB562K50
R7480		RS1/10S1R5J	C6407, C6410, C6413, C6418-C6420		CKSSYF104Z16
R7412, R7420, R7486		RS1/16S1001F	C6425, C6426, C6434, C6440, C6441		CKSSYF104Z16
R7437, R7439, R7467, R7469, R7476		RS1/16S1002F	C6444, C6447, C6448, C6450		CKSSYF104Z16
R7461		RS1/16S1501F	C6452, C6453		CKSSYF104Z16
R7422		RS1/16S1800F	RESISTORS		
R7440, R7445		RS1/16S2201F	R6489		RAB4CQ470J
R7477		RS1/16S2202F	R6422		RS1/16S1101F
R7484		RS1/16S3301F	R6526-R6528		RS1/16S2200F
R7438		RS1/16S4700F	R6428, R6429		RS1/16S3000F
			R6547-R6549		RS1/16S75R0F
			Other Resistors		
					RS1/16S###J

Mark No. Description**Part No.****Mark No. Description****Part No.****OTHERS**

K6401-K6406 TEST PIN
CN6402 PLUG(6P)

AKX9002
KM200NA6

C6638
C6604, C6624

CKSRYB103K50
CKSRYB104K16

[MAIN AD BLOCK]**SEMICONDUCTORS**

IC6001
IC6002-IC6008
Q6001
D6001

CXA3516AR
TC74LCX541FT
2SC4116
1SS355

C6648
C6608, C6611, C6612, C6621
C6630-C6632
C6646, C6656-C6661
C6609, C6614, C6623

CKSRYB104K25
CKSRYB105K6R3
CKSRYB105K6R3
CKSRYB471K50
CKSRYB473K16

COILS AND FILTERS

L6001

LCTAWR68J2520

C6642
C6641
C6602
C6601
C6605-C6607, C6610, C6613

CKSRYB474K10
CKSRYB562K50
CKSRYB822K50
CKSRYB823K16
CKSSYF104Z16

CAPACITORS

C6001, C6005, C6010 (100/6.3V)
C6028, C6041, C6043 (100/6.3V)
C6051, C6054 (100/6.3V)
C6020
C6011
C6017

ACH1396
ACH1396
ACH1396
CCSRCH101J50
CCSRCH220J50
CCSRCH331J50

C6003, C6018, C6024, C6025
C6033, C6034, C6037, C6038, C6045
C6062-C6068
C6002, C6004, C6006-C6009
C6012-C6016, C6021-C6023

CKSRYB105K6R3
CKSRYB105K6R3
CKSRYB471K50
CKSSYF104Z16
CKSSYF104Z16

C6026, C6027, C6029-C6032
C6035, C6036, C6039, C6040, C6042
C6044, C6046-C6050, C6052, C6053
C6055-C6061

CKSSYF104Z16
CKSSYF104Z16
CKSSYF104Z16
CKSSYF104Z16

RESISTORS

R6001, R6004, R6013, R6014
R6020, R6021, R6024, R6027, R6033
R6038, R6044, R6054
R6073-R6085
R6023

RAB4CQ100J
RAB4CQ100J
RAB4CQ100J
RAB4CQ330J
RN1/16SE3001D

R6018
R6016
R6019
Other Resistors

RS1/16S2201F
RS1/16S2701F
RS1/16S3301F
RS1/16S###J

OTHERS

K6001-K6007, K6010-K6013 TEST PIN AKX9002

[SUB LPF & AD BLOCK]**SEMICONDUCTORS**

IC6602
IC6604
IC6601
IC6608-IC6614
IC6605

AD9883AKST-110
BA7078AF
SM5301BS
TC74LCX541FT
TC74VHC08FT

IC6603, IC6607
Q6603, Q6604
Q6605

TC74VHC125FT
DTC124EUA
HN1B04FU

COILS AND FILTERS

F6601
L6701

ATF1194
LCTAWR68J2520

CAPACITORS

C6635-C6637, C6640
C6633 (100/16V)
C6644

ACH1357
ACH1399
CCSRCH151J50

RESISTORS

R6699-R6710, R6723-R6728
R6729-R6734
R6608, R6613, R6621, R6627
R6643, R6644, R6667-R6672
R6676-R6678, R6681-R6685

RAB4CQ0R0J
RAB4CQ101J
RAB4CQ470J
RAB4CQ470J
RAB4CQ470J

R6612, R6619, R6620
R6625
R6607, R6611, R6626
R6601
Other Resistors

RS1/16S1000F
RS1/16S1101F
RS1/16S1300F
RS1/16S2701F
RS1/16S###J

OTHERS

K6601-K6607 TEST PIN

AKX9002

**[BUS SW1 BLOCK]
SEMICONDUCTORS**

IC5701

PD6435A

CAPACITORS

C5701 (47/16V)
C5709, C5710
C5721-C5737
C5702-C5708, C5711, C5712
C5714-C5718

ACH1391
CCSRCH150J50
CKSRYB103K50
CKSSYF104Z16
CKSSYF104Z16

RESISTORS

R5703-R5706, R5708-R5712, R5714
R5717, R5721, R5735, R5739-R5750
R5755, R5756, R5762, R5763
R5768-R5771
R5728-R5734, R5782-R5787

RAB4CQ100J
RAB4CQ100J
RAB4CQ100J
RAB4CQ100J
RAB4CQ103J

Other Resistors

RS1/16S###J

OTHERS

CN5701 PCISOKET120-P
X5701 CERAMIC RESONATOR

AKP1220
ASS1169

**[BUS SW2 BLOCK]
SEMICONDUCTORS**

IC5801

PD6435A

CAPACITORS

C5801 (47/16V)
C5809, C5810
C5802-C5808, C5811, C5812
C5814-C5818

ACH1391
CCSRCH150J50
CKSSYF104Z16
CKSSYF104Z16

5	6	
Mark No.	Description	Part No.
RESISTORS		
R5816-R5825, R5827, R5835, R5849	RAB4CQ100J	
R5852, R5854, R5856, R5858, R5860	RAB4CQ100J	
R5868-R5871, R5877	RAB4CQ100J	
R5802-R5808, R5812-R5814, R5831	RAB4CQ103J	
R5837, R5844, R5883	RAB4CQ103J	
R5845, R5850, R5851, R5853, R5855	RAB4CQ470J	
R5857, R5859, R5861-R5863, R5876	RAB4CQ470J	
Other Resistors	RS1/16S###J	

OTHERS

X5801 CERAMIC RESONATOR ASS1169

**[IC2 BLOCK]
SEMICONDUCTORS**

IC7001, IC7002 IC42S32200-7TG-K
IC7004 PE5362A
IC7003 TC74LCX125FT

COILS AND FILTERS

F7001, F7002 ATF1194

CAPACITORS

C7029, C7041 (100/6.3V) ACH1396
C7065 CCSRCH100D50
C7066-C7068 CCSRCH221J50
C7001-C7024, C7026-C7028 CKSSYF104Z16
C7032-C7040, C7042-C7063 CKSSYF104Z16

C7031 DCH1165

RESISTORS

R7034 RAB4CQ470J
R7027, R7037 RS1/16SS0R0J
R7023, R7035-R7036 RS1/16SS101J
R7001, R7008 RS1/16SS102J
R7002-R7004, R7024 RS1/16SS103J

R7006, R7009, R7012 RS1/16SS220J
R7011 RS1/16SS820J
Other Resistors RS1/16S###J

OTHERS

K7001-K7003 TEST PIN AKX9002
X7001 CRYSTAL OSCILLATOR ASS1174

**[IC3 BLOCK]
SEMICONDUCTORS**

IC7102 24LC02B(I)SN
IC7101 PD5855A

COILS AND FILTERS

F7101, F7102 ATF1194

CAPACITORS

C7103, C7120, C7138 (100/6.3V) ACH1396
C7141 CCSRCH100D50
C7101, C7102, C7104-C7119 CKSSYF104Z16
C7121-C7137, C7139, C7140, C7142 CKSSYF104Z16

RESISTORS

R7102, R7105-R7108, R7110, R7111 RAB4CQ330J
R7128, R7129, R7132, R7133 RAB4CQ330J
R7136, R7137 RAB4CQ330J
R7154 RAB4CQ470J
R7125, R7142 RS1/16SS0R0J

7	8	
Mark No.	Description	Part No.
R7120, R7150, R7151	RS1/16SS101J	
R7101	RS1/16SS103J	
R7103, R7104, R7112, R7114	RS1/16SS330J	
R7122, R7126, R7127, R7130, R7131	RS1/16SS330J	
R7134-R7135	RS1/16SS330J	
R7138, R7139, R7152	RS1/16SS330J	
R7149	RS1/16SS472J	
Other Resistors	RS1/16S###J	

OTHERS

CN7101 114PFFC CONNECTER AKM1216
K7101, K7102 TEST PIN AKX9002

**[IC3 FLASH BLOCK]
SEMICONDUCTORS**

IC7152 MBM29PL3200BE70PFV

CAPACITORS

C7152, C7153, C7155-C7158, C7160 CKSSYF104Z16
C7162 CKSSYF104Z16

RESISTORS

R7155-R7160 RS1/16SS472J
Other Resistors RS1/16S###J

**[MAIN UCOM BLOCK]
SEMICONDUCTORS**

IC7205 24LC128(I)SN
IC7201, IC7204 74VHCT00AMTC
IC7207 MB91F355APMTGE1
IC7210 PST3612UR
IC7203, IC7206 PST3628UR

IC7209 TC74VHC08FT
IC7202 TC74VHC125FT
IC7208 TC74VHCT541AFT
Q7201 2SJ461A
Q7202 DTC124EUA

D7202 1SS355
D7203 SML-310MT

CAPACITORS

C7205, C7236 ACH1391
C7143, C7203 CCSRCH220J50
C7213, C7218 CCSRCH7R0D50
C7248-C7251 CKSRYB102K50
C7235, C7245 CKSRYB103K50

C7226, C7237 CKSRYB104K16
C7230, C7242 CKSRYB104K25
C7216 CKSRYB472K50
C7201, C7202, C7209-C7212 CKSSYF104Z16
C7214, C7215, C7219-C7225 CKSSYF104Z16

C7227-C7229, C7232-C7234, C7238 CKSSYF104Z16
C7240, C7241, C7243, C7244 CKSSYF104Z16
C7246, C7247 CKSSYF104Z16

RESISTORS

R7231 RAB4CQ0R0J
R7229 RAB4CQ101J
R7256 RAB4CQ103J
R7218, R7219, R7284-R7286, R7301 RAB4CQ470J
R7309, R7311-R7314, R7317 RAB4CQ470J

Mark No. Description**Part No.**

R7201
R7212, R7232
R7208-R7209, R7216-R7217
R7207, R7221-R7223, R7225-R7226
R7228, R7230, R7249, R7251, R7262

R7263, R7278-R7279, R7310
R7315-R7316, R7318, R7339
Other Resistors

RAB4CQ472J
RS1/16S1202F
RS1/16SS0R0J
RS1/16SS470J
RS1/16SS470J
RS1/16SS470J
RS1/16S###J

OTHERS

CN7201 PLUG 8-P
X7201 CERAMIC RESONATOR

AKM1225
ASS1170

SIDE KEY ASSY**SWITCHES AND RELAYS**

S4801-S4811

ASG1088

OTHERS

CN4801 8P CONNECTER

AKM1207

DIGITAL VIDEO ASSY**[DIGITAL IF BLOCK]****COILS AND FILTERS**

F5001, F5002, F5004

ATF1213

RESISTORS

R5101-R5115, R5131
Other Resistors

RAB4C470J
RS1/16SS###J

OTHERS

CN5001 114PFFC CONNECTER
CN5002 CONNECTOR

AKM1216
AKM1281

**[MODULE UCOM BLOCK]
SEMICONDUCTORS**

IC5206
IC5201
IC5205
IC5208
IC5214, IC5215

BR24L04FJ-W
M30622F8PGP-K
PST3628UR
SN74AHC08PW
SN74AHC32PW

IC5211, IC5212
IC5209
Q5201
Q5202
D5217

SN74AHC541PW
TC7W126FU
2SJ461A
DTC143EUA
1SS355

D5207-D5212
D5201

DAN202U
SML-310LT

SWITCHES

S5201

ASH1047

CAPACITORS

C5213, C5225
C5205
C5206, C5223, C5231, C5245-C5262
C5264
C5263

ACH1357
CKSRYB472K50
CKSSYB102K50
CKSSYB102K50
CKSSYB104K10

C5202-C5204, C5207, C5208
C5210-C5212, C5218, C5224
C5226, C5227, C5243, C5244

CKSSYF104Z16
CKSSYF104Z16
CKSSYF104Z16

Mark No. Description**Part No.****RESISTORS**

R5209, R5211, R5212, R5235
R5254, R5255, R5265, R5266
R5205
R5270, R5271
R5256, R5257

R5294
Other Resistors

RAB4C101J
RAB4C101J
RAB4C103J
RAB4C472J
RAB4C474J

RS1/16S0R0J
RS1/16S###J

OTHERS

CN5201 PLUG 8-P
CN5202 CONNECTOR
⚠ X5201 CERAMIC RESONATOR

AKM1225
AKM1274
ASS1178

**[PANEL FLASH BLOCK]
SEMICONDUCTORS**

IC5305
IC5303
IC5301
IC5302
Q5301

MBM29PL160BD-75PFTN
PST3612UR
PST3628UR
SN74AHC08PW
RN1901

D5301-D5310

DA204U

CAPACITORS

C5320
C5321, C5322
C5311, C5314
C5303, C5306
C5304, C5307

CCSRCH470J50
CCSRCH471J50
CKSRYB104K16
CKSRYB472K50
CKSSYB102K50

C5301, C5302, C5305, C5309, C5313
C5316

CKSSYF104Z16
CKSSYF104Z16

RESISTORS

R5317, R5318
Other Resistors

RAB4C101J
RS1/16SS###J

OTHERS

CN5301 PLUG 15-P
⚠ X5302 CRYSTAL OSCILLATOR
⚠ X5301 CRYSTAL OSCILLATOR

AKM1232
ASS1174
ASS1182

**[IC4 BLOCK]
SEMICONDUCTORS**

IC5401
D5401
D5402

PEG054A-K
SML-310LT
SML-310MT

COILS AND FILTERS

F5401, F5403, F5409, F5410

ATF1213

CAPACITORS

C5401, C5413, C5417 (100/6.3V)
C5424 (100/6.3V)
C5434, C5435
C5402-C5412, C5414-C5416
C5418-C5423, C5425-C5431

ACH1396
ACH1396
CKSSYB102K50
CKSSYF104Z16
CKSSYF104Z16

RESISTORS

R5406, R5421
R5408-R5413, R5415, R5416, R5419
R5422
R5405

RAB4C101J
RAB4C220J
RAB4C220J
RS1/16S5601F

5	6	
Mark No.	Description	Part No.
R5420	RS1/16SS0R0J	
R5426-R5428	RS1/16SS101J	
R5423, R5425	RS1/16SS103J	
R5429-R5430	RS1/16SS122J	
R5417-R5418	RS1/16SS220J	
Other Resistors	RS1/16S###J	

**[ADDRESS CN BLOCK]
RESISTORS**

All Resistors	RS1/16SS###J
---------------	--------------

OTHERS

CN5521	AKM1201
△ CN5501-CN5508	AKM1217
CN5511	AKM1218

**[DIGITAL DD CON BLOCK]
SEMICONDUCTORS**

△ IC5605	BA90BC0FP
△ IC5604	MM1665AT
Q5601	HN1C01FU
D5602, D5609	DAN202U
D5601	HZU2R2(B)

D5604	UDZS5R1(B)
-------	------------

CAPACITORS

C5601, C5603, C5614 (100/16V)	ACH1394
C5616 (100/16V)	ACH1394
C5602, C5604, C5615, C5617	CKSRYB103K50
C5605, C5606	CKSSYF104Z16

RESISTORS

R5610	RS1/16SS101J
R5606-R5607	RS1/16SS102J
R5608-R5609, R5611, R5628	RS1/16SS223J
Other Resistors	RS1/16S###J

OTHERS

△ CN5602 CONNECTOR	AKM1278
△ CN5601 CONNECTOR	AKM1282

**AUDIO AMP ASSY
SEMICONDUCTORS**

IC5002	BA4558F-HT
△ IC5003	LA4625
△ IC5004	PQ12DZ11
△ IC5001	SI-8120S
Q5005, Q5007, Q5008	2SA1586

Q5001, Q5009	2SC4116
Q5011, Q5012	2SD2114K
Q5013	DTA124EUA
D5003	1SS301
D5001	1SS302

D5002	1SS355
D5005	RK46

COILS AND FILTERS

L5002	ATH1159
-------	---------

7	8	
Mark No.	Description	Part No.
CAPACITORS		
C5049, C5080		CEHAT101M16
C5045		CEHAT220M50
C5010		CEHAT221M10
C5022		CEHAT222M16
C5047, C5048, C5081		CEHAT2R2M50

C5050		CEHAT330M25
C5005-C5008, C5016		CEHAT470M16
C5051		CEHATR47M50
C5019, C5020		CEHAZL471M25
C5002, C5004, C5017, C5027		CKSRYB103K50

C5055-C5058		CKSRYB104K25
C5043, C5044		CKSRYB222K50

RESISTORS

R5049-R5052		RD1/4MUF2R2J
R5053-R5056		RS1/10S5R6J
R5001		RS1/16S1502F
R5005, R5006, R5009, R5010		RS1/16S3301F
R5003, R5004, R5007, R5008		RS1/16S6801F

Other Resistors	RS1/16S###J
-----------------	-------------

OTHERS

CN5002 PLUG(6P)		KM200NA6
5001 SCREW		VBB30P100FNI
KN5001, KN5002		VNF1084
WRAPPING TERMINAL		

**COMM SLOT ASSY
SEMICONDUCTORS**

IC9451		SP3232ECY
IC9452, IC9454		TC74VHC00FT
IC9453, IC9455		TC74VHC125FT

CAPACITORS

C9455		CEJQ470M6R3
C9452, C9469-C9472		CKSRYB471K50
C9451, C9453, C9454, C9456-C9458		CKSSYF104Z16
C9462, C9467, C9468		CKSSYF104Z16

RESISTORS

Other Resistors	RS1/16S###J
-----------------	-------------

OTHERS

3500 SCREW		ABA1318
3330 RIVET (PLASTIC)		AEP-211
JA9453 9P D-SUB SOCKET		AKP1240
JA9451, JA9452 6PIN MINI-DIN JACK		AKP1254
3334 PROTECT SHEET 92		AMR3396

3214 SLOT PANEL 92		ANG2611
3526 HEXAGON HEADED SCREW		BBA1051
9451 SCREW TERMINAL		VNE1949

**VIDEO SLOT I/F ASSY
SEMICONDUCTORS**

IC8952		24LC01B
Q8953		DTC124EUA
D8951, D8952		UDZS5.6B

COILS AND FILTERS

L8951		ATX1008
-------	--	---------

Mark No.	Description	Part No.
CAPACITORS		
C8952		CEHAT470M16
C8953		CKSSYF104Z16
RESISTORS		
Other Resistors		RS1/16S###J
OTHERS		
CN8953 SOKET120-P		AKP1219
CN8954 PCISOKET184		AKP1251
CN8955 SOKET50-P		AKP1253
KN8951, KN8952 GROUND PLATE		ANK1664
CN8952 L-PLUG(11P)		KM200NA11L

Mark No.	Description	Part No.
LED OPT ASSY		
SEMICONDUCTORS		
Q9652		DTC143EUA
Q9051		HN1B04FU
Q9651		RN2901
D9051		S9561
D9652		SML-310MT
D9651		SML-311UT
CAPACITORS		
C9652-C9655		CCSRCH101J50
C9054		CKSRYB103K50
C9052, C9055, C9056		CKSRYB105K10
C9051, C9053, C9651		CKSSYF104Z16

SP TERMINAL L ASSY

Mark No.	Description	Part No.
SEMICONDUCTORS		
IC9752		MM1522XU
IC9751		MM3012XN

COILS AND FILTERS

L9701, L9702		ATF1206
--------------	--	---------

CAPACITORS

C9703, C9704		CCSRCH101J50
C9706, C9708-C9711		CCSRCH221J50
C9753, C9756		CEAT470M16
C9754		CKSRYB103K50
C9752, C9755		CKSRYB105K10

C9705		CKSRYB332K50
C9707		CKSRYF473Z50
C9751, C9757		CKSSYF104Z16

RESISTORS

R9703, R9704		RD1/2MMF100J
R9757, R9760		RS1/16S1001F
Other Resistors		RS1/16S###J

OTHERS

CN9701 SPEAKER TERMINAL 2-P		AKE1041
CN9702 PLUG(6P)		KM200NA6

SP TERMINAL R ASSY**COILS AND FILTERS**

L9801, L9802		ATF1206
--------------	--	---------

CAPACITORS

C9804, C9805		CCSRCH101J50
C9801, C9808-C9811		CCSRCH221J50
C9806		CKSRYB332K50
C9807		CKSRYF473Z50

RESISTORS

R9803, R9804		RD1/2MMF100J
Other Resistors		RS1/16S###J

OTHERS

CN9802 SPEAKER TERMINAL 2-P		AKE1041
-----------------------------	--	---------

AV I/O IF ASSY**OTHERS**

CN2101 PCISOKET120-P		AKP1220
----------------------	--	---------

RESISTORS

Other Resistors		RS1/16S###J
-----------------	--	-------------

COMM SLOT IF ASSY**SEMICONDUCTORS**

IC8901		TC74VHC00FT
Q8902		2SC4116

COILS AND FILTERS

L8901		LCTAW221J3225
-------	--	---------------

CAPACITORS

C8902		CKSRYB104K25
C8901		CKSSYF104Z16

RESISTORS

Other Resistors		RS1/16S###J
-----------------	--	-------------

OTHERS

CN8904 EDGE CARD CONN		AKP1252
CN8902 L-PLUG(10P)		KM200NA10L
CN8903 L-PLUG(11P)		KM200NA11L
CN8905 L-PLUG(6P)		KM200NA6L

KEY CONTROL ASSY**SEMICONDUCTORS**

IC9001		PD5719A
Q9001		2SC4116
D9001-D9003, D9005-D9008		1SS302
D9004		1SS355

COILS AND FILTERS

F9001-F9008		DTL1069
-------------	--	---------

CAPACITORS

C9006-C9008		CCSRCH101J50
C9005		CEAT470M16
C9001-C9003		CKSRYB472K50
C9004		CKSSYF104Z16

RESISTORS

R9008		RAB4C182J
Other Resistors		RS1/16S###J

OTHERS

CN9002 8P CONNECTER		AKM1207
X9001 CERALOCK		ASS1162
CN9001 L-PLUG(3P)		KM200NA3L

Mark No. **Description** **Part No.**

IR RECEIVE ASSY

SEMICONDUCTORS

Q4901	2SC4116
D4902	1SS302
D4901	1SS355

A

CAPACITORS

C4905	CCSRCH101J50
C4901	CEAT470M16
C4903	CKSRYB102K50
C4907	CKSRYB103K50
C4902, C4904	CKSSYF104Z16

RESISTORS

Other Resistors	RS1/16S###J
-----------------	-------------

B

COVER ASSY

This assembly has no service parts.

POWER SUPPLY UNIT

This assembly has no service parts.

C

D

E

F

6. ADJUSTMENT



- A
1. At shipment, the unit is adjusted to its best conditions. Normally, it is not necessary to readjust even if an assembly is replaced. If the adjustment is shifted or if it becomes necessary to readjust because of part replacement, etc., perform the adjustment as described below.
 2. Any value changed in Service/Factory mode will be stored in memory as soon as it is changed. Before readjustment, take note of the original values for reference in case you need to restore the original settings.
 3. Use a stable AC power supply.

6.1 ADJUSTMENT REQUIRED WHEN THE SET IS REPAIRED OR REPLACED

■ When any of the following assemblies is replaced

B	POWER SUPPLY Unit	➔	No adjustment required
	DIGITAL VIDEO Assy	➔	Refer to the "7.1.6 BACKUP THE ADJUSTMENT VALUES FOR THE MAIN UNIT."
	50 (43) X DRIVE Assy	➔	No adjustment required
	50 (43) Y DRIVE Assy	➔	No adjustment required
	AV I/O Assy	➔	No adjustment required
C	RGB Assy	➔	No adjustment required
	VIDEO SLOT Assy	➔	No adjustment required
	Other assemblies	➔	No adjustment required
	Service Panel	➔	Refer to the "6.6 METHOD FOR REPLACING THE SERVICE PANEL ASSY."

■ When any part in the following assemblies is replaced

D	POWER SUPPLY Unit	➔	The assembly must be replaced as a unit, and no part replacement is allowed.
	DIGITAL VIDEO Assy	➔	No adjustment required
	50 (43) X DRIVE Assy (IC1101, IC1202)	➔	Refer to the "6.2 DRIVE ASSY ADJUSTMENT."
	50 (43) Y DRIVE Assy (IC2201, IC2202)	➔	Refer to the "6.2 DRIVE ASSY ADJUSTMENT."
E	AV I/O Assy	➔	Replacement and repair of IC7610 and IC8705 are impossible.
	RGB Assy	➔	Replacement and repair of IC6001, IC6401, IC6403, IC6601, IC6602 and IC7205 are impossible.
	VIDEO SLOT Assy	➔	Replacement and repair of IC6107, IC6255, IC6257 and IC7902 are impossible.
	Other assemblies	➔	No adjustment required

6.2 DRIVE ASSY ADJUSTMENT

How to readjust the timing of the control signals when the DRIVE Assy TND506MD is to be replaced

As there is a large difference in delay time among the individual TND506MDs, timing adjustment has been made on each TND506MD in the unit process. If the TND506MD is replaced on the X or Y Drive Assy, readjustment of the timing of the control signals is required.

Assy	Replaced IC	Signal for which Readjustment is Required
X DRIVE	IC1101	XSUS-U2 & XSUS-D2
	IC1102	XSUS-U1 & XSUS-D1
Y DRIVE	IC2201	YSUS-U1 & YSUS-D1
	IC2202	YSUS-U2 & YSUS-D2

How to adjust

Adjust the timing between the startup of the control signals of SUS-U1, SUS-D1, SUS-U2, and SUS-D2 and the startup of the voltage between the gate and the source of the output FET, with the VR resistors that are inserted in the signal line in series. When adjusting, set the unit to Drive OFF mode, and V_{sus} to 0 V. (For details on how to set to Drive OFF mode, see "7.1.5 Power on/off function for the large-signal system".)

Specified values for adjustment and adjustment points

Signal Name	Set Value for Delay Time	X DRIVE			Y DRIVE		
		Input Signal	Output Signal	Adjustment VR	Input Signal	Output Signal	Adjustment VR
SUS-U1	$375\text{ns} \pm 10\text{ns}$	K1005	Q1108	VR1103	K2025	Q2202	VR2201
SUS-D1	$375\text{ns} \pm 10\text{ns}$	K1009	Q1112	VR1104	K2027	Q2205	VR2202
SUS-U2	$375\text{ns} \pm 10\text{ns}$	K1008	Q1103	VR1101	K2022	Q2208	VR2203
SUS-D2	$375\text{ns} \pm 10\text{ns}$	K1006	Q1105	VR1102	K2024	Q2212	VR2204

Note: Connect GND of the probe with DGND (DGND: X Drive Assy: K1020, Y Drive Assy: K2010) for input signal. For outputting a signal, obtain a signal from the FET gate terminal. For adjustment, magnify any pulse in the waveform.

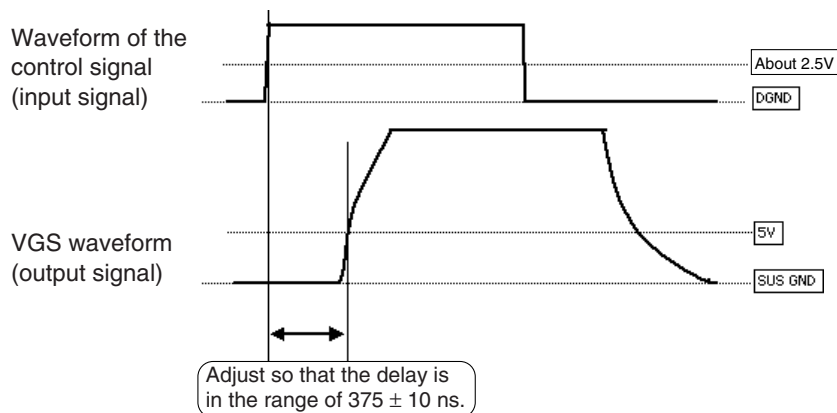

Actually measured waveforms

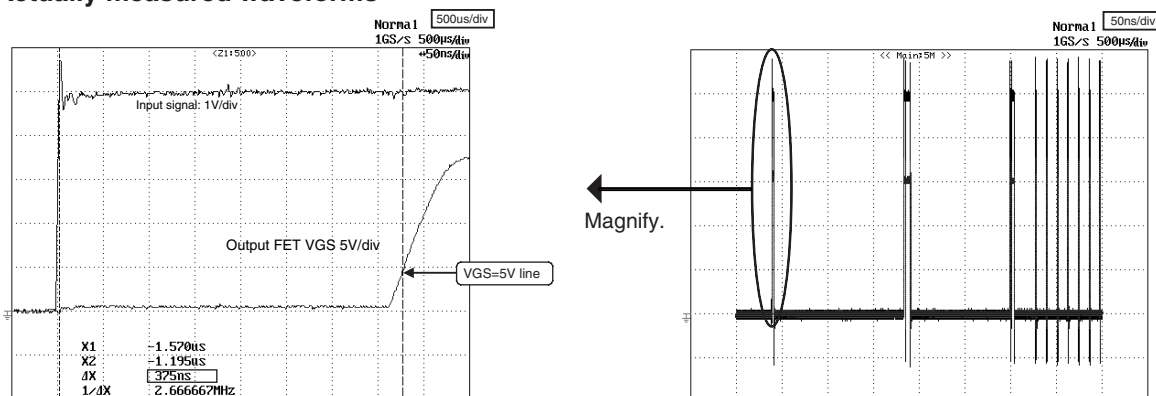

6.3 SERVICE FACTORY MODE

Commands in Service/Factory mode must be issued using the remote control unit supplied with the Plasma Display.

State Transition Diagram

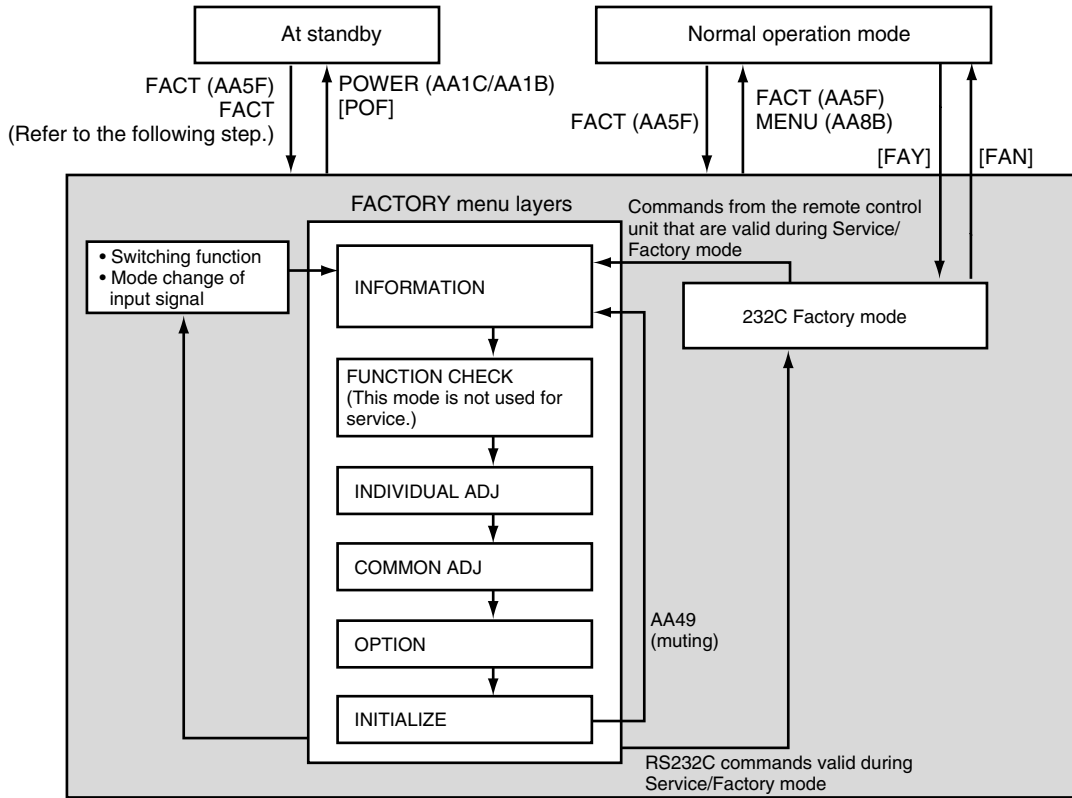

6.4 HOW TO ENTER FACTORY MODE

For adjustments, it is necessary to enter Service/Factory mode. There are two ways to enter Service/Factory mode: by using the remote control unit, or by using RS232C commands from your PC.

When the unit is in Standby (STB) Mode

- Please refer to the technical document (Service Knowhow) same as previous model (G4 model)

When the power is on

No.	Method	Procedures
1	Remote control unit	When the conventional Service/Factory code (AA5F) is sent, the unit will enter Service/Factory mode.
2	PC	Connect your PC via its RS232C port, and send the FAY command.

■ Operation when Service/Factory mode is entered

● Functions whose settings are set to OFF

The settings of the following functions are set to OFF when Service/Factory mode is entered (including when this mode is entered by receiving the FAY command):

- SPLIT (The display will become that of the main input.)
- STILL
- MASK CONTROL
- ORBITER
- POINT ZOOM

● User's setting data

User setting data are set as follows:

- Although user's adjustment data for video/audio adjustment and various adjustment are stored in memory, they are not reflected on the display.
- Although user's adjustment data for display are stored in memory, display adjustment data are reset to the default settings.
- Screen size and sound volume reflect user settings.
- The COLOR DECODING and SIGNAL FORMAT settings are reset to the default values.

● Setting data for Integrator mode

Setting data for Integrator mode will change as follows:

- Although video/audio adjustment data and various data for Integrator mode are stored in memory, they are not reflected on the display.
- Although adjustment data for display in Integrator mode are stored in memory, display adjustment data are reset to the default settings.

■ Functions of the keys on the remote control unit in Service/Factory mode

SR Function	Main Function	Description
MUTING	Switching main items	For shifting to the next (top) main item
▼ (DOWN)	Switching subitems	For shifting to the next (downward) subitem
▲ (UP)	Switching subitems	For shifting to the previous (upward) subitem
◀ (LEFT)	Increasing adjustment value	For increasing adjustment value
▶ (RIGHT)	Decreasing adjustment value	For decreasing adjustment value
SET	Shifting layers	For shifting to lower or upper layer
INPUT *	Switching inputs	For switching the input to *
STANDBY/ON	POWER OFF	For turning off the power
FACTORY	Service/Factory OFF	For setting Service/Factory mode to OFF
MENU	Service/Factory OFF	For setting Service/Factory mode to OFF
POINT ZOOM	Matrix change	RGB → YCBR (Component1) → YPBR (Component2)
SPLIT	Main screen/Sub screen change	MAIN → SUB

Main-item indications

Four parameters are displayed:

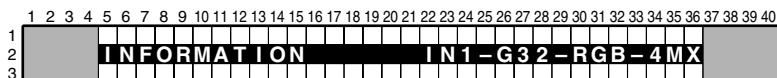

1 2 3 4

1 Input function

When there is not a video card

Input Functions	On-Screen Display
IN1, IN2	IN1, IN2

When there is a video card

Input Functions	On-Screen Display
IN1 to IN5	IN1 to IN5

2 SIG mode and screen size

Note: See SIG-Mode Tables. (See next page.)

3 Color system and signal type

When there is not a video card

Color System and Signal Type	On-Screen Display
RGB	RGB
Digital video signal	DIG

When there is a video card

Color System and Signal Type	On-Screen Display
NTSC	NTV/NTS
PAL	PLV/PLS
SECAM	SCV/SCS
4.43NTSC	4NV/4NS
PAL M	PMV/PMS
PAL N	PNV/PNS
BLACK/WHITE	BWV/BWS
Y / Cb / Cr	CBR
Y / Pb / Pr	PBR
RGB	RGB
Digital video signal	DIG

4 Option (Destination, etc.)

Options	On-Screen Display
CMX/MXE	4MX

● SIG-Mode Table

The signal mode is displayed in three characters:

First character: Resolution of the input signal (numerics for the video signals, and alphabets for the PC signals)

Second character: Grouping of the vertical frequencies

2nd Character	Reference Vertical Frequency	Area	Remarks
–	–	– 20.0	No signal
B		20.0 to 28.0	
C		28.0 to 45.0	
1	50	45.0 to 54.5	
2	56	54.5 to 58.2	
3	60	58.2 to 63.0	
4	66	63.0 to 68.0	
5	70	68.0 to 73.4	
6	For interpolation of 72-Hz	73.4 to 73.9	For distinguishing between 70-Hz or 75-Hz area
7	75	73.9 to 80.0	
8	85	80.0 to 88.5	
?	–	91.5 –	Out of range

Third character: Selection of the screen size by the user is displayed.

(○: available, ×: not available)

3rd Character	Description on GUI	VIDEO	PC
0	DOT BY DOT	×	○
1	4 : 3	○	○
2	FULL (FULL1080i)	○	○
3	ZOOM	○	×
4	WIDE	○	×
6	CINEMA	○	×
8	FULL (FULL1035i)	○	×
9 *	UNDERSCAN	○	×
:	PARTIAL	×	○

* This is displayed only when UNDERSCAN has been set before Service/Factory mode is entered.

In Service/Factory mode, changing from other screen sizes to UNDERSCAN cannot be performed.

● SIG-Mode Table

SIG-Mode table for video signals

SIG-Mode	Signal Type	Vertical Freq. fv (Hz)	Horizontal Freq. fh (kHz)	Dot Clock (MHz)	Remarks
13*	SDTV • 525i	60.000	15.734	13.5	
21*	SDTV • 625i	50.000	15.625	13.5	
33*	SDTV • 525p	60.000	31.469	27.000	
41*	HDTV • 1125i	50.000	28.125	74.250	
43*		60.000	33.750	74.250	
51*	SDTV • 625p	50.000	31.250	27.000	
61*	HDTV • 750p	50.000	37.500	74.250	
63*		60.000	45.000	74.250	
7B*	HDTV • 1125p	25.000	28.125	74.250	Use as OUT OF RANGE
7C*		30.000	33.750	74.250	Use as OUT OF RANGE
71*		50.000	56.250	148.500	
73*		60.000	67.500	148.500	
81*	HDTV • 1250p	50.000	62.500	148.500	
91*	288p	50.000	15.625	27.0/54.0	Use as OUT OF RANGE
93*	288p	60.000	15.750	27.0/54.0	Use as OUT OF RANGE

*: Represents the current screen-size selected.

SIG-Mode table for PC signals

SIG-Mode	Signal Type	Vertical Freq. fv (Hz)	Horizontal Freq. fh (kHz)	Dot Clock (MHz)	Remarks
A2*	640 × 400	56.422	24.825	21.052	Former 720 × 400
A5*	720 × 400	70.087	31.469	28.322	Former 640 × 400
A8*	720 × 400	85.050	37.861	35.438	New
B1*	640 × 480	49.673	24.688	19.750	640 × 480 For rescan (48/50Hz)
B3*		59.940	31.469	25.175	
B4*		66.666	35.000	30.240	
B6*		72.809	37.861	31.500	
B7*		75.000	37.500	31.500	
B8*		85.000	43.300	36.000	
C1*	848 × 480	49.540	24.621	26.000	848 × 480 For rescan (48/50Hz)
C3*		60.000	31.020	33.750	
D2*	800 × 600	56.250	35.158	36.000	
D3*		60.317	37.879	40.000	
D6*		72.188	48.077	50.000	
D7*		75.000	46.875	49.500	
D8*		85.061	53.674	56.250	
E7*	832 × 624	74.550	49.725	57.283	
F1*	1024 × 768	48.003	38.690	52.000	1024 × 768 For rescan (48/50Hz)
F3*		60.004	48.363	65.000	
F5*		70.069	56.476	75.000	
F7*		75.029	60.023	78.750	
F8*		84.997	68.677	94.500	
G1*	1280 × 768	48.014	38.507	65.000	1280 × 768 For rescan (48/50Hz)
G2*		56.250	45.113	76.150	
G3*		59.870	47.776	79.500	
G5*		69.843	56.014	95.000	
H3*	1152 × 864	60.000	53.700	79.369	
H6*		72.000	64.900	99.686	
H7*		75.000	67.500	108.000	
I7*	1152 × 870	75.061	68.681	100.300	
J4*	1152 × 900	65.950	61.800	92.940	
J7*		76.050	71.710	105.561	
K3*	1280 × 960	60.000	60.000	108.000	
L3*	1280 × 1024	60.020	63.981	108.000	
L7*		75.025	79.976	135.000	
L8*		85.024	91.146	157.500	
M3*	1400 × 1050	59.978	65.317	121.750	
M7*	1400 × 1050	74.867	82.278	156.000	
M8*	1400 × 1050	84.960	93.881	(179.500)	
N3*	1600 × 1200	60.000	75.000	162.000	
N4*		65.000	81.250	153.563	
N5*		70.000	87.500	153.563	
N7*		75.000	93.750	151.875	
N8*		85.000	106.250	157.781	
O3*	1280 × 720	59.943	44.718	74.410	

* : Represents the current screen-size selected.

INFORMATION mode

Select the main item "INFORMATION" using the MUTE key then select the subitems shown in the table below using the ▲ or ▼ key.

● Operation items

No.	Function / Display	Content	232C Command
1	VERSION (1)	The flash memory versions for each device are displayed (1)	GS1
2	VERSION (2)	The type of video card inserted in the slot is displayed:	
3	SERIAL	For displaying the serial number of the product	GNP/ GST
4	PANEL PD	Power-down and its time of occurrence are displayed. The values can be cleared.	GPD
5	PANEL SD	Shutdown and its time of occurrence are displayed. The values can be cleared.	GNG
6	TEMPERATURE	Information on temperature is displayed.	GS2/GST
7	HOURLY METER	Cumulative power-on time is displayed. The value can be cleared.	GS2
8	PULSE METER	The pulse meter values at each block are displayed. The values can be cleared.	GPM
9	P ON COUNTER	The number of times the power was turned on is displayed. The value can be cleared.	GPC
10	BACKUP EEPROM	The status of the backup data for the module microcomputer is displayed and updated.	GS2

1. VERSION (1)

● PDP-504CMX

No.	Function / Display	Content	232C Command
1	INFORMATION	IN1-G32-RGB-4MX	
2	VERSION (1)		
3	I / F	-09A	
4	MAIN	-17M	
5	WID-PRG	-14M -01A	
6	WID-DAT	-09M	
7	GUI-DAT	-08M	
8	MODULE	-51M	
9	SEQ-PRG	-51M	
10	SQ-DT-V	131W	
11	SQ-DT-P	131W	

● PDP-434CMX

No.	Function / Display	Content	232C Command
1	INFORMATION	IN1-G32-RGB-4MX	
2	VERSION (1)		
3	I / F	-09A	
4	MAIN	-17M	
5	WID-PRG	-14M -01A	
6	WID-DAT	-09M	
7	GUI-DAT	-08M	
8	MODULE	-51M	
9	SEQ-PRG	-51M	
10	SQ-DT-V	172X	
11	SQ-DT-P	172X	

The flash memory versions for each device are displayed.

On-Screen Display	Flash memory of Device
I / F	User IF microcomputer
MAIN	Main microcomputer
WID-PRG	Program for IC3, Boot program for IC3
WID-DAT	Extension Engin data for IC3
GUI-PRG	GUI data for IC3
MODULE	Module microcomputer
SEQ-PRG	Program for IC4
SQ-DT-V	Sequence data for IC4 (for VIDEO)
SQ-DT-P	Sequence data for IC4 (for PC)

Note : If the versions for MODULE and SEQ-PRG are -5*M, refer to this manual and PDP-504CMX : ORDER NO. ARP3242 for servicing. If it is -0*M, refer to PDP-504CMX : (ORDER NO. ARP3191, ARP3192), PDP-434CMX : (ORDER NO. ARP3198, ARP3199) for servicing.

2. VERSION (2)

1	2	3	4	5	6	7	8	9	10	11	12	13	14	15	16	17	18	19	20	21	22	23	24	25	26	27	28	29	30	31	32	33	34	35	36	37	38	39	40	
	I	N	F	O	R	M	A	T	I	O	N					I	N	1	-	G	3	2	-	R	G	B	-	4	M	X										
	V	E	R	S	I	O	N	(2)																														
	S	L	O	T	-	D	E	T								4	G																							

The type of video card inserted in the slot is displayed:

Device	Name Indication	Type of video card	Remarks
SLOT-DET	SLOT-DET	(No indication) 4G 5003B 4G 5004R 3G TYPE * 4G TYPE *	No card inserted When the Pioneer PDA-5003 Standard Video Card is inserted. When the Pioneer PDA-5004 Standard Video Card is inserted. When a PDP-503CMX-based OEM video card is inserted * = A to H When a PDP-504CMX-based OEM video card is inserted * = A to J

3. SERIAL

1	2	3	4	5	6	7	8	9	10	11	12	13	14	15	16	17	18	19	20	21	22	23	24	25	26	27	28	29	30	31	32	33	34	35	36	37	38	39	40		
	I	N	F	O	R	M	A	T	I	O	N					I	N	1	-	G	3	2	-	R	G	B	-	4	M	X											
	S	E	R	I	A	L																																			

The serial number of the product is displayed.

Note : If the 8th digit from the left in the serial number (_ _ _ CCSS100001JP) is 1, refer to this manual and PDP-504CMX : ORDER NO. ARP3242 for servicing. If it is 0, refer to PDP-504CMX : (ORDER NO. ARP3191, ARP3192), PDP-434CMX : (ORDER NO. ARP3198, ARP3199) for servicing.

4. PANEL PD

A

1	2	3	4	5	6	7	8	9	10	11	12	13	14	15	16	17	18	19	20	21	22	23	24	25	26	27	28	29	30	31	32	33	34	35	36	37	38	39	40
1	INFORMATION										IN1-G32-RGB-4MX																												
2																																							
3	PANEL PD																																						
4	FIRST										SECOND																												
5	1	X-DRV	POWER	00523	H51M																																		
6	2	Y-SUS	Y-DCDC	00275	H42M																																		
7	3	SCAN	---	00090	H50M																																		
8	4	Y-DCDC	POWER	00043	H03M																																		
9	5	SCN-5V	POWER	00002	H31M																																		
10	6	ADRS	---	00000	H07M																																		
11	7				H M																																		
12	8				H M																																		
13																																							
14																																							
15																																							
16																																							

The log of the past eight power-downs is displayed. Power-down points (first and second) and the hour meter value when the power-down was generated are displayed, with the latest power-down data at the top. The meanings of indications for power-down points are shown in the table below.

B

• Power-down information

Type of Power-down	On-Screen Display	Type of Power-down	On-Screen Display
No corresponding item	-----	Power-down of the Y-SUS system	Y-SUS
Power-down of the main power supply system	POWER	Power-down of the address system	ADRS
Power-down of the scanning system	SCAN	Power-down of the X-DRIVE circuitry	X-DRV
Power-down in the path between the scanning system and 5-V power supply	SCN-5V	Power-down of the X-DC/DC converter	X-DCDC
Power-down of the Y-Drive system	Y-DRV	Power-down of the X-SUS system	X-SUS
Power-down of the Y-DC/DC converter	Y-DCDC	Power-down of the driving IC power supply system	D-DCDC
PD which cannot be specified	UNKNOWN	Drive stop PD	-----

*1: If an activated protection circuit could not be identified after the power-down, it is treated as an unidentifiable power-down (UNKNOWN).

C

D

E

F

5. PANEL SD

1	2	3	4	5	6	7	8	9	10	11	12	13	14	15	16	17	18	19	20	21	22	23	24	25	26	27	28	29	30	31	32	33	34	35	36	37	38	39	40
INFORMATION																																							
IN1-G32-RGB-4MX																																							
PANEL SD																																							
MAIN																				SUB																			
1	AUDIO	----	00103	H51	M																																		
2	MA-IIC	VOLIC	00075	H42	M																																		
3	TEMP1	-----	00050	H50	M																																		
4				H	M																																		
5				H	M																																		
6				H	M																																		
7				H	M																																		
8				H	M																																		

The log of the past eight shutdowns is displayed. Shutdown points and the hour meter value when the shutdown was generated are displayed, with the latest shutdown data at the top.

The meanings of indications for shutdown points are shown in the table below.

• Panel shutdown information

No.	Type of Shutdown	On-Screen Display (MAIN)	Subcategory
1	Abnormality in IC4 communication	IC4	
2	Abnormality in module microcomputer IIC communication	MD-IIC	Exists.
3	DIGITAL-DCDC power decrease	RST2	
4	Abnormality in panel temperature	TEMP1	
5	Short-circuiting of the speakers	AUDIO	
6	Abnormality in module microcomputer communication	MODULE	
7	Abnormality in three-wire serial communication of the main microcomputer	MA-SRL	Exists.
8	Abnormality in main microcomputer IIC communication	MA-IIC	Exists.
9	Abnormality in main microcomputer communication	MAIN	
10	FAN stopped	FAN	
11	Abnormality in unit temperature	TEMP	Exists.
12	Abnormality in the ASIC power on the main microcomputer side	M-DCDC	
13	Other failures	ETC	Exists.

• Subcategory information

No.	Type of Shutdown	Subcategory
2	MD-IIC	EEPROM4K, EROM2K
7	MA-SRL	IF microcomputer, IC2, IC3
8	MA-IIC	MA-EEP, IC1-V, IC1-Y, AD-M, AD-S, SL-EEP, IC6/1, IC6/2, VOLIC
11	TEMP	INSIDE/AIR (INSIDE = TEMP2/AIR = TEMP3)
13	ETC	RLS, VCC-D1, VCC-D2

6. TEMPERATURE

A

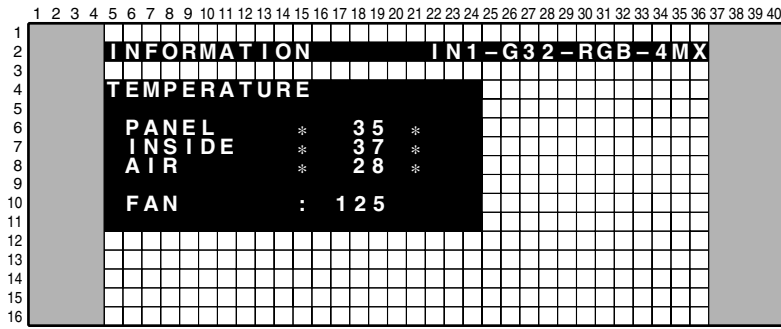

Data from each temperature sensor and the fan output value are displayed:

- Temperature sensors [°C]
 - PANEL: Sensor temperature of a panel part (Reference value)
 - INSIDE: Temperature inside the unit (Reference value)
 - AIR: Ambient temperature around the unit (Reference value)
- Fan output: Fan output data

To update the temperature values or fan output data, use the [◀] or [▶] key.

B

7. HOUR METER

C

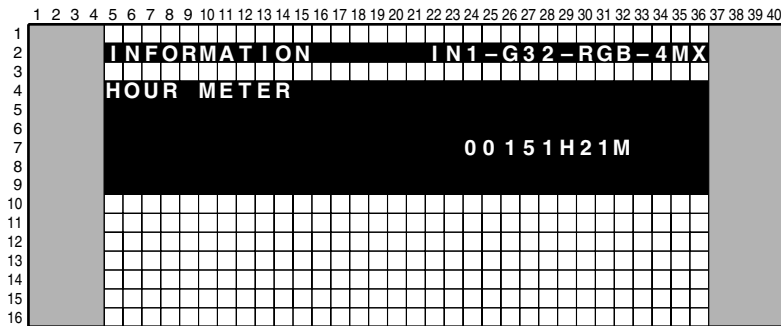

The cumulative power-on time is displayed.

8. PULSE METER

D

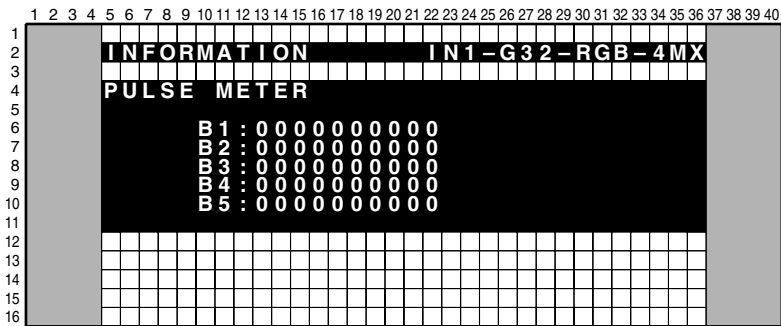

The cumulative number of pulses is displayed.

9. P ON COUNTER

E

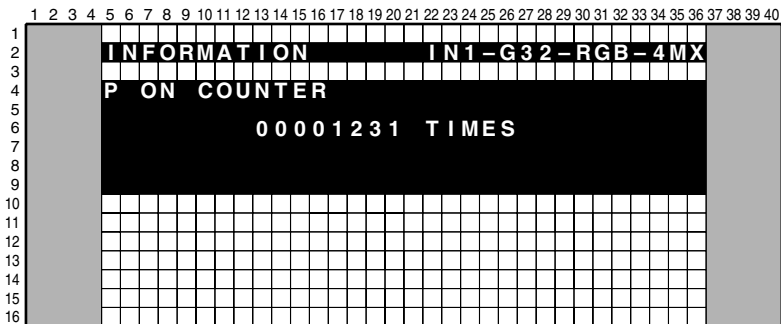

The cumulative number of times the unit was turned on is displayed.

F

10. BACKUP EEPROM

When the DIGITAL VIDEO Assy is to be replaced, the adjustment values in it are temporarily stored in the backup ROM then are written on the new Assy after replacement. (Refer to the "7.1.6 BACKUP THE ADJUSTMENT VALUES FOR THE MAIN UNIT".)

- ① Check if adjustment has been made on the DIGITAL VIDEO Assy or not (i.e., in the state of a new service part), and if the data on any adjustment values are retained in the backup ROM or not.

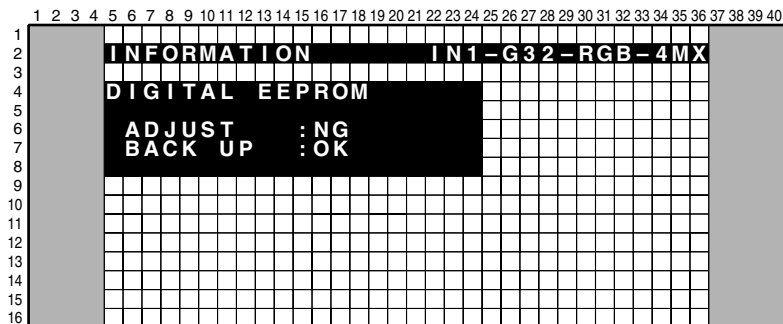

- ADJUST: OK (DIGITAL VIDEO Assy adjusted)
NG (DIGITAL VIDEO Assy not adjusted)
- BACKUP: OK (Adjustment data retained in the backup ROM)
NG (Adjustment data not retained in the backup ROM)

- ② Downloading the data for the DIGITAL VIDEO Assy from the backup ROM

- Press the SET key while display ① above is displayed, and the following display will appear.

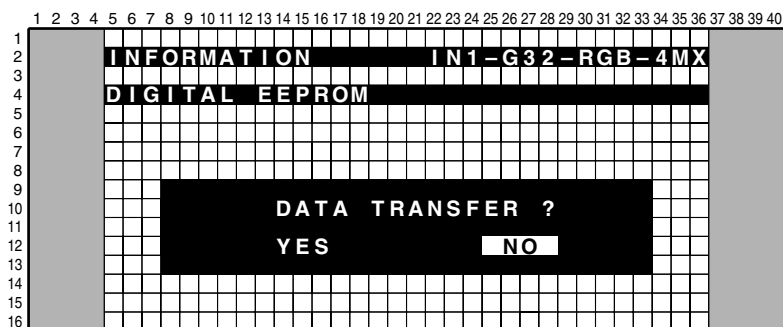

- Move the cursor to YES and press the SET key.
The data in the backup ROM are copy to the DIGITAL VIDEO Assy.
(When a new DIGITAL VIDEO Assy has been mounted, it now has the adjustment data suited for the panel.)
- Move the cursor to NO, and press the SET key.
Copy of the data to the DIGITAL VIDEO Assy will not be executed.

- ③ Clearing the data in the ROM of the DIGITAL VIDEO Assy

- When YES or NO is selected while display ② above is displayed, the following display will appear.

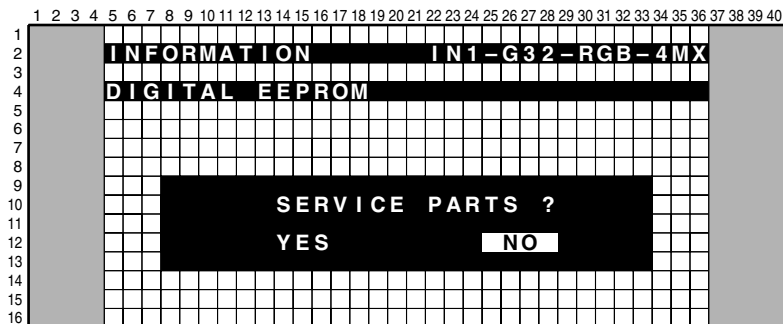

- Move the cursor to YES and press the SET key.
The data in the ROM of the DIGITAL VIDEO Assy are cleared, and the Assy has no specific adjustment data.
- Move the cursor to NO and press the SET key. The data in the ROM of the DIGITAL VIDEO Assy are not cleared.
When YES selected on display ② and the data were copy, select NO on this display.

Note: When YES or NO is selected on display ③ above, the display returns to that of ① above.

Adjustment of corresponding route unevenness

Basically, only replacement of service parts is required, and adjustment is not required.

No.	Command	Adjustment Parameter Name in Factory	Function
1	VSG	CVY GAIN	IC1 MAIN GAIN adjustment (switching routes with the SWM [main] and SWS [sub] commands)
2	VSO	CVY OFFSET	IC1 MAIN OFFSET adjustment (switching routes with the SWM [main] and SWS [sub] commands)
3	RYG	RY GAIN	AD R GAIN adjustment (correction in differences between component- and RGB-system signals)
4	GYG	GY GAIN	AD G GAIN adjustment (correction in differences between component- and RGB-system signals)
5	BYG	BY GAIN	AD B GAIN adjustment (correction in differences between component- and RGB-system signals)
6	ADC	AD MAIN GAIN	AD MAIN RGB GAIN adjustment (for main screen)
7	MRG	AD MAIN RY GAIN	AD MAIN RY GAIN adjustment (for main screen)
8	MGG	AD MAIN GY GAIN	AD MAIN GY GAIN adjustment (for main screen)
9	MBG	AD MAIN BY GAIN	AD MAIN BY GAIN adjustment (for main screen)
10	MRO	AD MAIN RY OFS	AD MAIN RY OFFSET adjustment (for main screen)
11	MGO	AD MAIN GY OFS	AD MAIN GY OFFSET adjustment (for main screen)
12	MBO	AD MAIN BY OFS	AD MAIN BY OFFSET adjustment (for main screen)
13	SRG	AD SUB RY GAIN	AD SUB RY GAIN adjustment (for sub screen)
14	SGG	AD SUB GY GAIN	AD SUB GY GAIN adjustment (for sub screen)
15	SBG	AD SUB BY GAIN	AD SUB BY GAIN adjustment (for sub screen)
16	SRO	AD SUB RY OFS	AD SUB RY OFFSET adjustment (for sub screen)
17	SGO	AD SUB GY OFS	AD SUB GY OFFSET adjustment (for sub screen)
18	SBO	AD SUB BY OFS	AD SUB BY OFFSET adjustment (for sub screen)

Reference: Commands for adjustment of differences in signals and memory cells used for storing adjustment values

- Basically no adjustment is required for the Service Assy, as it is properly adjusted before shipment.

Adjustment values to be stored in the EEPROM of the AV I/O (INDIVIDUAL mode)

Adjustment values differ depending on the input function, input signal format, and main/sub screen.

Input and Signal Format	Commands for Adjustment	
	Route for the Main Screen	Route for the Sub Screen
INPUT1 (RGB)	RYG GYG BYG	RYG GYG BYG
INPUT1 (Color difference)	RYG GYG BYG	RYG GYG BYG

- Four adjustment tables are provided here, depending on the input function, input signal format, and main/sub screen.
- No adjustment is required for INPUT 2, which is of DVI (digital video interface) standards.

Adjustment values to be stored in the EEPROM of the PDA-5003 or PDA-5004

Adjustment values differ depending on the input function and main/sub screen.

Input and Signal Format	Commands for Adjustment	
	Route for the Main Screen	Route for the Sub Screen
INPUT3 (Y/C)	VSG VSO	RYG GYG BYG
INPUT4 (Comp. V)	VSG VSO	RYG GYG BYG
INPUT5 (Y/C)	RYG GYG BYG	RYG GYG BYG
INPUT5 (Color difference)	RYG GYG BYG	RYG GYG BYG

- Eight adjustment tables are provided here, depending on the input function and main/sub screen.

Adjustment values to be stored in the EEPROM of the RGB (COMMON mode)

Adjustment values differ depending on the signal resolution, input signal format, and main/sub screen.

Note: No adjustment is required for DVI input or signals converted to digital signals by IC1.

[Main adjustment 1]

Main A/D adjustments for R, G, and B individually (COMMON-RGB mode)

Input and Signal Format	Commands for Adjustment		Conditions for the Tables to be Switched
525i (RGB)	MRG MGG MBG	MRO MGO MBO	Video RGB signals (excl. 1125p signals)
525i (Color difference)	MRG MGG MBG	MRO MGO MBO	Video color-difference signals (excl. 1125p signals)
1080p (RGB)	MRG MGG MBG	MRO MGO MBO	All PC signals and 1125p RGB signals
1080p (Color difference)	MRG MGG MBG	MRO MGO MBO	1125p color-difference signals

- For adjustment according to the above tables, input corresponding signals to INPUT 5 to change the RGB/color-difference signal setting then perform adjustment.
- Four adjustment tables are provided here, depending on the signal resolution, input signal format, and main/sub screen.

[Sub adjustment 1]

Main A/D adjustments for R, G, and B individually (COMMON-RGB 1 mode)

Input and Signal Format	Commands for Adjustment		Conditions for the Tables to be Switched
RGB	SRG SGG SBG	SRO SGO SBO	All R, G, and B signals
Color difference	SRG SGG SBG	SRO SGO SBO	All color-difference signals

- For adjustment according to the above tables, input video signals to INPUT 5 to switch to the route for sub input and to change the RGB/color-difference signal setting then perform adjustment.
- Two adjustment tables are provided here, depending on the signal format.

[Main adjustment 2]

Main A/D adjustments for all R, G, and B simultaneously (COMMON-RGB 2 mode)

Input and Signal Format	Commands for Adjustment	Conditions for the Tables to be Switched
RGB	ADC	All R, G, and B signals
Color difference	ADC	All color-difference signals

- For adjustment according to the above tables, input video signals to INPUT 5 to switch to the route for main input and to change the RGB/color-difference signal setting then perform adjustment.
- A contrast gain commits this adjustment command simultaneously three colors.
- Two adjustment tables are provided here, depending on the signal format.

INDIVIDUAL ADJ. mode

A

1	INDIVIDUAL ADJ.	IN1-013-NTV-4MX
2		
3		
4		
5		
6		
7		
8		
9		
10		
11		
12		
13		
14		
15	CVY GAIN<=>	: 1 2 8
16		

B

Each time the ▲ or ▼ key is pressed, the individual adjustment items are changed, as follows:

No.	Corresponding 232C Command	Function/Display	Content	Adjustable Range	Remarks
1	VSG	CVY GAIN<=> : ***	MICHAEL (IC6255) input GAIN adj.	064 to 191	Select a route with the command SWM (main) and the command SWS (sub).
2	VSO	CVY OFFSET<=> : ***	MICHAEL (IC6255) input OFFSET adj.	064 to 191	
3	RYG	RY GAIN<=> : ***	AD (IC6001 or IC6602) R input GAIN adj.	000 to 255	The memory tables for the RGB and component systems are separate, and are switchable with the command MCD.
4	GYG	GY GAIN<=> : ***	AD (IC6001 or IC6602) G input GAIN adj.	000 to 255	
5	BYG	BY GAIN<=> : ***	AD (IC6001 or IC6602) B input GAIN adj.	000 to 255	

"***" in the table above represents the adjustment value.

The value of each subitem can be changed using the ◀ or ▶ key.

C

Note: The differences in signals for the main and sublevel screens from the AV/IO Assy are compensated, and the compensation data are stored in the EEPROM (IC8705) for each screen.

COMMON ADJ. mode

D

1	COMMON ADJ.	IN1-G32-RGB-4MX
2		
3		
4		
5		
6		
7		
8		
9		
10		
11		
12		
13		
14		
15	RGB 1	
16		

Each time the ▲ or ▼ key is pressed, the subitems are changed, as follows:

- RGB1(+) : Adjustment of a video card and the RGB Assy
- RGB2(+) : Adjustment of the RGB Assy
- PANEL1(+) : Adjustment items related to the drive (common to the unit)
- PANEL2(+) : Adjustment items related to the drive (dependent on signals)

Each time the SET key is pressed, items grouped under the subitem are selected one by one.

F

1. COMMON-RGB1

1	2	3	4	5	6	7	8	9	10	11	12	13	14	15	16	17	18	19	20	21	22	23	24	25	26	27	28	29	30	31	32	33	34	35	36	37	38	39	40
1	COMMON-RGB1																							IN1-G32-RGB-4MX															
2																																							
3																																							
4																																							
5																																							
6																																							
7																																							
8																																							
9																																							
10																																							
11																																							
12																																							
13																																							
14																																							
15	AD MAIN R GAIN <=>																							: 128															
16																																							

Each time the ▲ or ▼ key is pressed, the subitems are changed, as follows:

When the main input is selected

No.	Corresponding 232C Command	Function/Display	Content	Adjustable Range	Remarks
1	MRG	AD MAIN R GAIN <=> :***	AD (IC6001) MAIN R GAIN adj. (for main screen)	000 to 255	
2	MGG	AD MAIN G GAIN <=> :***	AD (IC6001) MAIN G GAIN adj. (for main screen)	000 to 255	
3	MBG	AD MAIN B GAIN <=> :***	AD (IC6001) MAIN B GAIN adj. (for main screen)	000 to 255	
4	MRO	AD MAIN R OFFSET <=> :***	AD (IC6001) MAIN R OFFSET adj. (for main screen)	000 to 255	
5	MGO	AD MAIN G OFFSET <=> :***	AD (IC6001) MAIN G OFFSET adj. (for main screen)	000 to 255	
6	MBO	AD MAIN B OFFSET <=> :***	AD (IC6001) MAIN B OFFSET adj. (for main screen)	000 to 255	

When the sub input is selected

No.	Corresponding 232C Command	Function/Display	Content	Adjustable Range	Remarks
1	SRG	AD SUB R GAIN <=> :***	AD (IC6602) SUB R GAIN adj. (for sub screen)	000 to 255	
2	SGG	AD SUB G GAIN <=> :***	AD (IC6602) SUB G GAIN adj. (for sub screen)	000 to 255	
3	SBG	AD SUB B GAIN <=> :***	AD (IC6602) SUB B GAIN adj. (for sub screen)	000 to 255	
4	SRO	AD SUB R OFFSET <=> :***	AD (IC6602) SUB R OFFSET adj. (for sub screen)	064 to 191	
5	SGO	AD SUB G OFFSET <=> :***	AD (IC6602) SUB G OFFSET adj. (for sub screen)	064 to 191	
6	SBO	AD SUB B OFFSET <=> :***	AD (IC6602) SUB B OFFSET adj. (for sub screen)	064 to 191	

"***" in the table above represents the adjustment value.

The value of each subitem can be changed using the ◀ or ▶ key.

Note: The differences in signals for the main and sublevel screens from the RGB Assy are compensated, and the compensation data are stored in the EEPROM (IC7205) for each screen.

2. COMMON-RGB 2

1	2	3	4	5	6	7	8	9	10	11	12	13	14	15	16	17	18	19	20	21	22	23	24	25	26	27	28	29	30	31	32	33	34	35	36	37	38	39	40
1	COMMON-RGB2																							IN1-G32-RGB-4MX															
2																																							
3																																							
4																																							
5																																							
6																																							
7																																							
8																																							
9																																							
10																																							
11																																							
12																																							
13																																							
14																																							
15	AD MAIN CONTRAST <=>																							: 128															
16																																							

No.	Corresponding 232C Command	Function/Display	Content	Adjustable range	Remarks
1	ADC	AD MAIN CONTRAST<=> :***	AD (IC6001) MAIN RGB GAIN adj. (for main screen)	000 to 255	

"***" in the table above represents the adjustment value.

The value of each subitem can be changed using the ◀ or ▶ key.

3. COMMON-PANEL1

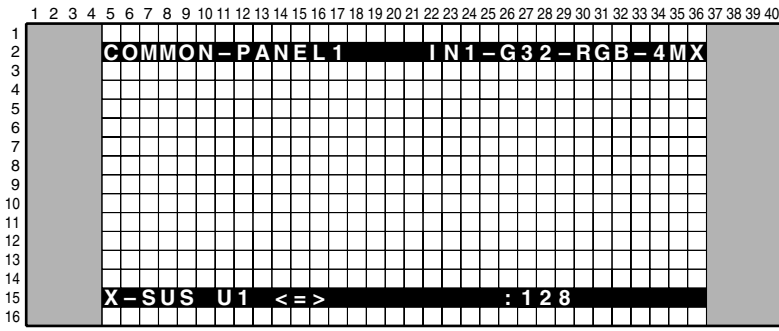

Each time the ▲ or ▼ key is pressed, the subitems are changed, as follows:

No.	Corresponding 232C Command	Function/Display	Content	Adjustable Range
1	XU1	X-SUS U1 <=> :***	Adjustment of X-SUS leading edge pulse U1	124 to 132
2	XU2	X-SUS U2 <=> :***	Adjustment of X-SUS leading edge pulse U2	124 to 132
3	XD1	X-SUS D1 <=> :***	Adjustment of X-SUS trailing edge pulse D1	124 to 132
4	XD2	X-SUS D2 <=> :***	Adjustment of X-SUS trailing edge pulse D2	124 to 132
5	YU1	Y-SUS U1 <=> :***	Adjustment of Y-SUS leading edge pulse U1	124 to 132
6	YU2	Y-SUS U2 <=> :***	Adjustment of Y-SUS leading edge pulse U2	124 to 132
7	YD1	Y-SUS D1 <=> :***	Adjustment of Y-SUS trailing edge pulse D1	124 to 132
8	YD2	Y-SUS D2 <=> :***	Adjustment of Y-SUS trailing edge pulse D2	124 to 132
9	YD3	Y-SUS D3 <=> :***	Adjustment of X-SUS trailing edge pulse D3	124 to 132
10	YD4	Y-SUS D4 <=> :***	Adjustment of X-SUS trailing edge pulse D4	124 to 132
11	VSU	VLT-SUS <=> :***	SUS voltage adjustment	000 to 255
12	VOF	VLT-OFS <=> :***	OFFSET voltage adjustment	000 to 255

"***" in the table above represents the adjustment value.

The value of each subitem can be changed using the ◀ or ▶ key.

Notes:

- Adjustments No. 1 to No. 10 above are not normally required, unless so instructed by Service Information, etc.
- Readjustment of values for No. 11 [VSU] and No. 12 [VOF] are required when the service panel is replaced.

4. COMMON-PANEL2

1	2	3	4	5	6	7	8	9	10	11	12	13	14	15	16	17	18	19	20	21	22	23	24	25	26	27	28	29	30	31	32	33	34	35	36	37	38	39	40
1	COMMON-PANEL 2																			IN1-G32-RGB-4MX																			
2																																							
3																																							
4																																							
5																																							
6																																							
7																																							
8																																							
9																																							
10																																							
11																																							
12																																							
13																																							
14																																							
15	PANEL R-HIGH <=>																			: 128 (PT1)																			
16																																							

Each time the ▲ or ▼ key is pressed, the subitems are changed, as follows:

No.	Corresponding 232C Command	Function/Display	Content	Adjustable Range
1	PRH	PANEL R HIGH <=> : *** (PTO)	Panel W/B R-HIGH adjustment	000 to 511
2	PGH	PANEL G HIGH <=> : *** (PTO)	Panel W/B G-HIGH adjustment	000 to 511
3	PBH	PANEL B HIGH <=> : *** (PTO)	Panel W/B B-HIGH adjustment	000 to 511
4	PRL	PANEL R LOW <=> : *** (PTO)	Panel W/B R-LOW adjustment	000 to 999
5	PGL	PANEL G LOW <=> : *** (PTO)	Panel W/B G-LOW adjustment	000 to 999
6	PBL	PANEL B LOW <=> : *** (PTO)	Panel W/B B-LOW adjustment	000 to 999
7	ABL	ABL LEVEL <=> : *** (ABx)	Power consumption adjustment	000 to 999

"***" in the table above represents the adjustment value.

The value of each subitem can be changed using the ◀ or ▶ key.

Note:

- White balance adjustment.(From No.1 to No.6). (Refer to 136 pages of the "[W/B-adjustment procedurs]")
- Adjustments No. 7: [ABL] above are not normally required, unless so instructed by Service Information, etc.

"(PTO)" and "(ABx)" in the table above represent the following:

Indication	Table
PT1	For PC and NTSC
PT2	For PAL, For PC (48Hz)

Indication	Table
AB1	For 60Hz and 75Hz video
AB2	For 50Hz video, For 48Hz PC
AB3	For PC

OPTION mode

1	2	3	4	5	6	7	8	9	10	11	12	13	14	15	16	17	18	19	20	21	22	23	24	25	26	27	28	29	30	31	32	33	34	35	36	37	38	39	40
1	OPTION																			IN1-G32-RGB-4MX																			
2																																							
3																																							
4																																							
5																																							
6																																							
7																																							
8																																							
9																																							
10																																							
11																																							
12																																							
13																																							
14																																							
15	PATTERN MASK (+)																																						
16																																							

Select the main item "OPTION" using the MUTE key then select the subitems shown in the table below using the ▲ or ▼ key.

No.	Function/Display	Content	Remarks
1	PATTERN MASK (+)	For selecting Pattern mask of IC4	A lower layer exists.
2	FULL MASK (+)	For selecting raster mask of IC4	A lower layer exists.
3	DYNAMIC RANGE	ON ⇔ OFF	The last setting is not stored in memory (initial setting: ON).
4	EDID WRITE MODE	DISABLE ⇔ ENABLE	The last setting is not stored in memory (initial setting: DISABLE).
5	INTEGRATOR MODE	DISABLE ⇔ ENABLE	Initial setting: ENABLE

Note:

- For PATTERN MASK (+) and FULL MASK (+), press the SET key to switch to the lower layer.
- Adjustments No. 3 to 5 above are not required for servicing.

1. PATTERN MASK

2. FULL MASK

A

	1	2	3	4	5	6	7	8	9	10	11	12	13	14	15	16	17	18	19	20	21	22	23	24	25	26	27	28	29	30	31	32	33	34	35	36	37	38	39	40				
1																																												
2																																												
3																																												
4																																												
5																																												
6																																												
7																																												
8																																												
9																																												
10																																												
11																																												
12																																												
13																																												
14																																												
15																																												
16																																												

To select the mask frequency, use the ◀ or ▶ key.

To select the mask pattern, use the ▲ or ▼ key.

Mask Frequency

No.	Corresponding RS-232C Command	Function/ Display	Content
1	F48	V48	Video 48-Hz sequence
2	F50	V50	Video 50-Hz sequence
3	F60	V60 (initial value)	Video 60-Hz sequence
4	F61	P60	PC 60-Hz sequence
5	F70	P70	PC 70-Hz sequence
6	F72	V72	Video 72-Hz sequence
7	F75	V75	Video 75-Hz sequence

Pattern Mask

No.	Corresponding RS-232C Command	Function/ Display	Content
1	M00	OFF	Mask mode: OFF
2	M01	01	White 0 to 100%
3	M02	02	Aging mask
4	M03	03	Aging mask (detection of still picture: OFF)
5	M10	10	H RAMP1
6	M11	11	H RAMP2
7	M12	12	H RAMP3
8	M13	13	H RAMP4
9	M14	14	V RAMP
10	M15	15	H/V RAMP
11	M20	20	Window0
12	M21	21	Window1
13	M22	22	Window2
14	M23	23	Window3
15	M24	24	Window4
16	M25	25	Window5
17	M26	26	Window6
18	M27	27	Window7
19	M28	28	Window8
20	M29	29	Window9
21	M2E	2E	Wiper for erasing afterimage
22	M30	30	COLOR BAR
23	M31	31	Slanted lines

Full Mask

No.	Corresponding RS-232C Command	Function/ Display	Content
1	M00	OFF	Mask mode: OFF
2	M51	51	Raster – White
3	M52	52	Raster – Red
4	M53	53	Raster – Green
5	M54	54	Raster – Blue
6	M55	55	Raster – Black
7	M56	56	Raster – Cyan
8	M57	57	Raster – Magenta
9	M58	58	Raster – Yellow
10	M59	59	Raster – Cyan 274
11	M60	60	Raster – 50 fresh color
12	M61	61	Raster – 50 purple
13	M62	62	Raster – 50 sky blue
14	M63	63	Raster – Red 779
15	M64	64	Raster – Cyan 218
16	M65	65	Raster – Cyan 448
17	M66	66	Raster – 43 fresh color
18	M67	67	Raster – Red 640
19	M68	68	Raster – Magenta 98
20	M69	69	Raster – 43 sky blue 1
21	M70	70	Raster – 43 sky blue 2
22	M71	71	Raster – 43 purple
23	M72	72	Raster – Blue 960
24	M73	73	Raster – Yellow 512
25	M74	74	Raster – Gray 512

3. DYNAMIC RANGE

The setting can be changed using the ◀ or ▶ key.

No.	Corresponding RS-232C Command	Function/ Display	Content
1	DYY	ON	DYNAMIC RANGE correction: ON (initial setting)
2	DYN	OFF	DYNAMIC RANGE correction: OFF

4. EDID WRITE MODE

The setting can be changed using the ◀ or ▶ key.

No.	Corresponding RS-232C Command	Function/ Display	Content
1	EWN	DISABLE	Prohibiting writing EDID data (initial setting)
2	EWY	ENABLE	Enabling writing EDID data

5. INTEGRATOR MODE

The setting can be changed using the ◀ or ▶ key.

No.	Corresponding RS-232C Command	Function/Display	Content
1	–	ENABLE	Permitting INTEGRATOR MODE (initial setting)
2	–	DISABLE	Prohibiting INTEGRATOR MODE

INITIALIZE mode

	1	2	3	4	5	6	7	8	9	10	11	12	13	14	15	16	17	18	19	20	21	22	23	24	25	26	27	28	29	30	31	32	33	34	35	36	37	38	39	40		
1																																										
2																																										
3																																										
4																																										
5																																										
6																																										
7																																										
8																																										
9																																										
10																																										
11																																										
12																																										
13																																										
14																																										
15																																										
16																																										

The subitems can be changed using the ▲ or ▼ key.

No.	Corresponding RS-232C Command	Function/Display	Content
1	–	SYNC DET (+)	(Not used)
2	–	DRIVE MODE (+)	(Not used)
3	–	SIDE MASK LEVEL (+)	(Not used)
4	–	PANEL REVICE (+)	(Not used)
5	FST	FINAL SETUP	For initializing user's settings and some factory settings
6	–	C TEMP LOW (+)	For adjusting the user's C TEMP MODE item selected
7	–	C TEMP MID LOW (+)	
8	–	C TEMP STD (+)	
9	–	C TEMP MID HIGH (+)	
10	–	C TEMP HIGH (+)	
11	–	C TEMP MODE2 (+)	(Not used)
12	–	SLOT PROTECT<=>	For setting permission/prohibition of SLOT

Note: Any item followed by (+) has a lower layer to which you can switch using the SET key.

1. FINAL SETUP

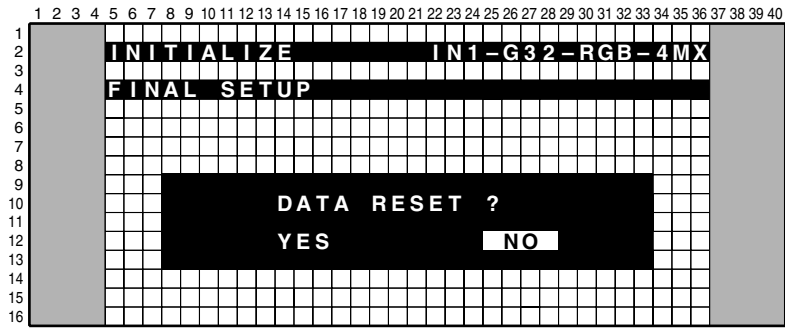

Select YES or NO using the ◀ or ▶ key then press the SET key for finalizing the selection:

YES : For executing FINAL SETUP

NO : For not executing FINAL SETUP

In FINAL SETUP, the following items can be initialized:

	Item (operation)	Factory setting	Remarks
Normal	Input function (main)	INPUT1	
	Input function (sub)	INPUT2	
	Screen size	VIDEO WIDE or FULL PC DOT BY DOT or FULL or 4:3 or PARTIAL	The screen-size setting will be one of the factory-preset values, based on the results of signal-type detection (SIG-MODE).
	Volume	0	
	Multi screen	OFF	
	FUNCTIONAL LOCK	LOCK OFF	
Menu setting	PICTURE	Default setting for all adjustment items	For each input function
	SCREEN	Default setting for all adjustment items	For each input function
	POWER MANAGEMENT	OFF	For each input function
	AUTO POWER OFF	DISABLE	For each input function
	COLOR TEMP.	MIDDLE	For each input function
	DNR	MIDDLE	For each input function
	MPEG NR	LOW	For each input function
	CTI	ON	For each input function
	PURECINEMA	OFF	For each input function
	COLOR DECODING	COMPONENT 1 or COMPONENT 2	One of the factory-preset signals is output, based on the results of signal-type detection (SIG-MODE) for the input function.
	CLAMP POSITION	AUTO	For each input function
	COLOR SYSTEM	AUTO	For each input function
	SIGNAL FORMAT	VGA or XGA or SXGA or 720-PC *	One of the factory-preset signals is output, based on the results of signal-type detection (SIG-MODE) for the input function.
	LANGUAGE	ENGLISH	
	ENERGY SAVE	STANDARD	
	SCREEN MGT.	OFF/ 01H00M	
	ORBITER	OFF	
MASK CONTROL	ON		
AUTO SET UP MODE	INACTIVE		
AUTO FUNCTION	OFF		
AUDIO OUT	FIXED		

* 720-PC selectable only with video card is inserted

	Item (operation)	Factory setting	Remarks	
A	Integrator menu setting	PICTURE	Default setting for all adjustment items	
		WHITE BAL.	Default setting for all adjustment items	
		SCREEN	Default setting for all adjustment items	
		GRADATION	VIDEO DRE MID PC GAMMA 2.0	The screen-size setting will be one of the factory-preset values, based on the results of signal-type detection (SIG-MODE).
		BRT. ENHANCE	OFF	For each input function
		SUB VOLUME	20	For each input function
		SCREEN MGT. SET	00H10M/00H30M/WHITE/ 00H10M/INV.1/1	
		SCREEN MASK	OFF	
	B		SIDE MASK	NORMAL/80/80/80
			2x2 MODE	OFF/UP LEFT/NORMAL
			MIRROR MODE	OFF
			BAUD RATE	9600BPS
			ID NO. SET	--
			OSD	ON
			FRONT INDICATOR	ON
			FAN CONTROL	AUTO
		COLOR MODE	NORMAL	
		PRO USE	OFF/OFF/DISABLE/ MOTION	
C		FRC	MODE1	
	Factory	PATTERN MASK	OFF	
		FULL MASK	OFF	
EDIT WRITE MODE		DISABLE		
232C	LOUDNESS	OFF		

2. C TEMP

1	2	3	4	5	6	7	8	9	10	11	12	13	14	15	16	17	18	19	20	21	22	23	24	25	26	27	28	29	30	31	32	33	34	35	36	37	38	39	40
1	INIT-CT-MID H																			IN1-G32-RGB-JHS																			
2																																							
3																																							
4																																							
5																																							
6																																							
7																																							
8																																							
9																																							
10																																							
11																																							
12																																							
13																																							
14																																							
15	R HIGH <=>																			: 1 2 8																			
16																																							

The indication on the 2nd line in the above display varies according to the subitem selected in the upper layer, as follows:
INIT-CT- ****

****: LOW/MID L/STD/MID H/HIGH/MOD2

Notes: Adjustments are not normally required, unless so instructed by Service Information, etc.

Each time the ▲ or ▼ key is pressed, items grouped under the subitems are changed, as follows:

No.	Function/Display	Content
1	R HIGH <=>	For adjusting R highlight in the selected color temperature mode
2	G HIGH <=>	For adjusting G highlight in the selected color temperature mode
3	B HIGH <=>	For adjusting B highlight in the selected color temperature mode
4	R LOW <=>	For adjusting R lowlight in the selected color temperature mode
5	G LOW <=>	For adjusting G lowlight in the selected color temperature mode
6	B LOW <=>	For adjusting B lowlight in the selected color temperature mode

To change the value of each item, press the ◀ or ▶ key.

3. SLOT PROTECT

Option No.	Function/Display	Operation/Control	Result of Distinction			
			PDA-5002	PDA-5003 PDA-5004	3G-TYPE * (* A - H)	4G-TYPE * (* A - J)
1 (initial setting)	ALL	Permitting all Video card	×	○	○	○
2	P-SLOT	Permitting only the Video card (PDA-5003/ PDA- 5004) made by Pioneer	×	○	×	×

○: Operable according to the setting ×: The corresponding Video card will be treated as an incompatible Video card.

- When a disallowed video card is inserted, the power is not turned on, and the red and green LEDs flash alternatively.
- For details on results of distinction, see "SLOT-DET of the VERSION (2)."

6.5 COMMAND DESCRIPTION

About GET Command

Operation description of GET command

Conditions under which GET commands are enabled

Most of the GET commands are enabled at any time, regardless of unit's being on/off or in Factory or Normal mode. However, some GET commands must be issued while the power is on to acquire correct data.

[Operations]

- Reading out and sending various data stored in the EEPROMs and the RAMs of microcomputers
- Adding a received string of command characters at the beginning of reply data as an echoback
- Decimal notation are converted into ASCII numerics and transmitted.
- CS is 2 bytes, to be interpreted as ASCII codes for 2 hexadecimal digits. These are the low-order 2 bytes of the total value of "receive command + transmission data" (except STX and ETX).

Reply data format

STX	Received command (3byte)	Transmission data	...	Transmission data	CS (2byte)	ETX
-----	--------------------------	-------------------	-----	-------------------	------------	-----

Example: [02] GAS 2 ... 0 97 [03]

GST: GET STATUS

Order	Data	Size	Remarks
1	Display data	3 byte	See the table below.
2	Power data	3 byte	See the table below. (The third character is for the subinput.)
3	Input function data (main)	3 byte	Input data during GST reception (INPUTs 1 to 5 are indicated as IN 1-5.)
4	Input function data (sub)	3 byte	Subinput data during GST reception (INPUTs 1 to 5 are indicated as IS 1-5.)
5	Screen size data	1 byte	See the table below.
6	Two-screen indication	1 byte	0: OFF (Full-screen) 1: 2-SCREEN 2: PinP (Lower right) 3: PinP (Upper right) 4: PinP (Upper left) 5: PinP (Lower left) 6: PoutP
7	FUNCTIONAL LOCK data	1 byte	0: LOCK OFF 1: BUTTONS LOCK 2: IR LOCK 3: IR&BUTTONS LOCK 4: MEMORY LOCK
8	Dummy data	3 byte	(Three-digit figure)
9	Temperature data 2 (TEMP2)	3 byte	°C (Not.1)
10	Temperature data 3 (TEMP3)	3 byte	°C (Not.2)
11	Serial	15 byte	(Not.4)
12	Dummy data	3 byte	(Three-digit figure)
13	Dummy data	3 byte	
14	HOUR METER data	5 byte	Indicated in hours
15	Dummy data	2 byte	(Checksum)

Display data	1st character 2nd character 3rd character	Data on generation: 4 (Fixation) Data on screen size: 4 (43 inches), 5 (50 inches) Data on destination: M (Fixation)
Power data	1st character 2nd character 3rd character	Power status and signal status PN (power on & at usually, of signal Input), PL (power on & no input), PO (power on & out of range signal Input), SN (stand by/ on), SW (power management standby), SS (SD and PD standby), Multi screen features. The sub signal state of a input (see Note. 2) N (at usually, of signal Input), L(no Input), O (out of range in signal Input)
Screen size data	1st character	Numbers used are the same as those that indicate SIG-MODE screen sizes. 0: Dot by Dot PARTIAL, 1: 4:3, 2: FULL or FULL1080i, 3: ZOOM, 4: WIDE, 6: CINEMA, 8: FULL1035i, 9: UNDERSCAN

Not.1: During Standby or immediately after the power is turned on, accurate temperature data cannot be obtained.

To obtain an accurate temperature reading, wait for a few minutes after the power is turned on.

Not.2: During Standby or full-screen display, dummy data (symbols) are output.

Not.3: During Standby or full-screen display, values stored in memory of the unit are output.

Not.4: See "3. SERIAL" on page 97 for details on the serial data.

GS1: Returning information on the model and the version of the software

Order	Data	Size
1	Data on the display	3 byte
2	Version of the module microcomputer	4 byte
3	Version of the IC4-MANTA	4 byte
4	Sequence version (50VIDEO)	4 byte
5	Sequence version (50PC)	4 byte
6	Sequence version (43VIDEO)	4 byte
7	Sequence version (43PC)	4 byte
8	Version of the IF microcomputer	4 byte
9	Version of the main microcomputer	4 byte
10	Version of the IC3-MANTA	4 byte
11	Version of the OSD	4 byte
12	Dummy	12 byte

Breakdown of the data on the display

Data	Model
MX5	PDP-504CMX series
MX4	PDP-434CMX series

GPW: RGB-level-related adjustment values of the panel system

Order	Data	Size
1	Panel W/B table currently used	3 byte
2	Main contrast	4 byte
3	Red high light of the W/B adjustment value	4 byte
4	Green high light of the W/B adjustment value	4 byte
5	Blue high light of the W/B adjustment value	4 byte
6	Main brightness	4 byte
7	Red low light of the W/B adjustment value	4 byte
8	Green low light of the W/B adjustment value	4 byte
9	Blue low light of the W/B adjustment value	4 byte

Data	Table
PT1	WB table for NTSC
PT2	WB table for PAL
PT3	Reserved table

GPD: Power-down information

Order	Data	Size	Order	Data	Size
1	Latest "1st PD" data	1 byte	17	Fifth latest "1st PD" data	1 byte
2	Latest "2nd PD" data	1 byte	18	Fifth latest "2nd PD" data	1 byte
3	Data of hour meter for the latest PD	7 byte	19	Data of hour meter for the fifth latest PD	7 byte
4	Data on temperature for the latest PD (TEMP1)	3 byte	20	Data on temperature for the fifth latest PD (TEMP1)	3 byte
5	Second latest "1st PD" data	1 byte	21	Sixth latest "1st PD" data	1 byte
6	Second latest "2nd PD" data	1 byte	22	Sixth latest "2nd PD" data	1 byte
7	Data of hour meter for the second latest PD	7 byte	23	Data of hour meter for the sixth latest PD	7 byte
8	Data on temperature for the second latest PD (TEMP1)	3 byte	24	Data on temperature for the sixth latest PD (TEMP1)	3 byte
9	Third latest "1st PD" data	1 byte	25	Seventh latest "1st PD" data	1 byte
10	Third latest "2nd PD" data	1 byte	26	Seventh latest "2nd PD" data	1 byte
11	Data of hour meter for the third latest PD	7 byte	27	Data of hour meter for the seventh latest PD	7 byte
12	Data on temperature for the third latest PD (TEMP1)	3 byte	28	Data on temperature for the seventh latest PD (TEMP1)	3 byte
13	Fourth latest "1st PD" data	1 byte	29	Eighth latest "1st PD" data	1 byte
14	Fourth latest "2nd PD" data	1 byte	30	Eighth latest "2nd PD" data	1 byte
15	Data of hour meter for the fourth latest PD	7 byte	31	Data of hour meter for the eighth latest PD	7 byte
16	Data on temperature for the fourth latest PD (TEMP1)	3 byte	32	Data on temperature for the eighth latest PD (TEMP1)	3 byte

Hour meter data; 1 to 5 byte: time, 6 to 7 byte: minute

• Details on "1st/2nd PD" data

Data	Power-down Point
0	No power-down
1	Not used (for MR-POWER)
2	P-POWER
3	SCAN
4	SCN-5V
5	Y-DRIVE
6	Y-DCDC
7	Y-SUS
8	ADRS
9	X-DRIVE
A	X-DCDC
B	X-SUS
C	DIG-DCDC
D	Drive processing IC (IC4)
E	Spare
F	Power-down point not identified

GNG: NG history

Order	Data	Size	Order	Data	Size
1	Latest SD data	1 byte	17	Fifth latest SD data	1 byte
2	Data of subcategory for the latest SD	1 byte	18	Data of subcategory for the fifth latest SD	1 byte
3	Data of hour meter for the latest SD	7 byte	19	Data of hour meter for the fifth latest SD	7 byte
4	Data on temperature for the latest SD	3 byte	20	Data on temperature for the fifth latest SD	3 byte
5	Second latest SD data	1 byte	21	Sixth latest SD data	1 byte
6	Data of subcategory for the second latest SD	1 byte	22	Data of subcategory for the sixth latest SD	1 byte
7	Data of hour meter for the second latest SD	7 byte	23	Data of hour meter for the sixth latest SD	7 byte
8	Data on temperature for the second latest SD	3 byte	24	Data on temperature for the sixth latest SD	3 byte
9	Third latest SD data	1 byte	25	Seventh latest SD data	1 byte
10	Data of subcategory for the third latest SD	1 byte	26	Data of subcategory for the seventh latest SD	1 byte
11	Data of hour meter for the third latest SD	7 byte	27	Data of hour meter for the seventh latest SD	7 byte
12	Data on temperature for the third latest SD	3 byte	28	Data on temperature for the seventh latest SD	3 byte
13	Fourth latest SD data	1 byte	29	Eighth latest SD data	1 byte
14	Data of subcategory for the fourth latest SD	1 byte	30	Data of subcategory for the eighth latest SD	1 byte
15	Data of hour meter for the fourth latest SD	7 byte	31	Data of hour meter for the eighth latest SD	7 byte
16	Data on temperature for the fourth latest SD	3 byte	32	Data on temperature for the eighth latest SD	3 byte

Hour meter data; 1 to 5 byte: time, 6 to 7 byte: minute

• Details on the SD data

Data	Cause of Shutdown
0	No abnormality
1	IC4
2	Module microcomputer IIC
3	Abnormality in DIG-RST2 (power decrease of ASIC)
4	Panel having abnormally high temperature
5	Audio failure (short-circuiting of the speakers)
6	Communication failure of the module microcomputer
7	Three-wire serial communication failure of the main microcomputer
8	IIC communication failure of the main microcomputer
9	Communication failure of the main microcomputer
A	Fan stopped
B	Temperature abnormality
D	Abnormality in MAIN-RST2
F	Others

• Data on the subcategories for the module microcomputer IIC

Data	Cause of Shutdown
0	No subcategory
1	EEPROM (4k) (IC5206)
2	EEPROM (2k) (IC7102)

• Data on the subcategories for failure in 3-wire serial communication of the main microcomputer

Data	Cause of Shutdown
0	No subcategory
1	Communication failure of the IF microcomputer
2	IC2 communication failure (IC7004)
3	IC3 communication failure (IC7101)

• Data on the subcategories for failure in IIC communication of the main microcomputer

Data	Cause of Shutdown
0	No subcategory
1	EEPROM (128k) (IC7205)
2	Not used
3	IC1 main (IC6107)
4	IC1 sub (IC6255)
5	AD-PLL main (IC6001)
6	AD-PLL sub (IC6602)
7	IC6 (IC5701)
8	Not used
9	Not used
A	Not used
B	Not used
C	Not used
D	Not used
E	Not used
F	EEPROM (SLOT) (IC6257)
G	Not used
H	Not used
N	IC6/2 (CMX) (IC5801)

• Subcategory data on abnormal temperature

Data	Cause of Shutdown
2	Temperature inside the unit (INSIDE)
3	Ambient temperature (AIR)

• Subcategory data on other failures

Data	Cause of Shutdown
1	Optical sensor (RLS)
2	Power monitor 1 (VCC-D1)
3	Power monitor 1 (VCC-D2)

GS2: Status information

Order	Data	Size	Remarks
1	Notifying of switching to Standby mode	1 byte	1: Successfully switched to Standby mode
2	Whether the unit has already been adjusted or not	1 byte	0: Adjusted, 1: Not adjusted
3	With/without backup of adjustment data	1 byte	0: With backup, 1: Without backup
4	Power-down information	2 byte	1st byte: 1st PD, 2nd byte: 2nd PD
5	Temperature information (TEMP1)	3 byte	000 to 255
6	Abnormality in RST2 (power decrease of the DC-DC converter)	1 byte	0: Normal, 1: Shutdown process caused by an abnormality completed, 2: In the process of displaying a warning against shutdown caused by an abnormality
7	IC4 communication failure	1 byte	
8	EEPROM communication failure	1 byte	
9	Failure in audio	1 byte	
10	Communication failure of the volume IC	1 byte	
11	Backup-ROM communication failure	1 byte	
12	Failure in temperature information (TEMP1)	1 byte	
13	Activation of panel protection	1 byte	0: Panel protection not activated, 1: Panel protection being activated
14	(Reservation)	2 byte	* *
15	Accumulated hour meter data cleared (Note 1)	7 byte	1-5 bytes: Hours, 6-7 bytes: Minutes
16	Hour meter data (clearable) (Note 2)	7 byte	1-5 bytes: Hours, 6-7 bytes: Minutes

* Ignore the 2-byte checksum at the end.

* Data to be used for servicing may be item 5 (temperature data) and 15 and 16 (hour meter data).

Note 1 : The data are updated each time the hour meter data are cleared. The total value of data items 15 and 16 indicates accumulated power-on time after shipment. Data item 15 cannot be cleared with a command.

Note 2 : The hour meter data indicated on the Factory menu are displayed. The data represent accumulated power-on time of the panel after the last clearance of hour meter data. At shipment, the data are reset to 0.

• Power-down information

Data	Power-down point
0	No power-down
1	Not used
2	P-POWER
3	SCAN
4	SCN-5V
5	Y-DRIVE
6	Y-DCDC
7	Y-SUS
8	ADRS
9	X-DRIVE
A	X-DCDC
B	X-SUS
C	DIG-DCDC
D	Drive processing IC (IC4)
E	Reservation
F	Power-down point not identified

GPM: Value of the pulse meter

Order	Data	Size
1	Pulse meter (Block area 1)	10 byte
2	Pulse meter (Block area 2)	10 byte
3	Pulse meter (Block area 3)	10 byte
4	Pulse meter (Block area 4)	10 byte
5	Pulse meter (Block area 5)	10 byte

Note:

The number of electric discharges at each block is displayed. The first digit represents the number of tens of thousands.

[Location of the block areas from which values from the pulse meter are obtained]

Block ①															
0	1	2	3	4	5	6	7	8	9	10	11	12	13	14	15
16	17	18	19	20	21	22	23	24	25	26	27	28	29	30	31
32	33	34	35	36	37	38	39	40	41	42	43	44	45	46	47
48	49	50	51	52	53	54	55	56	57	58	59	60	61	62	63
64	65	66	67	68	69	70	71	72	73	74	75	76	77	78	79
80	81	82	83	84	85	86	87	88	89	90	91	92	93	94	95
96	97	98	99	100	101	102	103	104	105	106	107	108	109	110	111
112	113	114	115	116	117	118	119	120	121	122	123	124	125	126	127
128	129	130	131	132	133	134	135	136	137	138	139	140	141	142	143
144	145	146	147	148	149	150	151	152	153	154	155	156	157	158	159
160	161	162	163	164	165	166	167	168	169	170	171	172	173	174	175
176	177	178	179	180	181	182	183	184	185	186	187	188	189	190	191
192	193	194	195	196	197	198	199	200	201	202	203	204	205	206	207
208	209	210	211	212	213	214	215	216	217	218	219	220	221	222	223
224	225	226	227	228	229	230	231	232	233	234	235	236	237	238	239
240	241	242	243	244	245	246	247	248	249	250	251	252	253	254	255
Block ②															
Block ③															
Block ④															
Block ⑤															

GPC: Number of times the power was turned on

Order	Data	Size
1	Power-on counter	8 byte

GAJ: Drive-related adjustment values

Order	Data	Size
1	ABL table currently used	3 byte
2	Upper limit of the power	3 byte
3	Vsus adjustment value	3 byte
4	Vofs adjustment value	3 byte
5	X-SUS-U1 adjustment value (XU1)	3 byte
6	X-SUS-U2 adjustment value (XU2)	3 byte
7	X-SUS-D2 adjustment value (XD2)	3 byte
8	X-SUS-D1 adjustment value (XD1)	3 byte
9	Y-SUS-U1 adjustment value (YU1)	3 byte
10	Y-SUS-U2 adjustment value (YU2)	3 byte
11	Y-SUS-D1-2 adjustment value (YD2)	3 byte
12	Y-SUS-D1-1 adjustment value (YD1)	3 byte
13	Y-SUS-D2-2 adjustment value (YD4)	3 byte
14	Y-SUS-D2-1 adjustment value (YD3)	3 byte

Data	Table
AB1	ABL table for NTSC
AB2	ABL table for PAL, ABL table for PC (48Hz)
AB3	ABL table for PC

LIST OF RS-232C COMMAND

Command	Operation	Validity of Direct Numeric Input	Lower limit	Upper limit	Remarks
[A]					
ABL	Adjusting power consumption	○	000	255	
ADC	AD CONTRAST adjustment	○	000	255	
AMN	Audio MUTE OFF				
AMY	Audio MUTE ON				
AST	Execution of auto setup				The values for positions are not stored in memory in Factory mode.
[B]					
BCP	Transmitting the backup data to the DIGITAL VIDEO Assy				
BRA	Indicate a current baudrate				
BRAS01	Setting the UART to 232C (1200 bps)				
BRAS02	Setting the UART to 232C (2400 bps)				
BRAS03	Setting the UART to 232C (4800 bps)				
BRAS04	Setting the UART to 232C (9600 bps)				
BRAS05	Setting the UART to 232C (19200 bps)				
BRAS06	Setting the UART to 232C (38400 bps)				
BYG	Adjusting BY GAIN	○	000	255	
[C]					
CNG	MR NG INFORMATION CLEAR				
CPC	Clearing the power-on counter				
CPD	Clearing power-down information				
[D]					
DIN	Turning off the on-screen display				Prohibit OSD indication
DIY	Turning on the on-screen display				While the DIY command is in force, the duration of OSD is unlimited.
DOF	Erasing the currently displayed indications				If another command is received, an OSD is displayed.
DRF	Turning off the power for the drive system				Return to the DRN state by turning the power off
DRN	Turning on the power for the drive system				
DW0	Decreasing the adjustment value by 10				
DWn	Decreasing the adjustment value by n (n=1 to 9)				
DWF	Minimizing the adjustment value				
DYN	No D-range correction				
DYY	With D-range correction				
[E]					
EWN	Prohibiting writing of EDID data				
EWY	Permitting writing of EDID data				
[F]					
F48	Video 48-Hz sequence				
F50	Video 50-Hz sequence				
F60	Video 60-Hz sequence				
F61	PC 60-Hz sequence				
F70	PC 70-Hz sequence				
F72	Video 72-Hz sequence				
F75	Video 75-Hz sequence				
FAJ	Determining the adjustment flag of the DIGITAL VIDEO Assy in "adjustment is completed"				
FAN	Turning Service Factory mode off				The OSD equivalent to that usually displayed when the power is turned on is displayed.
FAY	Turning Service Factory mode on				
FCA	Turning fan roll control to auto				
FCM	Maximizing the fan roll control				
FST	Executing FINAL SETUP				
FXO	Selecting audio output fixing				
[G]					
GAJ	Obtaining the adjustment values for the panel				
GMM	Switching the gamma	○	000	007	
GNG	Obtaining the shutdown information				

Command	Operation	Validity of Direct Numeric Input	Lower limit	Upper limit	Remarks
GNP	Obtaining the serial no.				
GPC	Obtaining the P ON COUNTER value				
GPD	Obtaining power-down information				
GPM	Obtaining the PULSE METER data				
GPP	Obtaining the PD polling log				
GPW	Obtaining the PANEL W/B data				
GS1	Obtaining the version data for each device				
GS2	Obtaining the temperature data and unit state				Data of module microcomputer system
GS4	Obtaining Factory information				
GST	Obtaining the temperature data and unit state				Data of main microcomputer system
GYG	FY GAIN	○	000	255	
[H]					
HMD	Indicating the hour meter				
[I]					
IDC	Clearing the ID				
IDS	Setting the ID	○	(00)	(FF)	
IN1	Switching the main screen to Input 1				
IN2	Switching the main screen to Input 2				
IN3	Switching the main screen to Input 3				
IN4	Switching the main screen to Input 4				
IN5	Switching the main screen to Input 5				
INP	Indicating the input function of current main screen				
INPS01	Switching the main screen to Input 1				
INPS02	Switching the main screen to Input 2				
INPS03	Switching the main screen to Input 3				
INPS04	Switching the main screen to Input 4				
INPS05	Switching the main screen to Input 5				
[L]					
LNN	Prohibiting LOUDNESS				
LNY	Permitting LOUDNESS				
[M]					
M00	Mask mode: OFF				
M01	White: 0 to 100%				
M02	Aging mask				
M03	Aging mask (detection of still picture: OFF)				
M10	RAMP slant 1				
M11	RAMP slant 4				
M12	RAMP slant 1 shifting				
M13	RAMP slant 4 shifting				
M14	V RAMP				
M15	H/V RAMP				
M20	WINDOW-Low: 102 / High: 870				
M21	WINDOW-Low: 102 / High: 1023				
M22	WINDOW-Low: 0 / High: 1023				
M23	WINDOW-High: 1023 (CENTER)				
M24	WINDOW-PEAK WINDOW				
M25	WINDOW-1/7 vertical window				
M26	WINDOW-magenta/green stripe				
M27	WINDOW-green/magenta stripe				
M28	Window (black & white [1 x 8], checkered pattern [for EMG check])				
M29	Window (for W/B adjustment, magenta, yellow)				
M2E	Wiper to prevent phosphor burn				
M2F	Warning mask of cable disconnection (Red and green light alternately)				
M30	COLOR BAR				
M31	Slanted lines				
M51	Raster-white				

Command	Operation	Validity of Direct Numeric Input	Lower limit	Upper limit	Remarks
M52	Raster-red				
M53	Raster-green				
M54	Raster-blue				
M55	Raster-black				
M56	Raster-cyan				
M57	Raster-magenta				
M58	Raster-yellow				
M59	Raster-cyan 274				
M60	Raster-50 flesh color				
M61	Raster-50 light purple				
M62	Raster-50 sky blue				
M63	Raster-red 779				
M64	Raster-cyan 218				
M65	Raster-cyan 448				
M66	Raster-43 flesh color				
M67	Raster-red 640				
M68	Raster-magenta 98				
M69	Raster-43 sky blue 1				
M70	Raster-43 sky blue 2				
M71	Raster-43 light purple				
M72	Raster-blue 960				
M73	Raster-yellow 200				
M74	Raster-gray 511 (spare)				
MBG	AD MAIN B GAIN	○	000	255	
MBO	AD MAIN B OFFSET	○	000	255	
MCD	Indicating the current color decoding				
MCDS01	Setting the color decoding to RGB (VIDEO)				
MCDS02	Setting the color decoding to COMPONENT1 (YCbCr)				
MCDS03	Setting the color decoding to COMPONENT2 (YPbPr)				
MGG	AD MAIN G GAIN	○	000	255	
MGO	AD MAIN G OFFSET	○	000	255	
MRG	AD MAIN R GAIN	○	000	255	
MRO	AD MAIN R OFFSET	○	000	255	
MTN	Turning the video mute off				
MTY	Turning the video mute on				
[N]					
NGN	Prohibiting shutdown operation				No writing of the latest data
[P]					
PAF	PEAK LIMITER OFF				
PAN	PEAK LIMITER ON				
PBH	Panel W/B B-HIGH adjustment	○	000	511	
PBL	Panel W/B B-LOW adjustment	○	000	999	
PDN	Do not pass a PD signal through the POWER SUPPLY Unit				
PDY	Pass a PD signal through the POWER SUPPLY Unit				
PGH	Panel W/B G-HIGH adjustment	○	000	511	
PGL	Panel W/B G-LOW adjustment	○	000	999	
PMD	Indicating the pulse meter				
POF	Turning the power OFF				
PRH	Panel W/B R-HIGH adjustment	○	000	511	
PRL	Panel W/B R-LOW adjustment	○	000	999	
[R]					
RYG	RY GAIN	○	000	255	
[S]					
SBG	AD SUB B GAIN	○	000	255	
SBO	AD SUB B OFFSET	○	064	191	
SFT	Indicating the current signal format				

Command	Operation	Validity of Direct Numeric Input	Lower limit	Upper limit	Remarks
SFTS01	Setting the signal format to PC FORMAT1 (VGA or XGA or SXGA or 720-PC)				
SFTS02	Setting the signal format to PC FORMAT2 (WVGA or WXGA or SXGA+)				
SFTS03	Setting the signal format to (VIDEO) 525p or 750p				
SFTS04	Setting the signal format to PC AUTO				
SGG	AD SUB G GAIN	○	000	255	
SGO	AD SUB G OFFSET	○	064	191	
SN0	Setting 1, 2, or 3 for the serial number of the panel				
SN1	Setting 4, 5, or 6 for the serial number of the panel				
SN2	Setting 7, 8, or 9 for the serial number of the panel				
SN3	Setting 10, 11, or 12 for the serial number of the panel				
SN4	Setting 13, 14, or 15 for the serial number of the panel				
SRG	AD SUB R GAIN	○	000	255	
SRO	AD SUB R OFFSET	○	064	191	
SVL	Adjusting the sub volume	○	000	020	
SWM	Full-screen display of main output				
SWN	Main/sub displays OFF				
SWS	Full-screen display of sub output				
SZM	Indicating the current screen size setting				
SZMS00	Setting the screen size to Dot by Dot or PARTIAL				
SZMS01	Setting the screen size to 4:3				
SZMS02	Setting the screen size to FULL or FULL1080i				
SZMS03	Setting the screen size to ZOOM				
SZMS04	Setting the screen size to CINEMA				
SZMS05	Setting the screen size to WIDE				
SZMS06	Setting the screen size to FULL1035i				
[U]					
UAJ	Determining the adjustment flag of the DIGITAL VIDEO Assy in "adjustment is completed"				
UP0	Increasing the adjustment value by 10				
UPn	Increasing the adjustment value by n (n=1 to 9)				
UPF	Maximizing the adjustment value				
[V]					
VOF	Offset voltage adjustment	○	000	255	
VOL	Adjusting the audio volume	○	000	045	
VRO	Selecting the variable audio output				
VSG	CVY GAIN	○	064	191	
VSO	Adjusting the CV/YC input with difference in the input	○	000	255	
VSU	SUS voltage adjustment	○	000	255	
[X]					
XD1	D1 trailing-edge pulse of X-SUS	○	000	255	
XD2	D2 trailing-edge pulse of X-SUS	○	000	255	
XU1	U1 leading-edge pulse of X-SUS	○	000	255	
XU2	U2 leading-edge pulse of X-SUS	○	000	255	
[Y]					
YD1	D1 trailing-edge pulse of Y-SUS	○	000	255	
YD2	D2 trailing-edge pulse of Y-SUS	○	000	255	
YD3	D3 trailing-edge pulse of Y-SUS	○	000	255	
YD4	D4 trailing-edge pulse of Y-SUS	○	000	255	
YU1	U1 leading-edge pulse of Y-SUS	○	000	255	
YU2	U2 leading-edge pulse of Y-SUS	○	000	255	

6.6 METHOD FOR REPLACING THE SERVICE PANEL ASSY

The following adjustments and operations are required when the Panel Assy is replaced for servicing.

A ■ Adjustments of the V_{sus} and V_{ofs} voltages

Input the reference adjustment values that are described on the service panel for the V_{sus} and V_{ofs} voltages, with the RS232C commands or on the Factory menu.

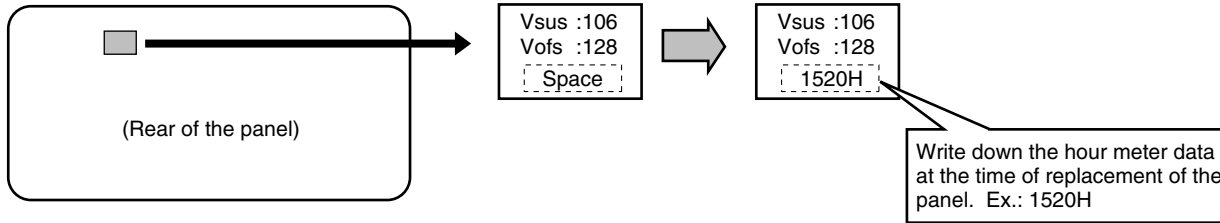

B • With the RS232C commands

Input the adjustment values described on the label attached to the rear of the panel:

- Reference adjustment of the V_{sus} voltage : [VSU***] Ex. : [VSU106]
- Reference adjustment of the V_{ofs} voltage : [VOF***] Ex. : [VOF128]

• On the Factory menu

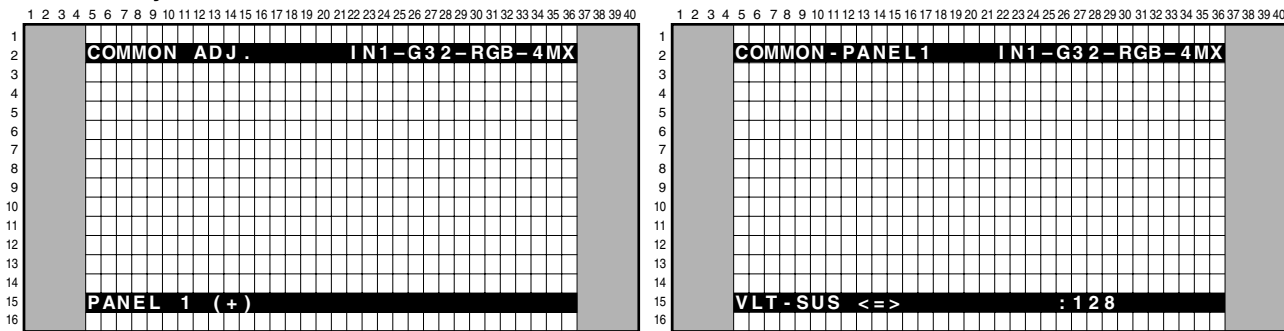

Using the MUTE key, select the main item "COMMON ADJ." Select the subitem "PANEL 1" then "VLT-SUS" or "VLT-OFS," using the ▲ or ▼ key and SET key. Enter the value, using the ◀ or ▶ key.

■ Clearing various logs for the panel, such as that for the hour meter

It is necessary to clear various logs, such as that for the hour meter, to match the driving hours of the panel before and after replacement. Write down the hour-meter data at the time of replacement of the panel on the label attached to the rear of the panel.

Notes: • For clearing, use the RS232C commands or the Factory menu.

• With the RS232C commands

You can obtain the accumulated power-on time data of the product itself with the "GS2" RS232C command. (See "6.5 Command description".)

- 1 For clearing the hour meter (for the panel) : CHM
- 2 For clearing the pulse meter : CPM
- 3 For clearing the shutdown (SD) log : CSD
- 4 For clearing the power-down (PD) log : CPD

• On the Factory menu

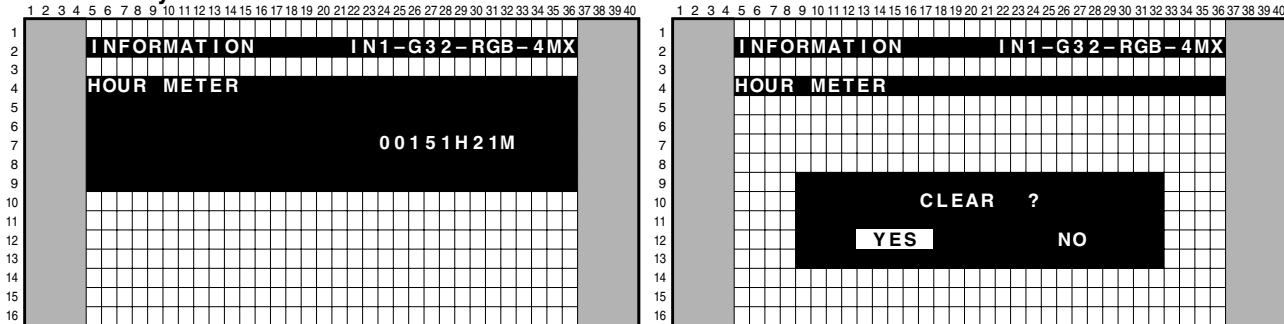

Using the MUTE key, select the main item "INFORMATION." Select the subitem "HOUR METER," using the ▲ or ▼ key and SET key. Clear the hour-meter data.

In the same way, select the subitem "PULSE METER," "PANEL SD," or "PANEL PD" under the main item "INFORMATION" then clear the data.

7. GENERAL INFORMATION

7.1 DIAGNOSIS

7.1.1 CONFIGURATION OF THE PC BOARD

Note : This illustration is 50 inch model.

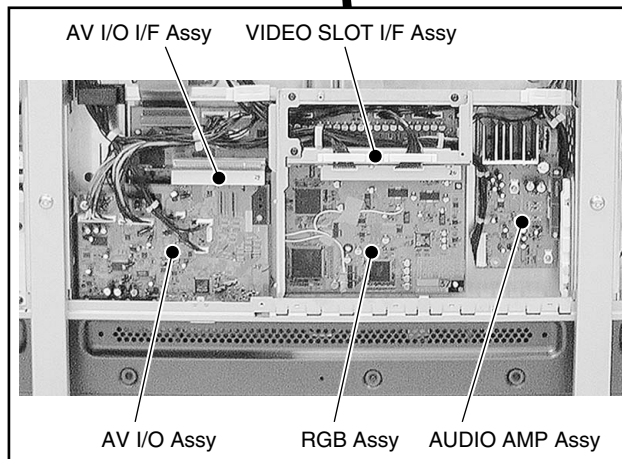
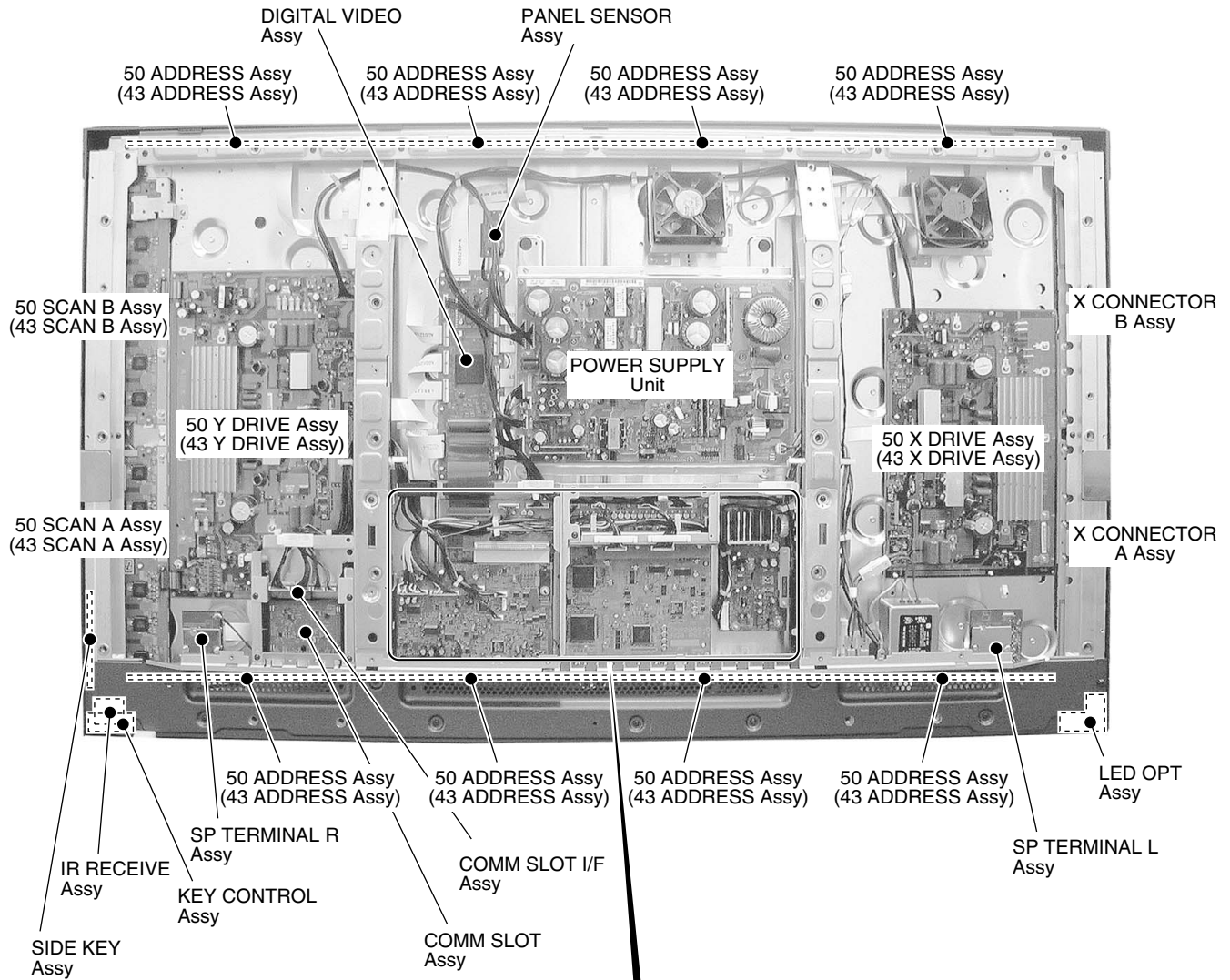

● Rear view

7.1.2 DIAGNOSIS FOR SHUTDOWN AND POWER-DOWN BY LED

• Operation statuses indicated by LEDs

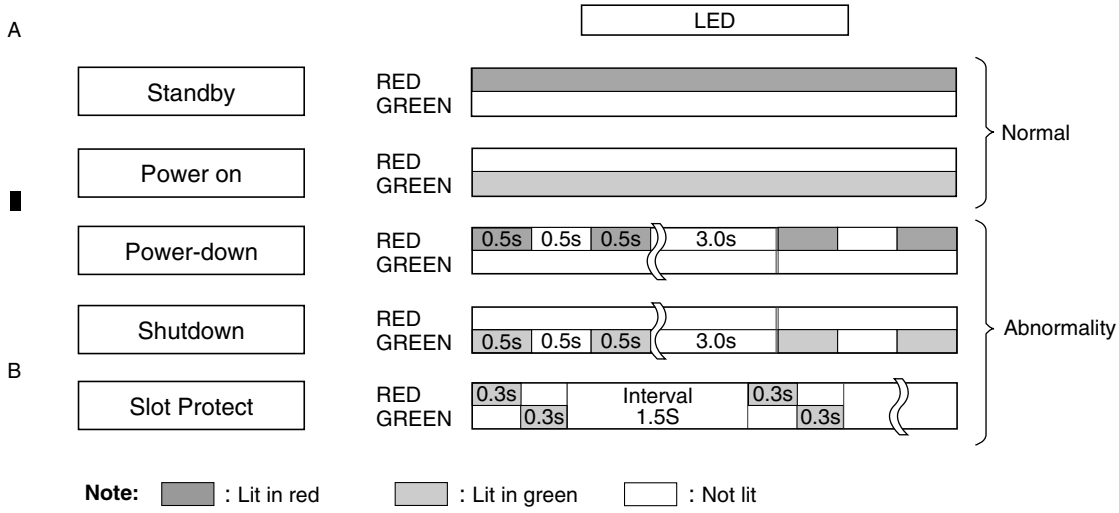

• Identification of locations having abnormality by the number of times the LEDs flash

■ On Shutdown and power-down

Shutdown

- Operation: When the microcomputer detects any abnormality, it forcibly shuts the unit off.
- LED indication: The LED flashes in green.

Note: The LED flashes regardless of the FRONT INDICATOR setting on the Integrator menu.

Power-down

- Operation: When the unit is in emergency status, a protection circuit is activated, and the power is shut off.
- LED indication: The LED flashes in red.

Category	LED		Content	Unit's Operation	Warning Message						
	STB	ON									
SD		Once	Communication failure of the panel-drive IC	Shutdown 3 seconds after warning	Shutdown by circuit failure (01)						
		Twice	Communication failure of the module IIC	Shutdown 3 seconds after warning	Shutdown by circuit failure (02)						
		3 times	Power decrease of the digital DC-DC converter	Immediate shutdown							
		4 times	Panel having high temperature	Shutdown 30 seconds after warning	Shutdown by warning temperature rise (04)						
		5 times	Audio failure	Shutdown 3 seconds after warning	Shutdown by warning speaker failure (05)						
		6 times	Communication failure of the module microcomputer	Shutdown 3 seconds after warning	Shutdown by circuit failure (06)						
		7 times	Main 3-wire serial communication in failure	Shutdown 3 seconds after warning	Shutdown by circuit failure (07)						
		8 times	Communication failure of the main IIC	Shutdown 3 seconds after warning	Shutdown by circuit failure (08)						
		9 times	Communication failure of the main microcomputer	Immediate shutdown							
		10 times	Fan in failure	Shutdown 3 seconds after warning	Shutdown by warning fan abnormality (10)						
		11 times	Unit having higher temperature	Shutdown 30 seconds after warning	Shutdown by warning temperature rise (11)						
		13 times	Main microcomputer ASIC power supply NG	Immediate shutdown							
		14 times	Communication failure of IF-EEPROM	Shutdown 3 seconds after warning	Shutdown by circuit failure (14)						
		15 times	Other failure	<table border="1"> <tr> <td>RLS</td> <td>Shutdown 30 seconds after warning</td> <td rowspan="3">Shutdown by circuit failure (15)</td> </tr> <tr> <td>VCC-D1</td> <td>Shutdown 3 seconds after warning</td> </tr> <tr> <td>VCC-D2</td> <td>Shutdown 3 seconds after warning</td> </tr> </table>	RLS	Shutdown 30 seconds after warning	Shutdown by circuit failure (15)	VCC-D1	Shutdown 3 seconds after warning	VCC-D2	Shutdown 3 seconds after warning
	RLS	Shutdown 30 seconds after warning	Shutdown by circuit failure (15)								
VCC-D1	Shutdown 3 seconds after warning										
VCC-D2	Shutdown 3 seconds after warning										
PD	Once										
	Twice		Power	Immediate power-down							
	3 times		SCAN	Immediate power-down							
	4 times		SCAN-5V	Immediate power-down							
	5 times		Y-DRIVE	Immediate power-down							
	6 times		Y-DCDC	Immediate power-down							
	7 times		Y-SUS	Immediate power-down							
	8 times		ADDRESS	Immediate power-down							
	9 times		X-DRIVE	Immediate power-down							
	10 times		X-DCDC	Immediate power-down							
	11 times		X-SUS	Immediate power-down							
	12 times		DIGITAL-DCDC	Immediate power-down							
	15 times		UNKNOWN (Not identified)*1 Drive processing IC (IC4)*2	Immediate power-down							

*1: If the unit cannot identify which protection circuit was activated, even if a power-down had been detected, the red LED may flash 15 times.

*2: If 15 times blink of a power-down cannot be specified, the drive processing IC exists.

See "4.PANEL PD" on page 98 and "GPD: Power-down information" on page 116.

Block diagram of the shutdown signal system

Note:

The figures ① - ⑮ indicate the number of times the LED flashes when shutdown occurs in the corresponding route.

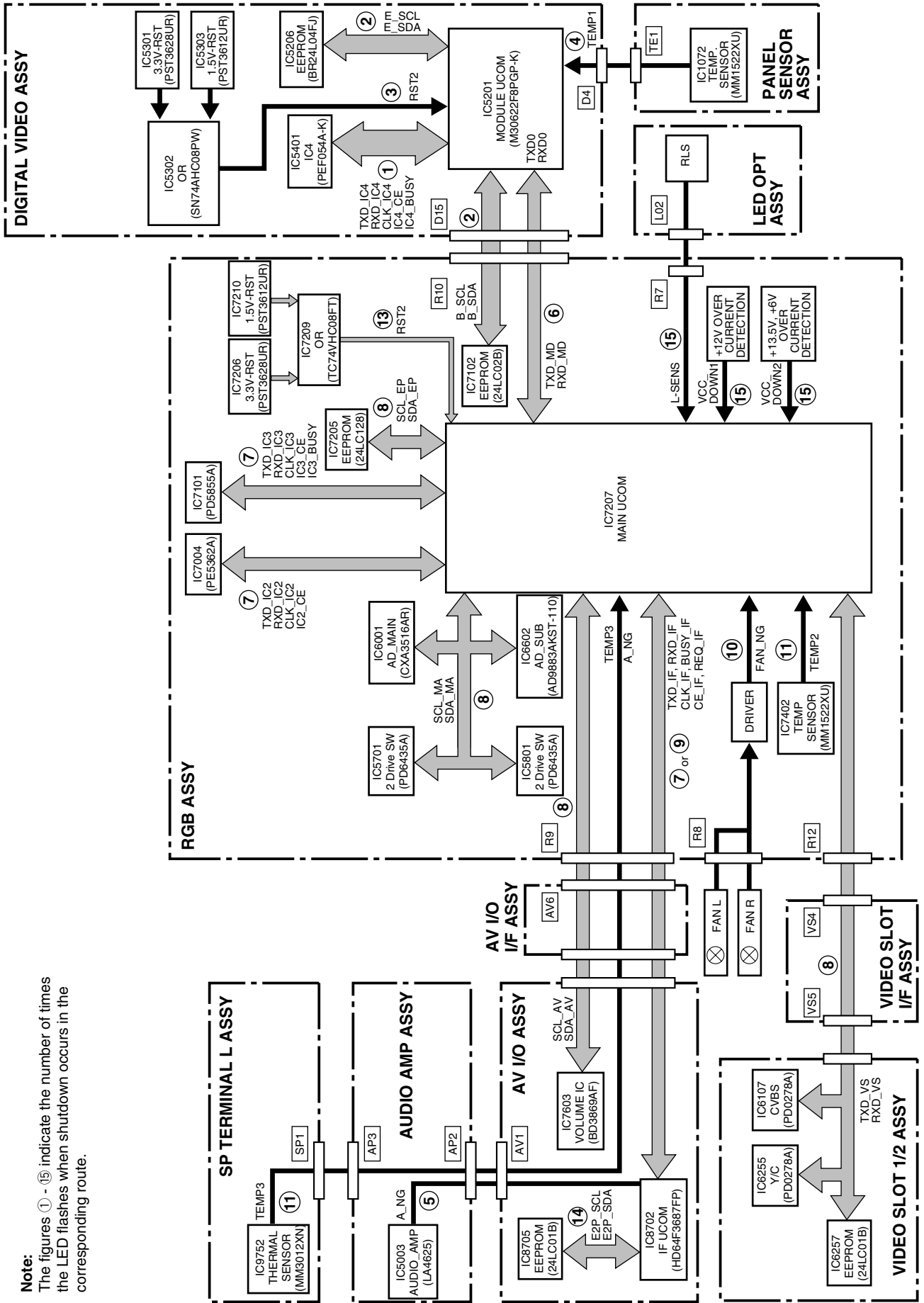

• Diagnosis of shutdown

	SD Circuit in Operation	Defective Assy	Reason for Shutdown	Point to be Checked	Possible Defective Part	Remarks
1	Communication failure of the panel-drive IC	DIGITAL VIDEO	Communication failure of IC4 or defective peripheral circuits	IC4 Block, Panel Flash Block	IC5401, IC5305	After turning the unit on again, check if the data on the version can be read with the GST command.
2	Communication failure of the module IC (Check the shutdown subcategory on the Factory menu.)	DIGITAL VIDEO RGB	Communication failure of the EEPROM (4k) or defective peripheral circuits Communication failure of the EEPROM (2k) or defective peripheral circuits	Module Ucom Block IC3 Block	IC5206 IC7102	
3	Power decrease of DIGITAL-DC-DC	DIGITAL VIDEO DIGITAL VIDEO POWER SUPPLY	Defective 114-pin FPC Defective DC-DC converter Defective RST IC No startup of 12 V	CN400(D15) - CN7101(R10) Digital DD Control Block Panel Flash Block	ADY1081 U5601 IC5301, IC5302, IC5303	Check if the cable is disconnected or not securely connected. Check if 3.3V, 2.5V, and 1.5V are activated (not short-circuited).
4	Panel having higher temperature	DIGITAL VIDEO	Disconnection of cable Panel having higher temperature	CN5202 - CN1071 Surrounding temperature		Temperature detected by a sensor must not exceed 90°C (TEMP1).
5	Audio failure	AUDIO AMP AUDIO AMP	Speaker short-circuited Defective AMP IC Disconnection of cable	Speaker terminals Audio Amp CN7601(AV1) - CN5001(AP2)	IC5003	Check if the speaker cables are in contact with the chassis, etc.
6	Communication failure of the module microcomputer	DIGITAL VIDEO	Communication failure in the module microcomputer or defective peripheral circuits Failure in writing in the module microcomputer	Module Ucom Block Module Ucom Block	IC5201 IC5201	Check if the cable is disconnected or not securely connected. Check short/open of the communication line (TXDO/RXDO).
7	Serial communication failure of the 3-wire of the main microcomputer	AV I/O RGB RGB RGB VIDEO SLOT1 or 2 VIDEO SLOT1 or 2 RGB RGB RGB RGB AV I/O RGB VIDEO SLOT1 or 2	Defective 114-pin FPC Communication failure in the IF microcomputer or defective peripheral circuits Communication failure in the CELIA or defective peripheral circuits Communication failure in the MIKE or defective peripheral circuits Failure in writing in the MIKE Failure in MICHAEL Y/C or defective peripheral circuits Failure in MICHAEL CVBS or defective peripheral circuits Failure in AD MAIN or defective peripheral circuits Failure in AD SUB or defective peripheral circuits Failure in ROZ or defective peripheral circuits Failure in ROZ or defective peripheral circuits Failure in VOL IC or defective peripheral circuits Failure in EEPROM or defective peripheral circuits Failure in EEPROM or defective peripheral circuits Defective communication line between any of the above devices and the main microcomputer	IF Ucom Block IC2 Block IC3 Block IC3 Block IC1 (Y/C) Block IC1 (CVBS) Block Main AD Block Sub LPF & AD Block Bus SW1 Block Bus SW2 Block AV I/O Assy Main Ucom Block IC1 (Y/C) Block	IC5201 ADY1081 IC8702 IC7004 IC7101 IC7101 IC6255 IC6107 IC6001 IC6602 IC5701 IC5801 IC7603 IC7205 IC6257 IC7207	Check if the cable is disconnected or not securely connected. Check short / open of the communication line (TXD_IF/RXD_IF/CLK_IF/BUSY_IF/CE_IF) Check short / open of the communication line (TXD_IC2/RXD_IC2/CLK_IC2/CE_IC2) Check short / open of the communication line (TXD_IC3/RXD_IC3/CLK_IC3/BUSY_IC2/CE_IC3)
8	IIC communication failure of the main microcomputer (Confirm the SD subcategory in the factory menu)	RGB RGB AV I/O RGB VIDEO SLOT1 or 2	Failure in writing in the MIKE Failure in MICHAEL Y/C or defective peripheral circuits Failure in MICHAEL CVBS or defective peripheral circuits Failure in AD MAIN or defective peripheral circuits Failure in AD SUB or defective peripheral circuits Failure in ROZ or defective peripheral circuits Failure in ROZ or defective peripheral circuits Failure in VOL IC or defective peripheral circuits Failure in EEPROM or defective peripheral circuits Failure in EEPROM or defective peripheral circuits Defective communication line between any of the above devices and the main microcomputer	IC3 Block IC1 (Y/C) Block IC1 (CVBS) Block Main AD Block Sub LPF & AD Block Bus SW1 Block Bus SW2 Block AV I/O Assy Main Ucom Block IC1 (Y/C) Block	IC6257 IC7207	Check short / open of SCL_AV/SDA_AV, SCL_MA/SDA_MA and SCL_EP/SDA_EP

SD Circuit in Operation	Defective Assy	Reason for Shutdown	Point to be Checked	Possible Defective Part	Remarks
9	RGB	Communication failure in main microcomputer or defective peripheral circuits	Main Ucom Block	IC7207	Check short / open of communication line (TXD_IF/RXD_IF/CLK_IF/BUSY_IF/CE_IF/REQ_IF)
10	RGB	Failure in writing in the main microcomputer	Main Ucom Block	IC7207	
	FAN	Failure in the fan motor or fan stopped by attached dust			Check if the cable is disconnected or not securely connected.
11	RGB	Disconnection of cable	Relay part between CN7402 (R8) and the wire from the fan		Temperature detected by a sensor must not exceed 65°C (TEMP3) /95°C (TEMP2)
	AUDIO AMP	Use under high temperature	Surrounding/internal		Check if the cable is disconnected or not securely connected.
14	AV I/O	Disconnection of cable	CN5003(AP3) - CN9702(SP1)		Check short / open of E2P_SCL/E2P_SDA
	Communication failure in IF EEPROM	Communication failure in EEPROM or defective peripheral circuits	I/F Ucom Block	IC8705	
15	RGB	Disconnection of cable	CN9051(L0) - CN7205(R7)		Check if the cable is disconnected or not securely connected.
	VCC-D1	Defective circuits in the 12V system			Check for shortcircuits in the 12V system.
	VCC-D2	Defective circuits in the 13.5V and 6.5V systems.			Check for shortcircuits in the 13.5V and 6.5V systems.

• Diagnosis of abnormalities other than shutdown and power-down

Symptoms	Defective Assy	Abnormal Summary	Point to be Checked	Possible Defective Part	Remarks
No power (LED unit)		Disconnection of cable	CN7404		Check if the connection between the POWER SUPPLY and RGB assemblies is properly made.
	POWER SUPPLY	STB 3.3 V not started	CN7404(AV1)-11 pin		
No power (The LED remains lit in red and does not light in green.)	AV I/O	Defective IF microcomputer	I/F Ucom Block	IC8702	Check if the oscillation is normal (X8701 = 32 kHz, X8702 = 9.8 MHz) and if RESET is set to H (IC8703).
	RGB	Defective main microcomputer	Main Ucom Block	IC7207	If communication with the main microcomputer fails approx. 20 seconds after the AC power is on, the main microcomputer may be defective.
Key input not effective	RGB	Disconnection of cable	CN4801 - CN9002 CN9001 - CN8702		Check if the cables are not connected or securely connected.
	IR RECEIVE	Disconnection of cable	CN4901 - CN8901		Check if the cable is not connected or securely connected.
Remote control unit not effective	IR RECEIVE	Defective IR receiver section	IR	U4901	Check if a pulse is output when the key corresponding to Pin 3 of the CN4901 is pressed.
	DIGITAL VIDEO ADDRESS	Defective IC4	IC4 Block	IC5401	Check if an abnormal area in the screen changes when the FPC connected to the address corresponding to the abnormal area is replaced with the one corresponding to the next address.
Abnormal screen (Data of every other dot are abnormal)					Check that an abnormal area in the screen does not change when the FPC connected to the address corresponding to the abnormal area is replaced with the one corresponding to the next address.
		Defective 114-pin FPC	CN7101 - CN5001	ADY1081	Check if the FPC is broken or not securely connected.

• Block diagram of the power-down signal system

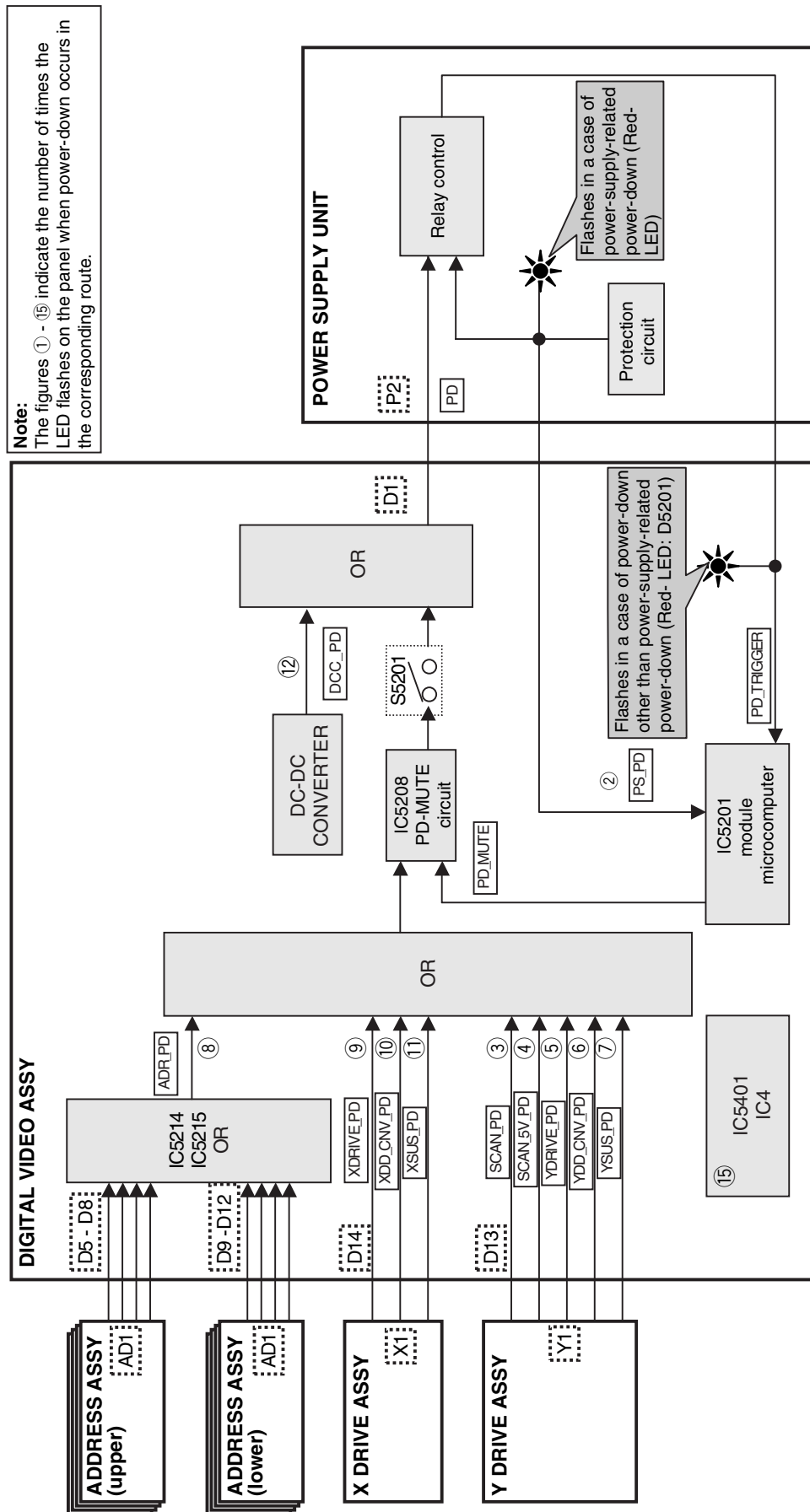

• Power-down diagnosis (defective points)

Note: 50 (43) *** Assy means (50 *** Assy or 43 *** Assy.)

PD Circuit in operation	Defective Assy	Reason for Power-down	Point to be Checked	Possible Defective Part	Remarks
2 POWER	POWER SUPPLY Unit				If the elapsed time from relay-on until the LED in the power supply unit lights is about 2~4 seconds, the defective assembly may be the 50 (43) X or Y DRIVE.
	50 (43) X DRIVE Assy	VSUS UVP	X SUS BLOCK	IC1203, IC1207 (mask module)	
3 SCAN	50 (43) Y DRIVE Assy	VSUS UVP	Y SUS BLOCK	IC2303, IC2307 (mask module)	
	50 (43) SCAN A, B Assy or 50 (43) Y DRIVE	VH UVP	SCAN IC	SCAN IC	
		VH UVP	VH DC/DC	IC2401, IC2402, IC2410, L2401	
		VH OVP	VH DC/DC	IC2402, IC2410	
		Disconnection of cable detected	CN2001, CN2301		
4 SCN-5V	50 (43) SCAN A, B Assy or 50 (43) Y DRIVE Assy	Disconnection of cable detected	CN2101, CN2102, CN2301		
		IC5V UVP	SCAN IC, IC5V DC/DC Y SUS BLOCK	SCAN IC, Q2401, Q2402, IC2304,	
5 Y-DRIVE	50 (43) Y DRIVE Assy	IC5V OVP	IC5V DC/DC	IC2403, IC2411	
		+16.5V OCP	Y SUS BLOCK	IC2303, IC2307 (mask module), IC2301, IC2304, IC2305, R2332	
6 Y-DCDC	50 (43) Y DRIVE Assy	VOFS UVP	VOFS DC/DC	IC2404, IC2412, Q2404, Q2407, Q2312	
		VOFS OVP	VOFS DC/DC	IC2404, IC2412	
7 Y-SUS	50 (43) Y DRIVE Assy	Power-down caused by detection of middle-point voltage	Y RESONANCE BLOCK	Q2202, Q2203, Q2214, Q2205, Q2206, Q2208, Q2209, Q2212, IC2201, IC2202, D2201, D2206, D2220, D2211, D2225, D2230, Control signal series resistors	
		Disconnection of cable detected	CN1501		
8 ADPS	50 (43) ADDRESS	Power-down caused by detection of a power surge	ADR RESONANCE BLOCK	R1631, Q1601, D1602	
		Disconnection of cable detected	CN1001, CN1201		
9 X-DRIVE	50 (43) X DRIVE Assy	+16.5V OCP	X SUS BLOCK	IC1203, IC1207 (mask module), IC1204, IC1206, R1230, IC1205	
		VRN OCP	X SUS BLOCK	Q1205, R1226, R1251	
10 X-DCDC	50 (43) X DRIVE Assy	VRN OVP	VRN DC/DC	IC1403, IC1404	
		VRN UVP	VRN DC/DC	IC1402, IC1403, IC1404	
		Power-down caused by detection of middle-point voltage	X RESONANCE BLOCK	Q1205, R1226, R1251	
11 X-SUS	50 (43) X DRIVE Assy	Power-down caused by detection of middle-point voltage	X RESONANCE BLOCK	Q1102, Q1103, Q1114, Q1105, Q1108, Q1109, Q1111, Q1112, IC1101, IC1102, D1103, D1113, D1118, D1125, D1129, D1130, Control signal series resistors	
		DCDC +3.3V, +1.5V OVP	DC DC CONVERTER BLOCK	U5602 (DC DC CONVERTER Module)	
12 DIG-DCDC	DIGITAL VIDEO Assy	IC4 Drive STOP	IC4 BLOCK	IC5401	
15 IC4	DIGITAL VIDEO Assy				

OVP: Over Voltage Protection UVP: Under Voltage Protection OCP: Over Current Protection

7.1.3 PROCESSING AT THE TIME OF ABNORMALITIES

Fan and temperature sensor

● Circuitry

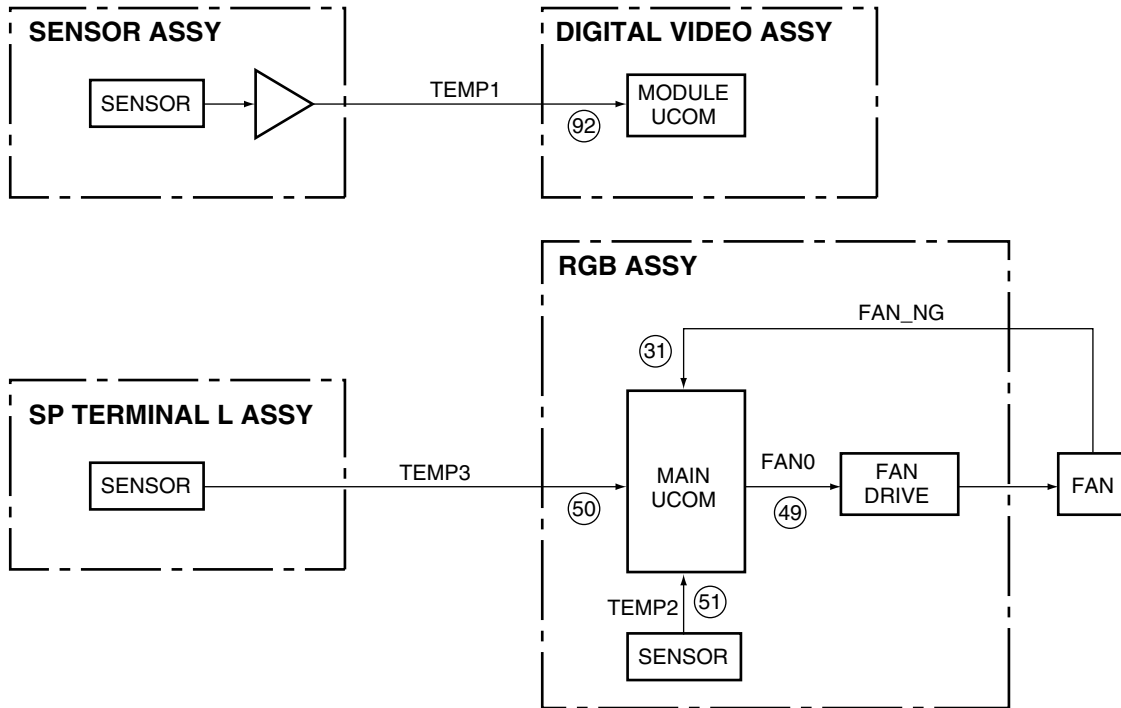

● Port monitoring specifications

Port Name	Shutdown Name	Assign	Control Microcomputer	Active	Remarks
FAN_NG	FAN	31	Main	Shutdown when the signal becomes high	Disconnection of the fan connector or abnormality in operation of the fan detected
TEMP1	Unit under high temperature	92	Module	Shutdown when the set value is exceeded	Monitoring high temperature of the panel, Drive system temperature compensation
TEMP2	Unit under high temperature	51	Main		Monitoring high temperature of boards
TEMP3	Unit under high temperature	50	Main		Monitoring ambient temperature

7.1.4 TEMPERATURE COMPENSATION OF DRIVE SYSTEM VOLTAGE

Function: To control the DRIVE-system voltage according to the temperature (Temperature compensation functions such that the voltage is lowered on the lower-temperature side and the voltage becomes higher on the higher-temperature side.)

Purpose: For improving the yield by compensating for the temperature characteristics of the panel

- Note:**
- Temperature compensation is performed only for the VSUS voltage, and not for the VOFS voltage. This compensation is controlled by the software.
 - Temperature compensation is carried out with the value of TEMP1.

7.1.5 POWER ON/OFF FUNCTION FOR THE LARGE-SIGNAL SYSTEM

Function: Only the power for the low voltage lines (16 V, 12 V, and 6.5 V) is on, and the power for the high voltage lines (VSUS, VADR) is off.

Usage: 1. Use when only an operational check for the low voltage lines is required, such as when making repairs.
2. Use when rewriting of a program for each microcomputer is required.

Methods: 1. Set the slide switch (S5201) on the DIGITAL VIDEO Assy to its upper position ("DRF" is mentioned on the board see Fig. below).
2. Send the "DRF" RS232C command to turn the large-signal system off.
3. Send the "DRN" RS232C command to turn the large-signal system on.

Notes:

- As the unit enters Power-Down and Muting On mode when Methods 1 and 2 are performed, and power-downs other than those caused by the power (PS_PD) and DC-DC-converter (DIGITAL_DC-DC) circuits are not activated.
- If the slide switch is set from OFF to ON while the power is on, a power-down will occur. Be sure to turn the power off before switching the slide switch.
- Although the "DRF" RS232C command is enabled during Standby, if the power is turned on then turned off, the unit will return to "DRN" mode.

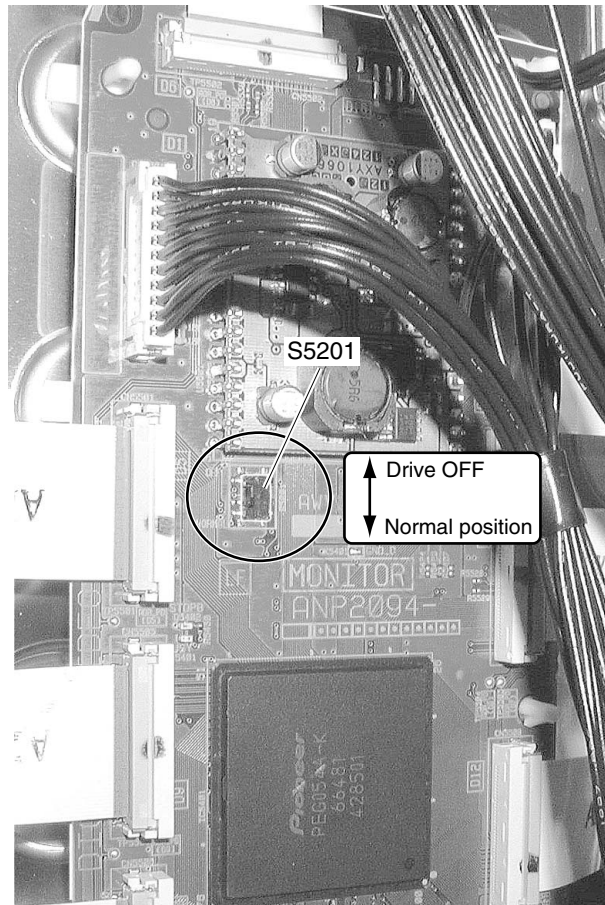

Fig. Drive OFF switch

Outline

The data on the adjustment values for the main unit are stored in an EEPROM (IC5206, 4 kbits) on the DIGITAL VIDEO Assy. Part of the data (area A in the figure below) are automatically copied to an EEPROM (IC7102, 2 kbits) mounted on the RGB Assy for backup. When the DIGITAL VIDEO Assy is replaced, the backup data on the adjustment values for the main unit stored in the RGB Assy can be copied to the new DIGITAL VIDEO Assy, thus enabling you to omit newly performing adjustments on the main unit. The logs for the product (power-down log, etc.) can also be copied.

Data to be backed up in the digital EEPROM (area A)

- Margin adjustment values (V_{sus}, V_{ofset})
- Power upper-limit adjustment value (ABL)
- PANEL white-balance adjustment values (PANEL-R HIGH, PANEL-G HIGH, PANEL-B HIGH, PANEL-R LOW, PANEL-G LOW, PANEL-B LOW)
- Drive waveform adjustment values (X-SUS-U1, X-SUS-U2, X-SUS-D1, X-SUS-D2, Y-SUS-U1, Y-SUS-U2, Y-SUS-D1, Y-SUS-D2, Y-SUS-D3, Y-SUS-D4)
- Hour meter
- Pulse meter
- Number of times the power has been turned on
- PD/SD logs

Basic flow of automatic backup

Using a keyword, the data in areas A and B are judged as to whether they have been adjusted or not, then copying is performed.

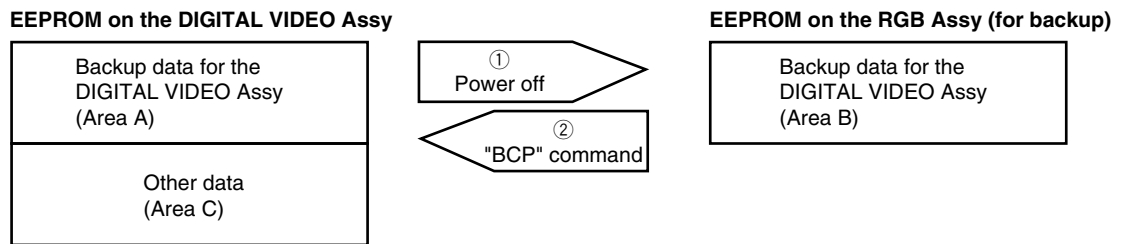

- ① The keyword on the DIGITAL VIDEO Assy is checked when the power is turned off, and if it is "adjusted", automatic backup is performed.
- ② If the keyword on the RGB Assy (Area B) is "adjusted," copying can be performed with the "BCP" RS232C command.

Actual automatic backup operations

1. When the DIGITAL VIDEO Assy is replaced with an Assy for service

Changing of keywords is not required. Replace the DIGITAL VIDEO Assy with an Assy for service, and send the "BCP" RS232C command. Thus, the backup data in the EEPROM on the RGB Assy are copied to the EEPROM on the DIGITAL VIDEO Assy for service.

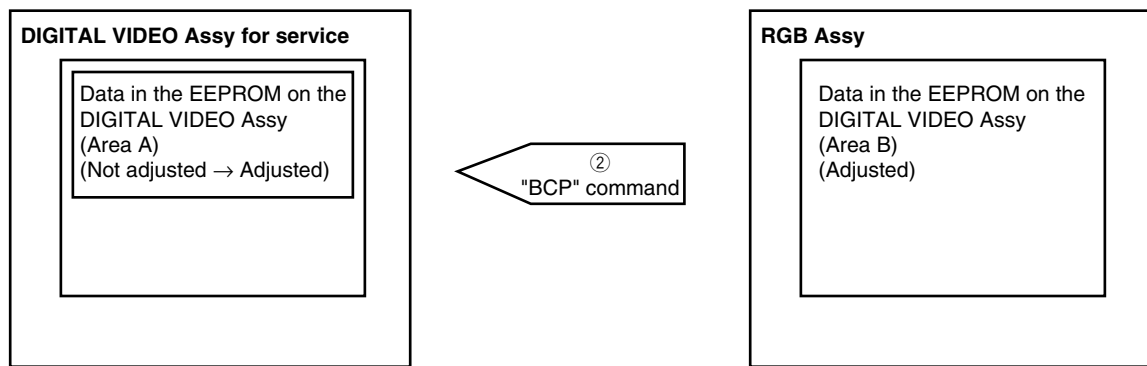

2. When a repaired DIGITAL VIDEO Assy is mounted on another unit (reuse of the repaired DIGITAL VIDEO Assy)

The keyword of the DIGITAL VIDEO Assy to be reused must be changed to "not adjusted" using the "UAJ" RS232C command.

Note 1: If a repaired DIGITAL VIDEO Assy is mounted in another unit (Unit 2) without this change of keyword, and the power to the unit 2 is turned off, the data in force before the repair of the DIGITAL VIDEO Assy will be copied to Area B of the RGB Assy of Unit 2, overwriting the data necessary for Unit 2. Once overwritten, the original data will not be restored.

3. When a repaired DIGITAL VIDEO Assy is mounted on the original unit (reuse of the repaired DIGITAL VIDEO Assy) Changing of keywords is not required. After the repaired DIGITAL VIDEO Assy is mounted in the original unit, the unit can operate with its latest adjustment values.

4. When both the DIGITAL VIDEO Assy and RGB Assy are simultaneously replaced with other assemblies The automatic backup function of this unit will not work properly.

Note 2: Readjustment of the main unit is required.

Note 3: After readjustment of the main unit, send the "FAJ" RS232C command to change the keyword of the DIGITAL VIDEO Assy to "adjusted." Thus, when the unit is turned off, automatic backup of adjustment data is performed properly.

Note 4: If readjustment of the main unit is totally impossible, it can be omitted by installing the EEPROM (IC5206, 4 kbits) originally mounted on the DIGITAL VIDEO Assy for service.

Note 5: After copying the backup data, turn the power off then back on to reflect the copied backup data.

B ■ Miscellaneous

If the white balance (W/B) value is largely shifted because of aging, etc., W/B adjustment is required. (As this may be a rare case, the adjustment procedures are described below, just for your reference.)

[W/B-adjustment procedures]

The W/B adjustment can be performed with the RS232C commands. Minolta CA-100 color difference meter are required.

- ① Send the "FAY" RS232C command to enter Factory mode.
- ② Set the keyword for the DIGITAL VIDEO Assy to "not adjusted" with the "UAJ" RS232C command.
- ③ Obtain the current adjustment values in the two adjustment tables (see "6.6 Command Description").
 - Shifting to Table 1: Send the "M51" and "F60" commands. Obtaining the adjustment values: Send the "GPW" command.
 - Shifting to Table 2: Send the "M51" and "F75" commands. Obtaining the adjustment values: Send the "GPW" command.
- ④ For each table, set the brightness.
 - Adjustment in Table 1: After sending the "F60" command, perform adjustment.
 - Adjustment in Table 2: After sending the "F75" command, perform adjustment.

For each table, change the RGB parameters so that the values measured using a Minolta color difference meter (CA-100) become as indicated below. In this case, any one of PRH, PGH, or PBH must be set to 256.

	Cd/mm	
x	285	"PRH****" : 000 - 511
y	289	"PGH****" : 000 - 511
		"PBH****" : 000 - 511

- ⑤ Check after adjustment
 - Shifting to Table 1: Send the "F60" command. Obtaining the adjustment values: Send the "GPW" command.
 - Shifting to Table 2: Send the "F75" command. Obtaining the adjustment values: Send the "GPW" command.

Check that the adjustment data have been changed.
- ⑥ Change the keyword for the DIGITAL VIDEO Assy to "adjusted" by sending the "FAJ" RS232C command.

Note: Use a Minolta CA-100 color difference meter or the equivalent for measurement. Otherwise, the specifications of the product cannot be assured.
- ⑦ Send the "FAN" RS232C command to enter Normal mode.
 - If the value is different from that you set, readjust it.

Note: To reset the adjustment to its original value, send the "BCP" RS232C command then turn the power off then back on to retrieve the backup data.

 - The setting values for color temperature differ between Factory mode and Normal mode. Therefore, the setting value for color-difference signals in Normal mode are different from those in Factory mode, even after the White Balance adjustment has been performed.

7.1.7 TROUBLESHOOTING

Video

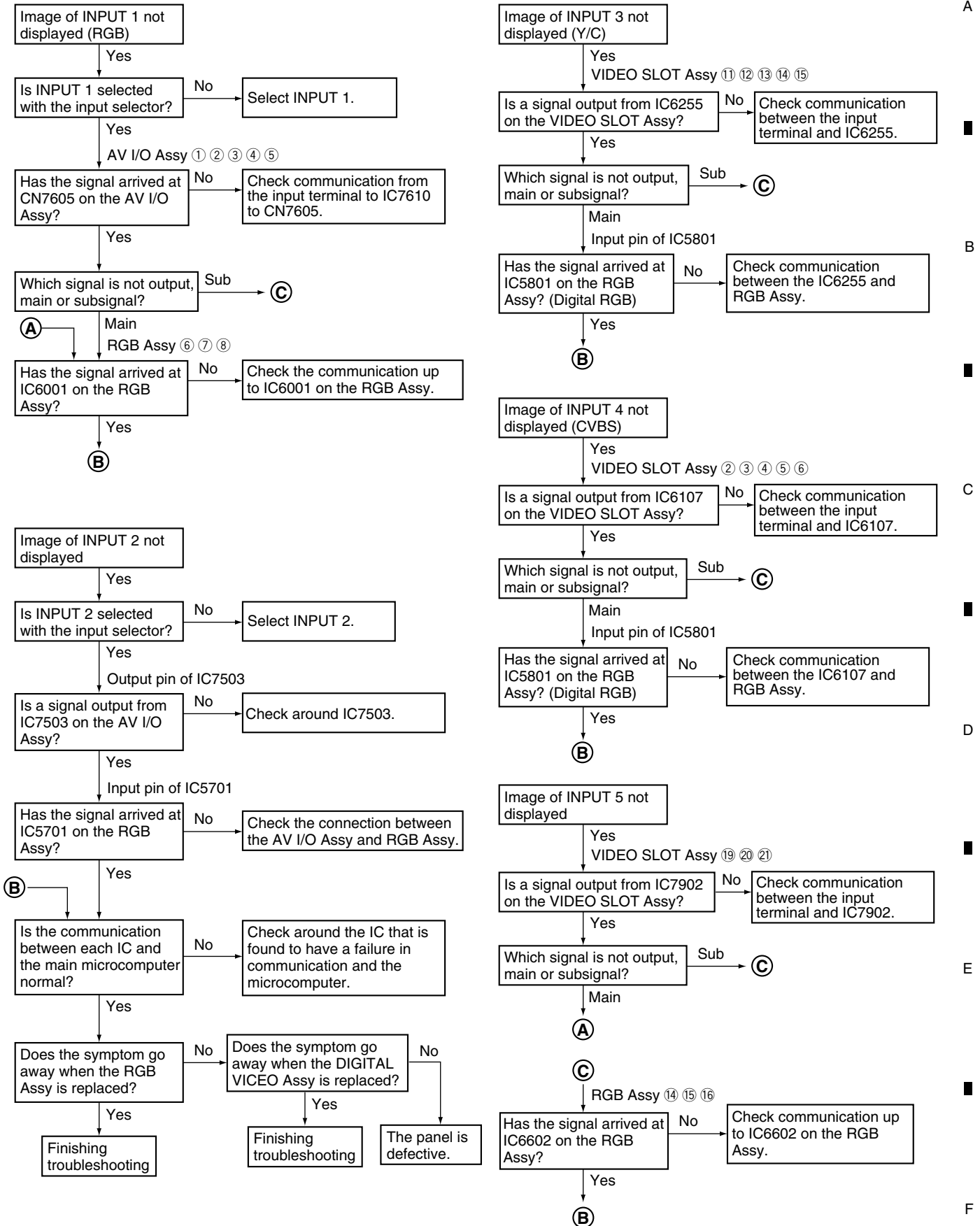

Audio

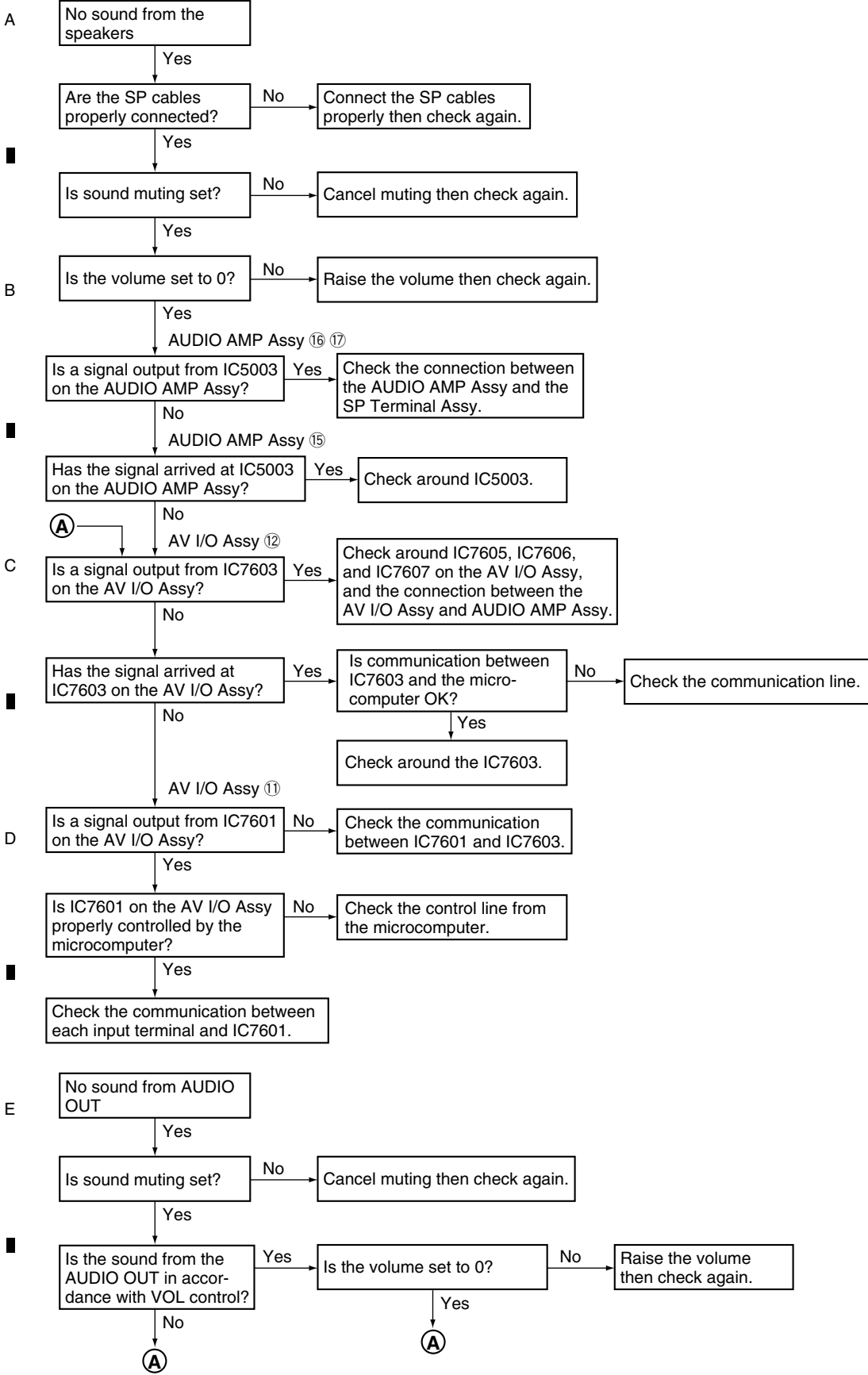

7.1.8 DISASSEMBLY

• PDP-504CMX model

1 Rear Case, Front Case

① Remove the grip by removing the four screws.

Note:

When reattaching the grip, be sure to securely tighten the screws.

② Remove the six screws.

③ Remove the seventeen screws.

Note :

When reattaching the rear case, first attach the screws for the holes indicated with *1 to place the rear case in the correct position.

④ Remove the rear case.

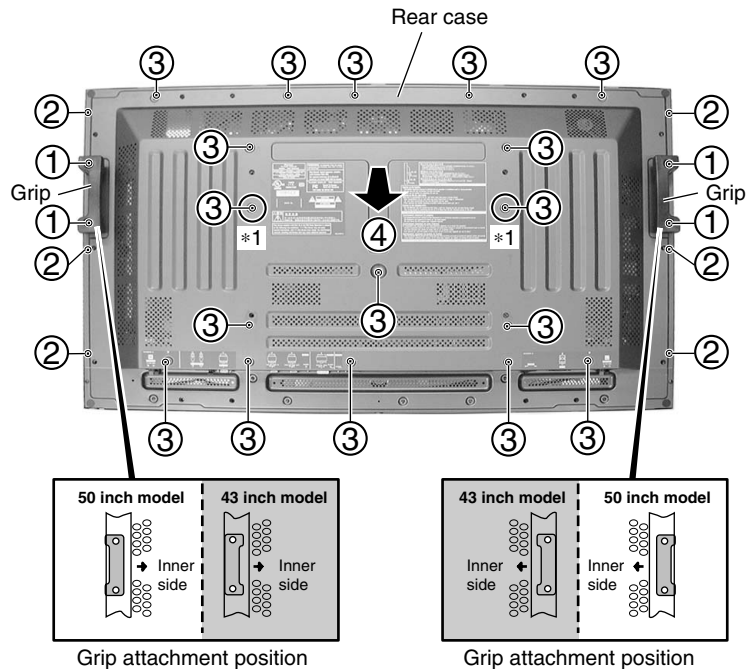

⑤ Remove the three screws.

⑥ Remove the one rivet.

⑦ Remove the lead cover.

⑧ Disconnect the flexible cable.

⑨ Remove the front case.

Note:

If only the front case must be removed, without removing the rear case, perform the steps ⑤ to ⑨.

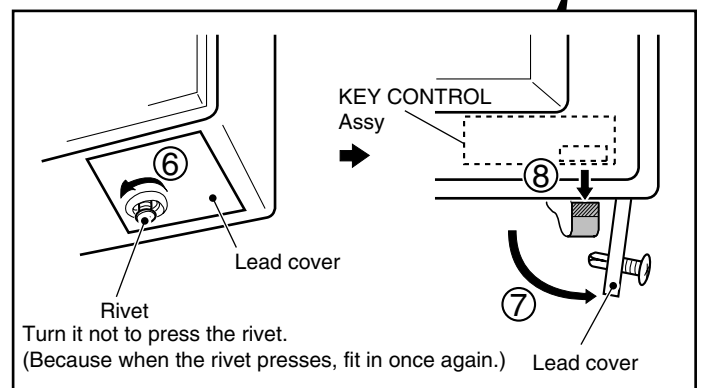
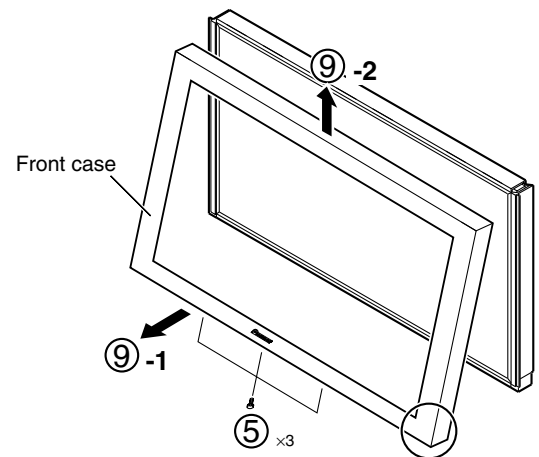

2 Multi Base Section

● Diagnosis of AV I/O Assy

- ① Remove the three nuts.
- ② Remove the six hexagon head screws.
- ③ Remove the one screw.
- ④ Remove the one pin grommet.
- ⑤ Remove the AV I/O Assy with the AV I/O I/F Assy.

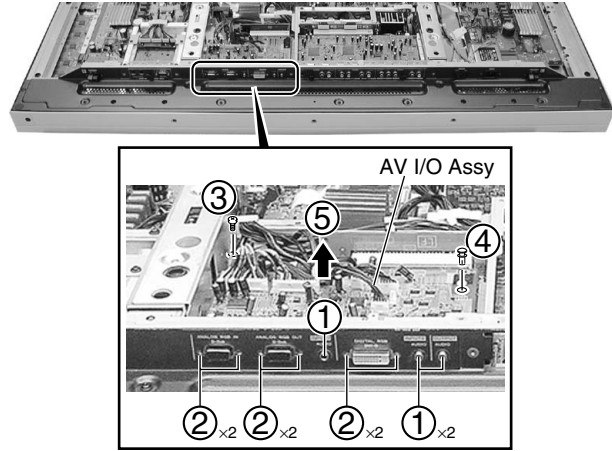

- ⑥ Remove the AV I/O Assy from the AV I/O I/F Assy.
- ⑦ Connect the AV I/O Assy to slot of the RGB Assy.

Diagnosis

Note:

- The cooling fan may rotate during diagnosis, in the following cases:
- When the rotation speed of the fan has been set to maximum for Integrator mode
 - When the ambient temperature surrounding the temperature sensor is about 35°C or higher

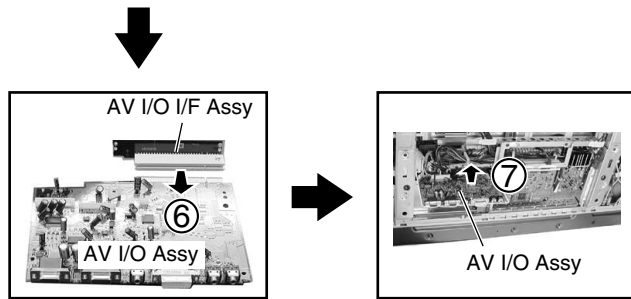

● Removing Multi Base Section

- ① Remove the one screw and two Torque screws.
- ② Remove the COMM SLOT Assy.
- ③ Remove the two Torque screws.
- ④ Remove the video card (option).
- ⑤ Remove the seven screws.
- ⑥ Remove the two screws.
- ⑦ Disconnect the some connectors at need.
- ⑧ Remove the terminal panel.
- ⑨ Remove the two screws.
- ⑩ Disconnect the some connectors at need.
- ⑪ Remove the multi base section.

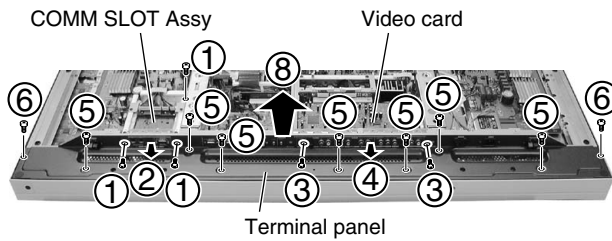

Note:

- Some tiny metal shavings may be released from the paring screw section when the VIDEO SLOT I/F Assy is detached from the sheet metal and is reattached to it. Be sure to clear away any shavings or other foreign matter before reattaching it to the RGB Assy.

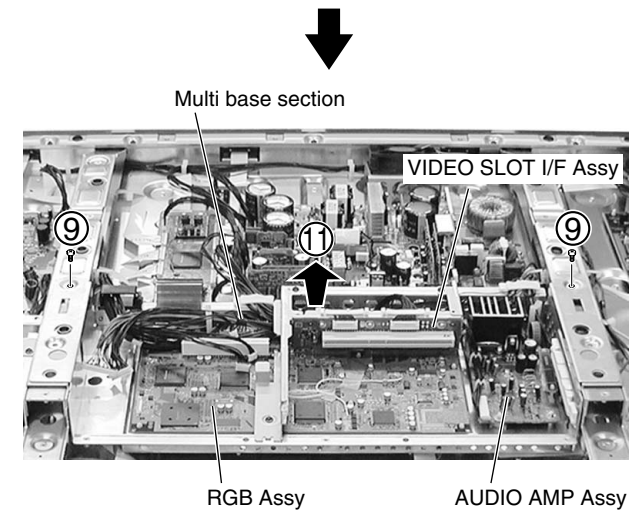

3 X CONNECTOR A Assy, B Assy, 50 SCAN A Assy and B Assy

● X CONNECTOR A and B Assy

- ① Remove the enclosure sheet 1.

Note:

Enclosure sheet 1 is attached to comply with the safety standards. Make sure that it will not be shifted or peeled off. If it is peeled off, securely reattach it in its original place.

- ② Remove the jumper wire by removing the flat clamp.
 ③ Remove the one nylon rivet.
 ④ Remove the one screw.

Note:

Be sure to remove this screw. If you don't, the connector on the LED OPT Assy may be damaged.

- ⑤ Remove the LED OPT Assy.
 ⑥ Remove the front chassis VR (50M) by removing the five screws.
 ⑦ Remove the seven screws.
 ⑧ Remove the two spacers.
 ⑨ Remove the X CONNECTOR A and B Assy.

Note when reassembling the front chassis VR (50M)

Remove or loosen the screws that secure the panel holder in order not to damage the front protect panel Assy.

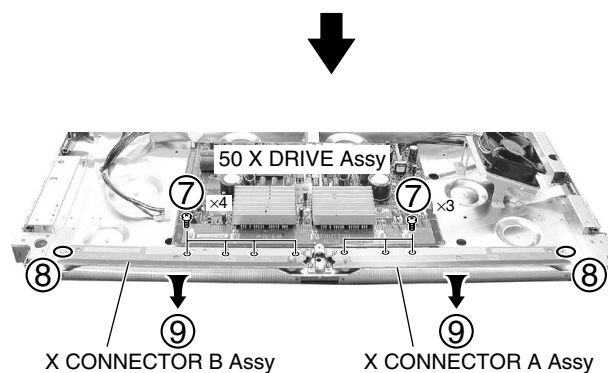
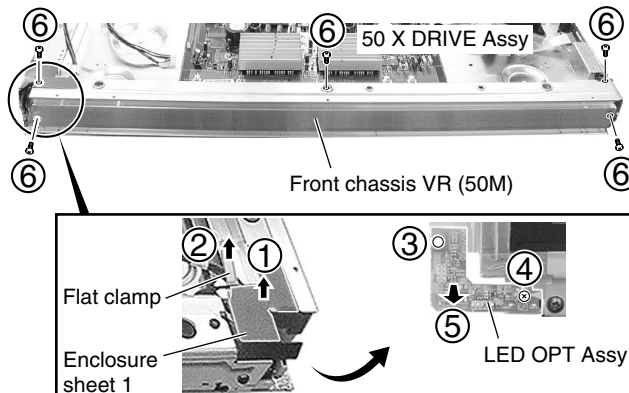

● 50 SCAN A and B Assy

- ① Remove the one nylon rivet.
 ② Remove the jumper wire by removing the flat clamp.
 ③ Remove the one screw.
 ④ Remove the front chassis VL (50M) by removing the five screws.
 ⑤ Remove the SCAN heatsink by removing the two screws.

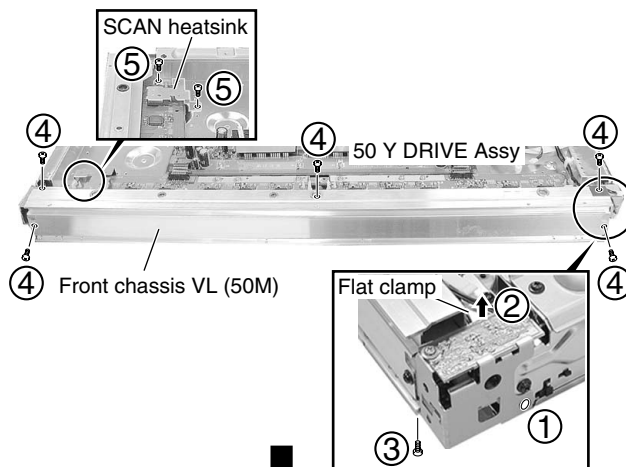

- ⑥ Remove the six screws.
 ⑦ Disconnect the two pin connectors.
 ⑧ Remove the six spacers.
 ⑨ Remove the 50 SCAN A and B Assy.

Note when reassembling the front chassis VL (50M)

Remove or loosen the screws that secure the panel holder in order not to damage the front protect panel Assy.

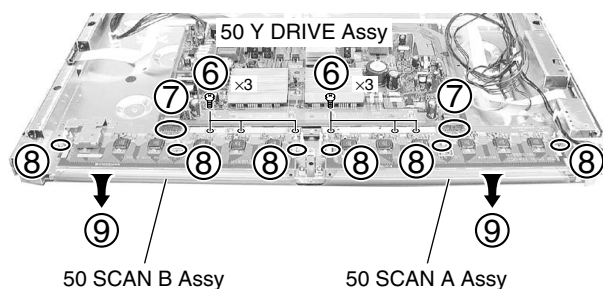

•PDP434cmx model

1 Rear Case, Front Case

① Remove the grip by removing the four screws.

Note:
When reattaching the grip, be sure to securely tighten the screws.

② Remove the six screws.

③ Remove the sixteen screws.

Note :
When reattaching the rear case, first attach the screws for the holes indicated with *1 to place the rear case in the correct position.

④ Remove the rear case.

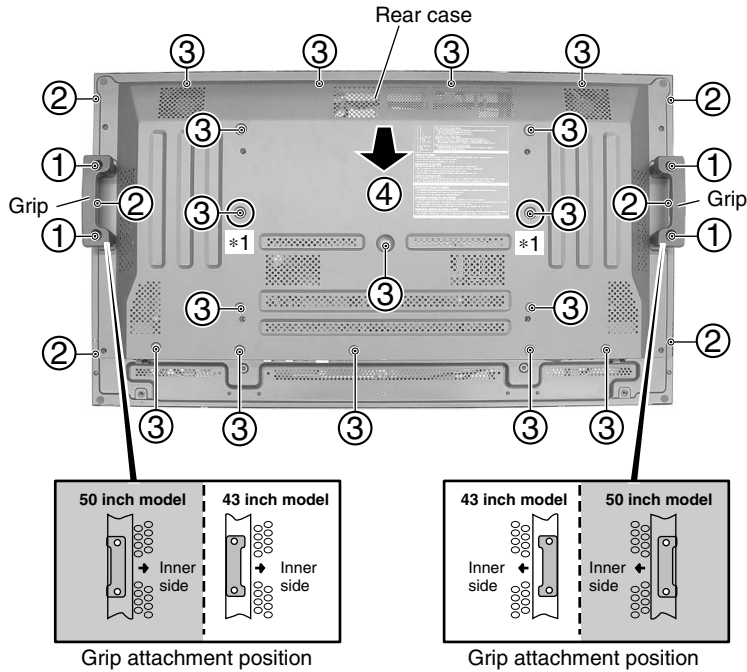

⑤ Remove the three screws.

⑥ Remove the one rivet.

⑦ Remove the lead cover.

⑧ Disconnect the flexible cable.

⑨ Remove the front case.

Note:
If only the front case must be removed, without removing the rear case, perform the steps ⑤ to ⑨.

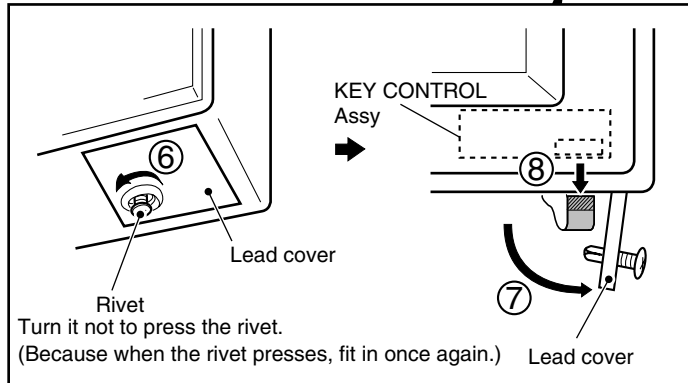
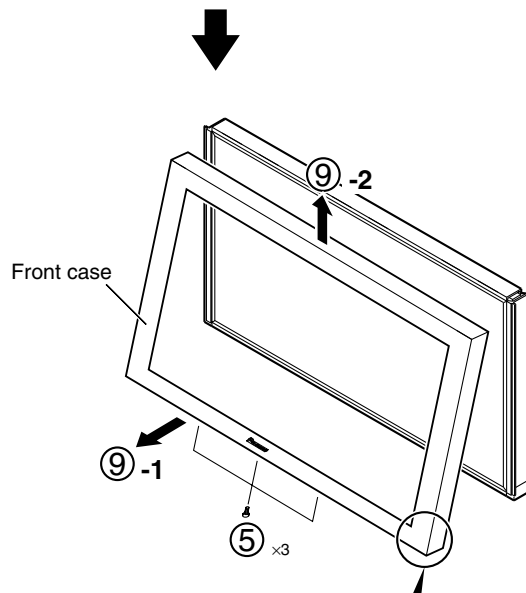

2 Multi Base Section

● Diagnosis of AV I/O Assy

- ① Remove the three nuts.
 - ② Remove the six hexagon head screws.
 - ③ Remove the one screw.
 - ④ Remove the one pin grommet.
 - ⑤ Remove the AV I/O Assy with the AV I/O I/F Assy.
-
- ⑥ Remove the AV I/O Assy from the AV I/O I/F Assy.
 - ⑦ Connect the AV I/O Assy to slot of the RGB Assy.

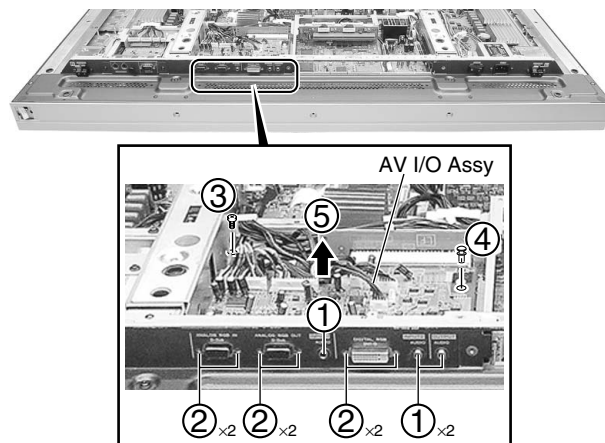

Diagnosis

Note:

- The cooling fan may rotate during diagnosis, in the following cases:
- When the rotation speed of the fan has been set to maximum for Integrator mode
 - When the ambient temperature surrounding the temperature sensor is about 35°C or higher

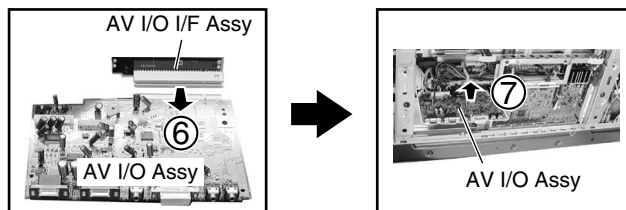

● Removing Multi Base Section

- ① Remove the one screw and two Torque screws.
 - ② Remove the COMM SLOT Assy.
 - ③ Remove the two Torque screws.
 - ④ Remove the video card (option).
 - ⑤ Remove the seven screws.
 - ⑥ Remove the two screws.
 - ⑦ Disconnect the some connectors at need.
 - ⑧ Remove the terminal panel.
-
- ⑨ Remove the two screws.
 - ⑩ Disconnect the some connectors at need.
 - ⑪ Remove the multi base section.

Note:

Some tiny metal shavings may be released from the paring screw section when the VIDEO SLOT I/F Assy is detached from the sheet metal and is reattached to it. Be sure to clear away any shavings or other foreign matter before reattaching it to the RGB Assy.

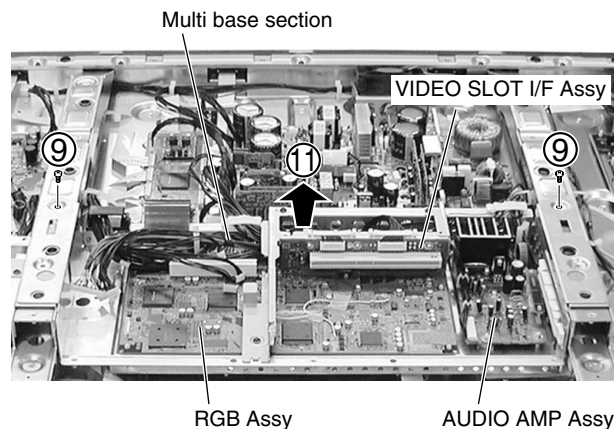
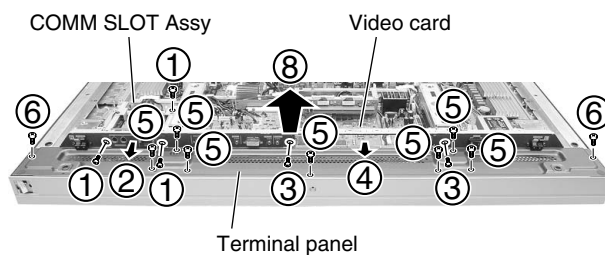

3 X CONNECTOR A, B Assy, 43 SCAN A, B Assy

● X CONNECTOR A and B Assy

- ① Remove the enclosure sheet 1.

Note:

Enclosure sheet 1 is attached to comply with the safety standards. Make sure that it will not be shifted or peeled off. If it is peeled off, securely reattach it in its original place.

- ② Remove the jumper wire by removing the flat clamp.
 ③ Remove the one nylon rivet.
 ④ Remove the one screw.

Note:

Be sure to remove this screw. If you don't, the connector on the LED OPT Assy may be damaged.

- ⑤ Remove the LED OPT Assy.
 ⑥ Remove the front chassis VR (43M) by removing the five screws.

- ⑦ Remove the seven screws.
 ⑧ Remove the two spacers.
 ⑨ Remove the X CONNECTOR A and B Assy.

Note when reassembling the front chassis VR (43M)

Remove or loosen the screws that secure the panel holder in order not to damage the front protect panel Assy.

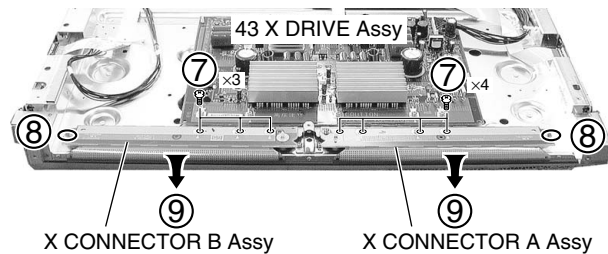
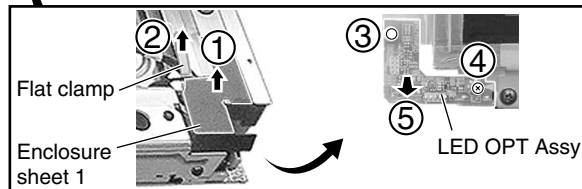
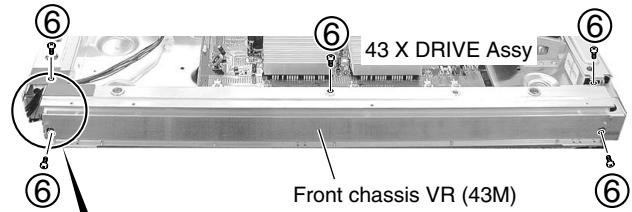

● 43 SCAN A and B Assy

- ① Remove the one nylon rivet.
 ② Remove the jumper wire by removing the flat clamp.
 ③ Remove the one screw.
 ④ Remove the front chassis VL (43M) by removing the five screws.

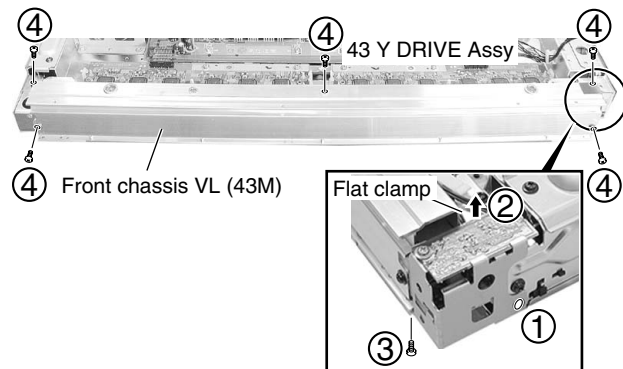

- ⑤ Remove the four screws.
 ⑥ Disconnect the two pin connectors.
 ⑦ Remove the six spacers.
 ⑧ Remove the 43 SCAN A and B Assy.

Note when reassembling the front chassis VL (43M)

Remove or loosen the screws that secure the panel holder in order not to damage the front protect panel Assy.

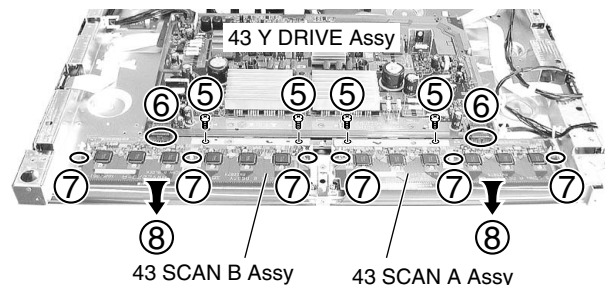

7.2 IC INFORMATION

The information shown in the list is basic information and may not correspond exactly to that shown in the schematic diagrams.

List of IC

BA10393F, BA10358F, STK795-512A, STK795-513A, STK795-510, STK795-511, AN16021AA-K, SN755866PZP, MBM29PL160BD-75PFTN, M30622F8PGP-K, PEG054A-K, AN5870SB, AD9883AKST-110, SM5301BS, BA7078AF, IC42S32200-7TG-K, MBM29PL3200BE70PFV, CXA3516AR, SII1161CTU-K, LA4625

BA10393F (50 X DRIVE ASSY : IC1103) , (43 X DRIVE ASSY : IC1103) (50 Y DRIVE ASSY : IC2211) , (43 Y DRIVE ASSY : IC2211)

• Comparator IC

Pin Arrangement (Top View) / Block Diagram

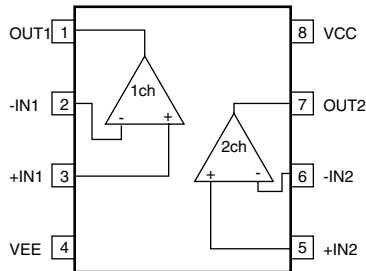

BA10358F (50 Y DRIVE ASSY : IC2406), (43 Y DRIVE ASSY : IC2406)

• Ope-Amp. IC

Pin Arrangement (Top View) / Block Diagram

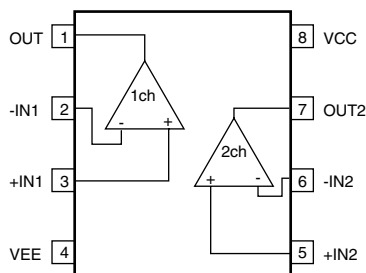

■ STK795-512A (50 X DRIVE ASSY: IC1203, IC1207)

PDP Mask Module IC

● Block Diagram

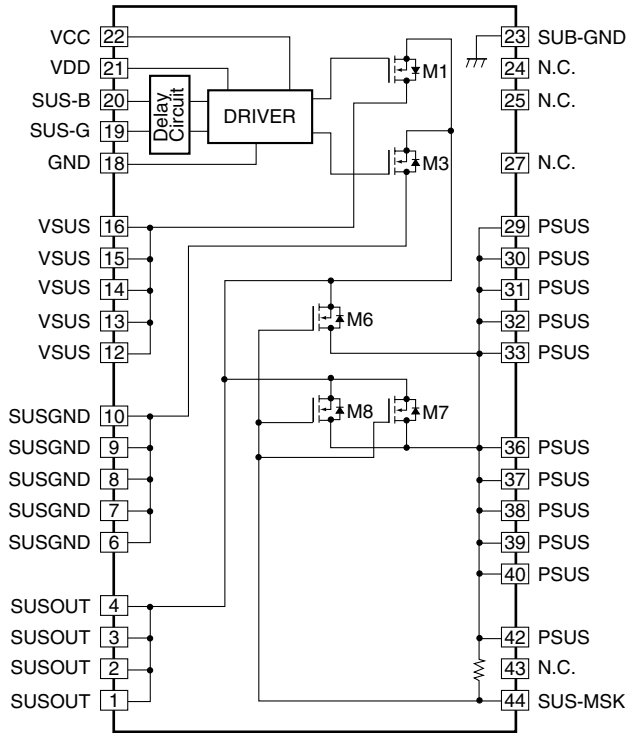

■ STK795-513A (50 Y DRIVE ASSY: IC2303, IC2307)

PDP Mask Module IC

● Block Diagram

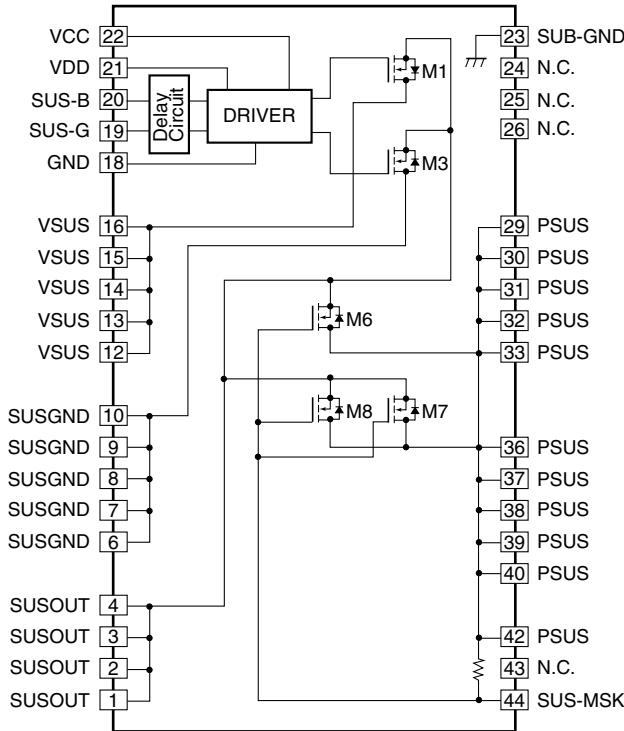

■ STK795-510 (43 X DRIVE ASSY: IC1203, IC1207)

• PDP Mask Module IC

● Block Diagram

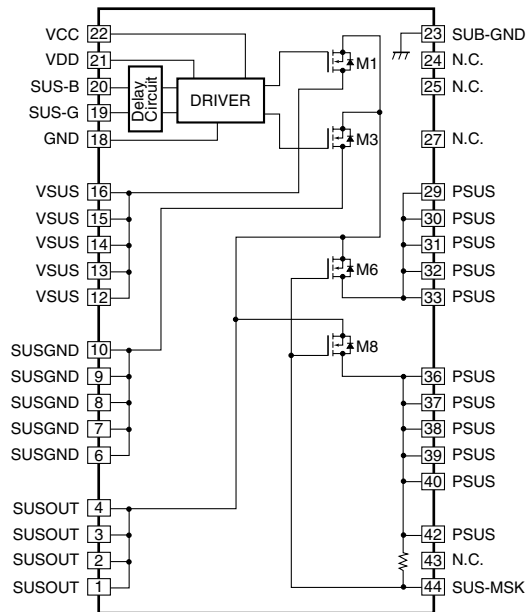

■ STK795-511 (43 Y DRIVE ASSY: IC2303, IC2307)

• PDP Mask Module IC

● Block Diagram

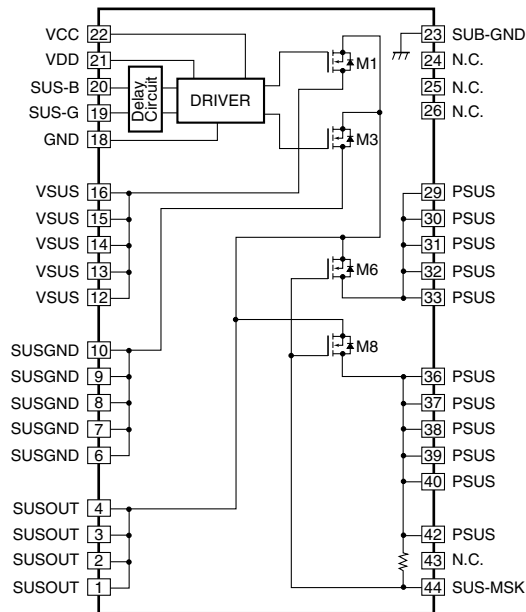

**AN16021AA-K (50 SCAN A ASSY : IC3001 - IC3006)
(50 SCAN B ASSY : IC3201 - IC3206)**

A • Mod Ucom

• Pin Arrangement (Top view)

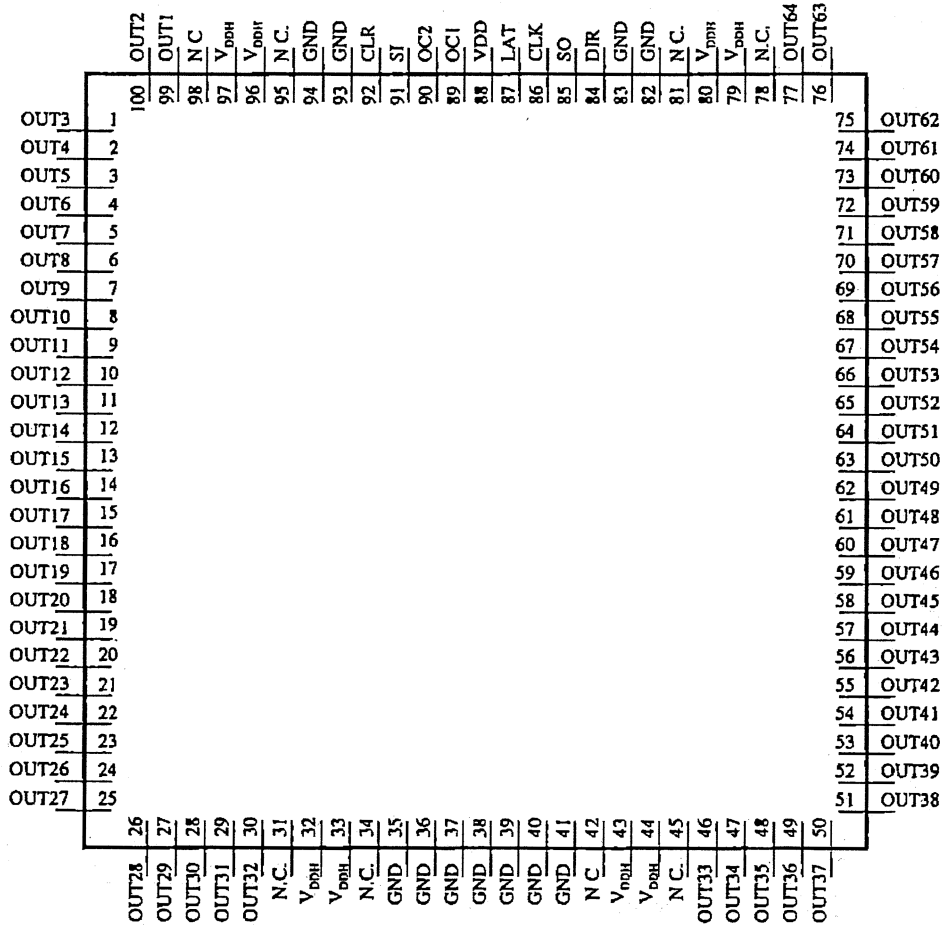

D

E

F

● Pin Function (1/2)

Pin No.	Pin Name	Type	Discription
1	OUT3	Output	High-voltage push-pull output pin
2	OUT4		
3	OUT5		
4	OUT6		
5	OUT7		
6	OUT8		
7	OUT9		
8	OUT10		
9	OUT11		
10	OUT12		
11	OUT13		
12	OUT14		
13	OUT15		
14	OUT16		
15	OUT17		
16	OUT18		
17	OUT19		
18	OUT20		
19	OUT21		
20	OUT22		
21	OUT23		
22	OUT24		
23	OUT25		
24	OUT26		
25	OUT27		
26	OUT28		
27	OUT29		
28	OUT30		
29	OUT31		
30	OUT32		
31	NC	-	Not connected
32	VDDH	Supply	High-voltage circuit supply pin
33	VDDH	Supply	High-voltage circuit supply pin
34	NC	-	Not connected
35	GND	Ground	GND pin
36	GND		
37	GND		
38	GND		
39	GND		
40	GND		
41	GND		
42	NC	-	Not connected
43	VDDH	Supply	High-voltage circuit supply pin
44	VDDH	Supply	High-voltage circuit supply pin
45	NC	-	Not connected
46	OUT33	Output	High-voltage push-pull output pin
47	OUT34		
48	OUT35		
49	OUT36		
50	OUT37		
51	OUT38		
52	OUT39		
53	OUT40		
54	OUT41		
55	OUT42		
56	OUT43		
57	OUT44		
58	OUT45		

● Pin Function (2/2)

Pin No.	Pin Name	Type	Discription															
59	OUT46	Output	High-voltage push-pull output pin															
60	OUT47																	
61	OUT48																	
62	OUT49																	
63	OUT50																	
64	OUT51																	
65	OUT52																	
66	OUT53																	
67	OUT54																	
68	OUT55																	
69	OUT56																	
70	OUT57																	
71	OUT58																	
72	OUT59																	
73	OUT60																	
74	OUT61																	
75	OUT62																	
76	OUT63																	
77	OUT64																	
78	NC	-	Not connected															
79	DDDH	Supply	High-voltage circuit supply pin															
80	DDDH	Supply	High-voltage circuit supply pin															
81	NC	-	Not connected															
82	GND	Ground	GND pin															
83	GND	Ground	GND pin															
84	DIR	Input	Setup pin of sift register sift direction L: Shift into reverse (SO → SI) H: Shift forward (SI → SO)															
85	SO	Input	Serial data input/output pin															
86	CLK	Input	Serial clock input pin Fetch SI or SO data to sift register by CLK rise edge															
87	LAT	Input	LAT data input pin L: Transfer shft register data to output latch H: Hold data to output latch															
88	VDD	Supply	Logic supply pin															
89	OC1	Input	Output control pin Control output according to the right truth value table															
90	OC2																	
			<table border="1"> <thead> <tr> <th>OC1</th> <th>OC2</th> <th>OUT</th> </tr> </thead> <tbody> <tr> <td>L</td> <td>L</td> <td>ALL Hi-Z</td> </tr> <tr> <td>L</td> <td>H</td> <td>DATA</td> </tr> <tr> <td>H</td> <td>L</td> <td>ALL L</td> </tr> <tr> <td>H</td> <td>H</td> <td>ALL H</td> </tr> </tbody> </table>	OC1	OC2	OUT	L	L	ALL Hi-Z	L	H	DATA	H	L	ALL L	H	H	ALL H
OC1	OC2	OUT																
L	L	ALL Hi-Z																
L	H	DATA																
H	L	ALL L																
H	H	ALL H																
91	SI	SI	Input/OutputSerial data input/output pin															
92	CLR		All output reset pin CLR pin: L → Normal operation CLR pin: H → All output High															
93	GND	Ground	GND pin															
94	GND	Ground	GND pin															
95	NC	-	Not connected															
96	VDDH	Supply	High-voltage circuit supply pin															
97	VDDH	Supply	High-voltage circuit supply pin															
98	NC	-	Not connected															
99	OUT1	Output	High-voltage push-pull output pin															
100	OUT2	Output	High-voltage push-pull output pin															

■ **SN755866PZP (43 SCAN A ASSY : IC3001 - IC3006)**
(43 SCAN B ASSY : IC3201 - IC3206)

• Mod Ucom

● **Pin Arrangement (Top view)**

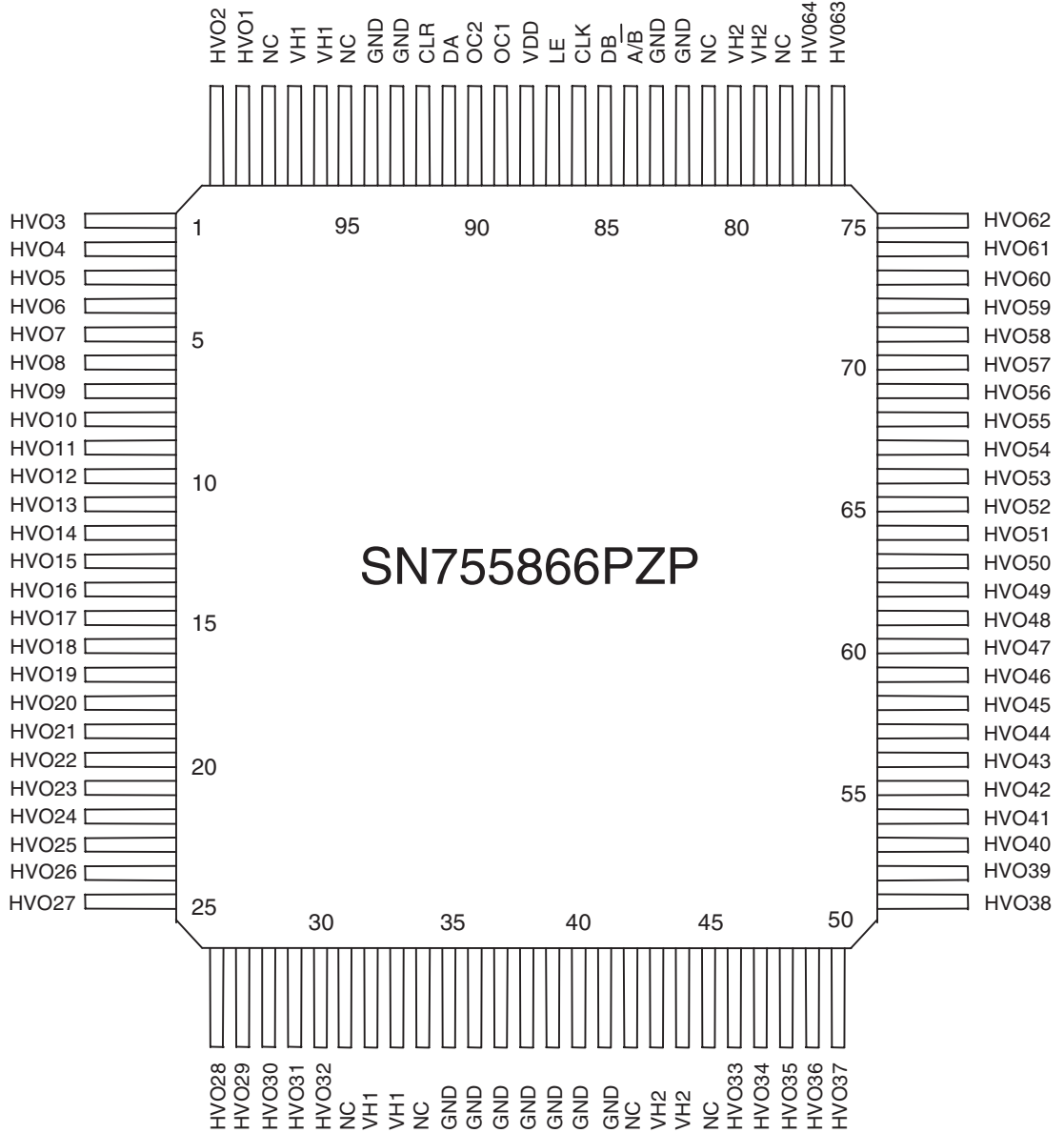

● Block Diagram

A
B
C
D
E
F

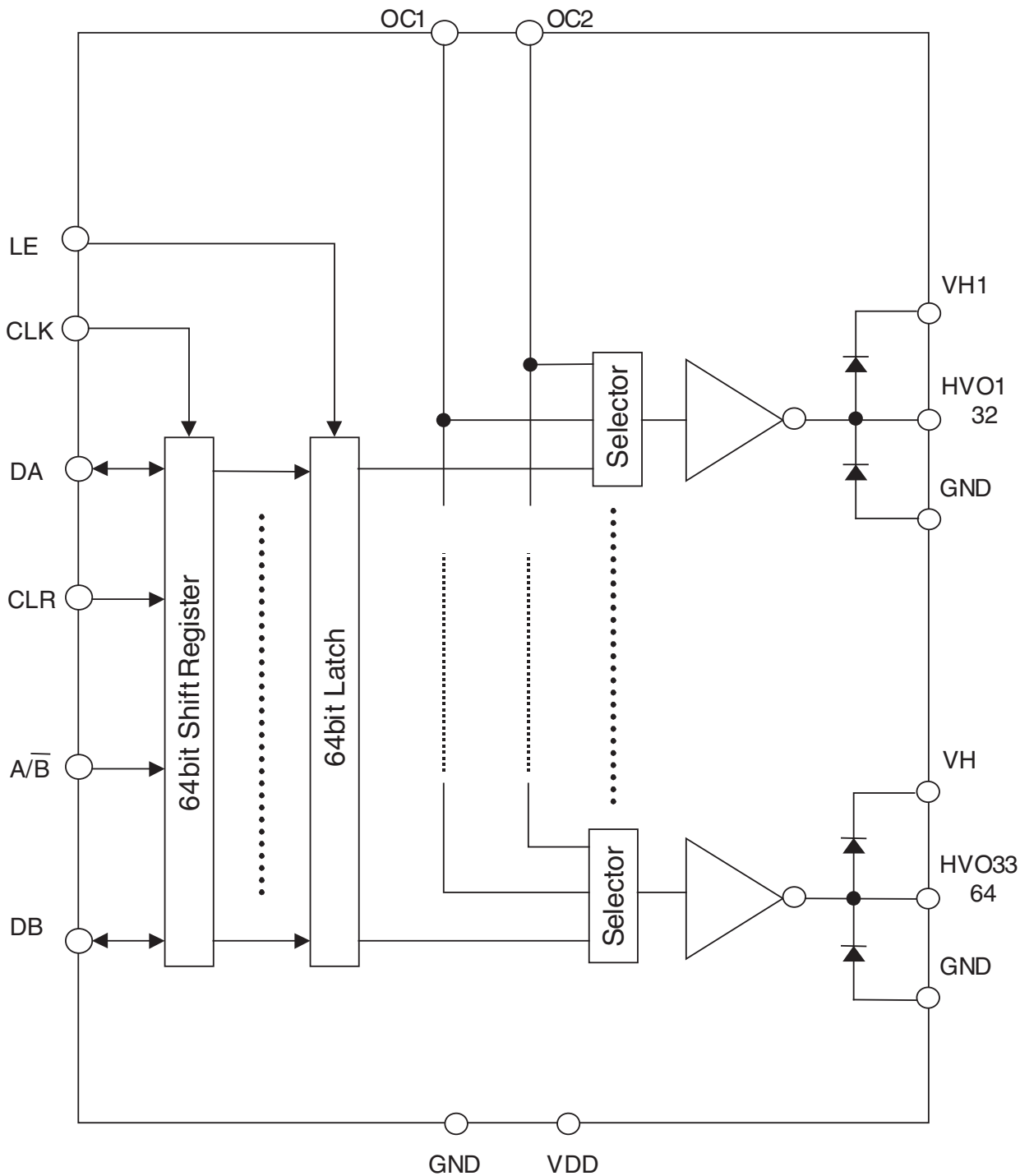

● Pin Function

Pin Name	No.	I/O	Function
CLK	86	I	Shift clock.
DA	91	I/O	Serial data input/output of Sift register pin.
DB	85	I/O	Serial data input/output of Sift register pin.
CLR	92	I	"H" level: sift register contents of "L" level.
LE	87	I	"L" level: Slew, "H" level: Larch
A/B	84	I	Setup pin of sift register sift direction.
OC1	89	I	HVO Output control pin.
OC2	90	I	HVO Output control pin.
HVO	99,100,1-30 46-77	O	High-voltage drive output. (HVO1 - HVO64)
VDD	88	-	Logic power supply.
GND	35-41,82-83 93-94	-	Reference potential 0V (HVO diode anode)
VH1	32,33,96,97	-	HVO1 - 32 High voltage circuit power supply (HVO diode cathode).
VH2	43,44,79,80	-	HVO33 - 64 High voltage circuit power supply (HVO diode cathode).
NC	31,34,41,45 78,81,95,98	-	NC pin

MBM29PL160BD-75PFTN (DIGITAL VIDEO ASSY : IC5305)

• Flash Memory IC

Block Diagram

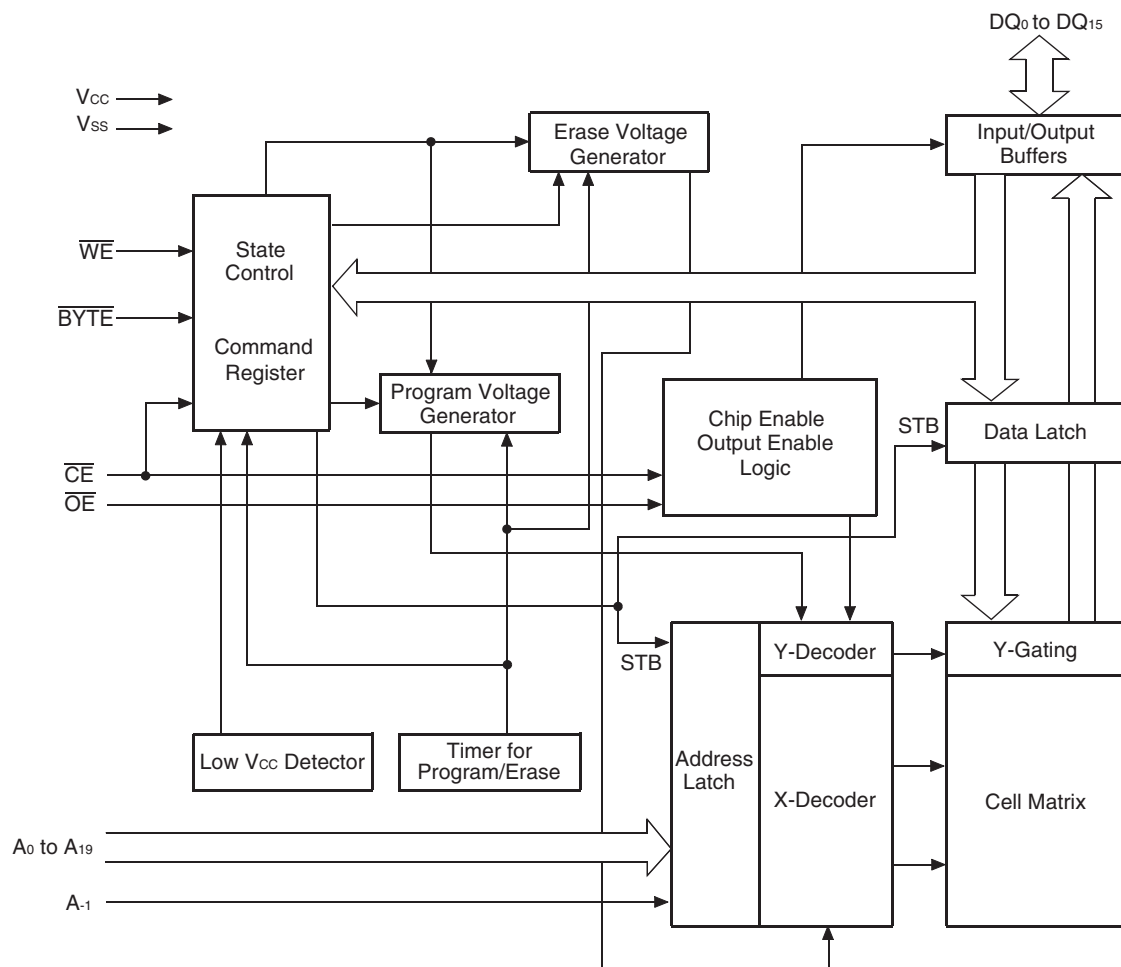

■ M30622F8PGP-K (DIGITAL VIDEO ASSY : IC5201)

• PDP UCOM

● Pin Function (1/2)

No.	Pin Name	Function	I/O	ACTIVE
1	VSUS	[D/A] Vofs power control	O	
2	VOFS	[D/A] Vofs power control	O	
3	TXD_IC4	3 serial communication with IC4MANTA - data transmission	O	
4	RXD_IC4	3 serial communication with IC4MANTA - data receive	I	
5	CLK_IC4	3 serial communication with IC4MANTA - clock output	O	
6	BYTE	(GND connection)	I	
7	CNVSS	Pin for processor mode setting (pull-down)	I	
8	NC	NC pin		
9	NC	NC pin		
10	RST_MD	Reset input	I	L
11	XOUT	Output for main clock	O	-
12	VSS	GND	-	-
13	XIN	Input for main clock	I	-
14	VCC1	Power supply = STB3.3V	-	-
15	NMI	(pull-up)	I	
16	REM_B	(Interruption) Remote control signal input (in the panel unit)	I	
17	KEY_B	(Interruption) Key signal input (in the panel unit)	I	
18	RST2	(Interruption) IC4 reset detection	I	L
19	HD_IN_B	HD signal existence distinction	I	L
20	PD_MUTE	Mute the power down output to the POWER SUPPLY Unit	O	L
21	PS_PD	PD signal in the POWER SUPPLY Unit	I	H
22	DCC_PD	PD signal of DC-DC converter	I	H
23	NC	NC pin		
24	NC	NC pin		
25	VD_IN	V. frequency count	I	L
26	EEPRST	EEPROM power SW	O	H
27	E_SCL	IIC clock output for EEPROM	O	
28	E_SDA	IIC data I/O for EEPROM	I/O	
29	TXD	Communication with flash ROM writer - data transmission	O	
30	RXD	Communication with flash ROM writer - data receive	I	
31	SCLK	Communication with flash ROM writer - clock input	I	
32	BUSY	Communication with flash ROM writer - busy output	O	
33	TXD0	UART communication with main UCOM (external PC) - data transmission	O	
34	RXD0	UART communication with main UCOM (external PC) - data receive	I	
35	NC	NC pin		
36	REQ_MD	Communication request to the main UCOM	O	H
37	PSW_D	Mute of DC-DC converter	O	H
38	WE_IC4	In IC4 (MANTA) rewriting, control for communication path switch	O	H
39	EPM	Setting pin for flash rewriting mode (pull-down)	I	
40	IC4_RST	IC4 forced reset	O	L
41	IC4_CE	Enable for IC4 communication	O	L
42	IC4_BUSY	Busy input for IC4 communication	I	H
43	REQ_IC4	Communication request from the IC4	I	H
44	CE	Setting pin for flash rewriting mode (pull-up)	I	
45	PSIZE	Panel size distinction	I	
46	B_SCL	IIC clock output for backup EEPROM	O	H
47	B_SDA	IIC DATA I/O for backup EEPROM	I/O	H
48	ADR_PD	PD signal of address junction	I	H
49	LED_G	Green LED control	O	L
50	LED_R	Red LED control	O	L

● Pin Function (2/2)

No.	Pin Name	Function	I/O	ACTIVE
51	DRV_OFF	Driving OFF	O	H
52	RELAY	Power ON control output	O	H
53	POWER	Power ON control input	I	H
54	MR_ST_B	MDR connection detection	I	L
55	OP_DET	Rear case open detection	I	
56	NC	NC pin		
57	PNL_MUTE	Panel mute	I	
58	DITHER	PC/VIDEO dither switch (panel module exclusive use)	I	
59	NC	NC pin		
60	VCC2	Power supply = STB 3.3V	-	-
61	PD_TRG	PD detection	I	L
62	VSS	GND	-	-
63	VH_PD	Vh power decrease PD	I	H
64	YDRV_PD	Y drive PD signal	I	H
65	YRES_PD	Y drive PD signal	I	H
66	YDCDC_PD	PD signal of Y drive DC-DC converter	I	H
67	IC5V_PD	5V power decrease PD	I	H
68	XSUS_PD	X drive PD signal	I	H
69	XDCDC_PD	PD signal of X drive DC-DC converter	I	H
70	XDRV_PD	X drive PD signal	I	H
71	NC	NC pin		
72	MR_AC	MR power monitor	I	H
73	AC_DET	AC power monitor at panel side (same signal as CST1)	I	L
74	DVI_MUTE	Mute of panel link output	O	H
75	A_MUTE	Audio mute	O	H
76	A_NG	Audio NG detection	I	L
77	A_SCL	IIC clock output for audio/others	O	L
78	A_SDA	IIC data I/O for audio/others	I/O	L
79	TRUBASS	TRUBASS ON/OFF	O	H
80	STB_SW	Standby setting of audio amp.	O	L
81	FOCUS	FOCUS ON/OFF	O	H
82	SRS	SRS ON/OFF	O	H
83	DDC_WP	DDCROM write protection	O	H
84	DVI_DET	DVI cable disconnection detection	I	H
85	RSTBTMDS	Reset detection of panel link receiver	I	L
86	L_SYNC	DE omission detection of the panel link	I	L
87	NC	NC pin		
88	NC	NC pin		
89	MASK1	[A/D] Mask display setting	I	
90	MAX_PLS2	[A/D] Brightness setting for panel module	I	
91	MAX_PLS1	[A/D] Brightness setting for panel module	I	
92	TEMP	[A/D] AD input for temperature sensor	I	
93	MODE	[A/D] Operation mode setting	I	
94	AVSS	GND for A/D input	-	-
95	MODEL	[A/D] CMX/HD/TV/WX distinction	I	
96	VREF	Reference voltage for A/D input	-	-
97	AVCC	Power supply for A/D input = STB3.3V	-	-
98	NC	NC pin		
99	NC	NC pin		
100	AMG_MD	Address emergency monitor	I	H

■ PEG054A-K (DIGITAL VIDEO ASSY : IC5401)

• PDP ASIC IC4

● Pin Function (1/10)

Ball No.	No.	Pin Name	Function
A1	1	BAI_6	A phase signal input of B video (sixth bit)
B1	2	BAI_5	A phase signal input of B video (fifth bit)
C1	3	BAI_4	A phase signal input of B video (fourth bit)
D1	4	NC	NC pin
E1	5	NC	NC pin
F1	6	BAI_3	A phase signal input of B video (fifth bit)
G1	7	BAI_2	A phase signal input of B video (fourth bit)
H1	8	FIELD	FIELD signal input
J1	9	XSUSB_12	X-Drive control signal output
K1	10	XSUSB_10	X-Drive control signal output
L1	11	XSUSB_4	X-Drive control signal output
M1	12	XSUSB_0	X-Drive control signal output
N1	13	XSUSA_10	X-Drive control signal output
P1	14	XSUSA_4	X-Drive control signal output
R1	15	XSUSA_2	X-Drive control signal output
T1	16	ADRS_0	Address control signal output
U1	17	AD6TXOUT3M	Address LVDS signal output
V1	18	AD6TXCLKOUTM	Address LVDS signal output
W1	19	AD6TXOUT2M	Address LVDS signal output
Y1	20	AD6TXOUT1M	Address LVDS signal output
AA1	21	AD6TXOUT0M	Address LVDS signal output
AB1	22	AD7TXOUT3M	Address LVDS signal output
AC1	23	AD7TXCLKOUTM	Address LVDS signal output
AD1	24	AD7TXOUT2M	Address LVDS signal output
AE1	25	AD7TXOUT1M	Address LVDS signal output
AF1	26	AD7TXOUT0M	Address LVDS signal output
AF2	27	AD7TXOUT0P	Address LVDS signal output
AF3	28	VSSLA	GND
AF4	29	AD3TXOUT3M	Address LVDS signal output
AF5	30	AD3TXCLKOUTM	Address LVDS signal output
AF6	31	AD3TXOUT2M	Address LVDS signal output
AF7	32	AD3TXOUT1M	Address LVDS signal output
AF8	33	AD3TXOUT0M	Address LVDS signal output
AF9	34	AD2TXOUT3M	Address LVDS signal output
AF10	35	AD2TXCLKOUTM	Address LVDS signal output
AF11	36	AD2TXOUT2M	Address LVDS signal output
AF12	37	AD2TXOUT1M	Address LVDS signal output
AF13	38	AD2TXOUT0M	Address LVDS signal output
AF14	39	AD1TXOUT3M	Address LVDS signal output
AF15	40	AD1TXCLKOUTM	Address LVDS signal output
AF16	41	AD1TXOUT2M	Address LVDS signal output
AF17	42	AD1TXOUT1M	Address LVDS signal output
AF18	43	AD1TXOUT0M	Address LVDS signal output
AF19	44	AD0TXOUT3M	Address LVDS signal output
AF20	45	AD0TXCLKOUTM	Address LVDS signal output
AF21	46	AD0TXOUT2M	Address LVDS signal output
AF22	47	AD0TXOUT1M	Address LVDS signal output
AF23	48	AD0TXOUT0M	Address LVDS signal output
AF24	49	VSSL15	GND
AF25	50	AD4TXOUT3P	Address LVDS signal output

● Pin Function (2/10)

Ball No.	No.	Pin Name	Function
AF26	51	AD4TXOUT3M	Address LVDS signal output
AE26	52	AD4TXCLKOUTM	Address LVDS signal output
AD26	53	AD4TXOUT2M	Address LVDS signal output
AC26	54	AD4TXOUT1M	Address LVDS signal output
AB26	55	AD4TXOUT0M	Address LVDS signal output
AA26	56	AD5TXOUT3M	Address LVDS signal output
Y26	57	AD5TXCLKOUTM	Address LVDS signal output
W26	58	AD5TXOUT2M	Address LVDS signal output
V26	59	AD5TXOUT1M	Address LVDS signal output
U26	60	AD5TXOUT0M	Address LVDS signal output
T26	61	SDIDBI_N	JTAG signal
R26	62	SDIJTAG	JTAG signal
P26	63	GPIO0_3	Microcomputer macro general-purpose port
N26	64	GPIO0_1	Microcomputer macro general-purpose port
M26	65	YSUSA_4	Y-Drive control signal output
L26	66	YSUSA_10	Y-Drive control signal output
K26	67	YSUSA_14	Y-Drive control signal output
J26	68	YSUSB_4	Y-Drive control signal output
H26	69	YSUSB_6	Y-Drive control signal output
G26	70	YSUSB_10	Y-Drive control signal output
F26	71	YSUSB_14	Y-Drive control signal output
E26	72	NC	NC pin
D26	73	NC	NC pin
C26	74	SCAN_10	Scan control signal output
B26	75	CSIOTXD	Communication with microcomputer
A26	76	CSRD_N	Communication with microcomputer
A25	77	CSCS_N0	Communication with microcomputer
A24	78	EXA16	Flash memory address bus
A23	79	EXA15	Flash memory address bus
A22	80	EXA14	Flash memory address bus
A21	81	EXA13	Flash memory address bus
A20	82	EXA12	Flash memory address bus
A19	83	EXA10	Flash memory address bus
A18	84	EXA7	Flash memory address bus
A17	85	EXA1	Flash memory address bus
A16	86	EXDIO_3	Flash memory data bus
A15	87	EXDIO_5	Flash memory data bus
A14	88	EXDIO_11	Flash memory data bus
A13	89	TRNSEND_O	NC pin
A12	90	RBI_5	B phase signal input of R video (fifth bit)
A11	91	RBI_0	B phase signal input of R video (0 bit)
A10	92	GBI_8	B phase signal input of G video (eighth bit)
A9	93	GBI_2	B phase signal input of G video (second bit)
A8	94	BBI_6	B phase signal input of B video (sixth bit)
A7	95	BBI_0	B phase signal input of B video (0 bit)
A6	96	VDI	VD signal input
A5	97	RAI_5	A phase signal input of R video (fifth bit)
A4	98	DCLKI	CLK input
A3	99	GAI_4	A phase signal input of G video (fourth bit)
A2	100	BAI_9	A phase signal input of B video (ninth bit)

● Pin Function (3/10)

Ball No.	No.	Pin Name	Function
B2	101	BAI_8	A phase signal input of B video (eighth bit)
C2	102	BAI_7	A phase signal input of B video (seventh bit)
D2	103	GND	GND
E2	104	NC	NC
F2	105	NC	NC
G2	106	BAI_1	A phase signal input of B video (first bit)
H2	107	XSUSB_15	X-Drive control signal output
J2	108	GND	GND
K2	109	XSUSB_9	X-Drive control signal output
L2	110	XSUSB_3	X-Drive control signal output
M2	111	XSUSA_15	X-Drive control signal output
N2	112	XSUSA_9	X-Drive control signal output
P2	113	GND	GND
R2	114	XSUSA_1	X-Drive control signal output
T2	115	TEST2	Test signal input (Not used)
U2	116	AD6TXOUT3P	Address LVDS signal output
V2	117	AD6TXCLKOUTP	Address LVDS signal output
W2	118	AD6TXOUT2P	Address LVDS signal output
Y2	119	AD6TXOUT1P	Address LVDS signal output
AA2	120	AD6TXOUT0P	Address LVDS signal output
AB2	121	AD7TXOUT3P	Address LVDS signal output
AC2	122	AD7TXCLKOUTP	Address LVDS signal output
AD2	123	AD7TXOUT2P	Address LVDS signal output
AE2	124	AD7TXOUT1P	Address LVDS signal output
AE3	125	VSSLA	GND
AE4	126	AD3TXOUT3P	Address LVDS signal output
AE5	127	AD3TXCLKOUTP	Address LVDS signal output
AE6	128	AD3TXOUT2P	Address LVDS signal output
AE7	129	AD3TXOUT1P	Address LVDS signal output
AE8	130	AD3TXOUT0P	Address LVDS signal output
AE9	131	AD2TXOUT3P	Address LVDS signal output
AE10	132	AD2TXCLKOUTP	Address LVDS signal output
AE11	133	AD2TXOUT2P	Address LVDS signal output
AE12	134	AD2TXOUT1P	Address LVDS signal output
AE13	135	AD2TXOUT0P	Address LVDS signal output
AE14	136	AD1TXOUT3P	Address LVDS signal output
AE15	137	AD1TXCLKOUTP	Address LVDS signal output
AE16	138	AD1TXOUT2P	Address LVDS signal output
AE17	139	AD1TXOUT1P	Address LVDS signal output
AE18	140	AD1TXOUT0P	Address LVDS signal output
AE19	141	AD0TXOUT3P	Address LVDS signal output
AE20	142	AD0TXCLKOUTP	Address LVDS signal output
AE21	143	AD0TXOUT2P	Address LVDS signal output
AE22	144	AD0TXOUT1P	Address LVDS signal output
AE23	145	AD0TXOUT0P	Address LVDS signal output
AE24	146	VSSL15	GND
AE25	147	AD4TXCLKOUTP	Address LVDS signal output
AD25	148	AD4TXOUT2P	Address LVDS signal output
AC25	149	AD4TXOUT1P	Address LVDS signal output
AB25	150	AD4TXOUT0P	Address LVDS signal output

● Pin Function (4/10)

Ball No.	No.	Pin Name	Function
AA25	151	AD5TXOUT3P	Address LVDS signal output
Y25	152	AD5TXCLKOUTP	Address LVDS signal output
W25	153	AD5TXOUT2P	Address LVDS signal output
V25	154	AD5TXOUT1P	Address LVDS signal output
U25	155	AD5TXOUT0P	Address LVDS signal output
T25	156	SDITRST_N	JTAG signal
R25	157	RESETX	Reset input
P25	158	GND	GND
N25	159	GPIO0_0	Microcomputer macro general-purpose port
M25	160	YSUSA_5	Y-Drive control signal output
L25	161	YSUSA_11	Y-Drive control signal output
K25	162	YSUSA_15	Y-Drive control signal output
J25	163	GND	GND
H25	164	YSUSB_7	Y-Drive control signal output
G25	165	YSUSB_11	Y-Drive control signal output
F25	166	NC	NC pin
E25	167	NC	NC pin
D25	168	GND	GND
C25	169	SCAN_11	Scan control signal output
B25	170	CSIORXD	Communication with UCOM
B24	171	CSIOSCKI	Communication with UCOM
B23	172	UARTTXD	Communication with UCOM
B22	173	UARTRXD	Communication with UCOM
B21	174	CSWR_N0	Communication with UCOM
B20	175	GND	GND
B19	176	EXA9	Flash memory address bus
B18	177	EXA6	Flash memory address bus
B17	178	EXA0	Flash memory address bus
B16	179	GND	GND
B15	180	EXDIO_6	Flash memory data bus
B14	181	EXDIO_12	Flash memory data bus
B13	182	RBI_9	B phase signal input of R video (ninth bit)
B12	183	RBI_4	B phase signal input of R video (fourth bit)
B11	184	GND	GND
B10	185	GBI_7	B phase signal input of G video (seventh bit)
B9	186	GBI_1	B phase signal input of G video (first bit)
B8	187	BBI_5	B phase signal input of B video (fifth bit)
B7	188	GND	GND
B6	189	HDI	HD signal input
B5	190	RAI_4	A phase signal input of R video (fourth bit)
B4	191	GAI_9	A phase signal input of G video (ninth bit)
B3	192	GAI_3	A phase signal input of G video (third bit)
C3	193	GAI_2	A phase signal input of G video (second bit)
D3	194	VDDD33	3.3V power supply
E3	195	GAI_1	A phase signal input of G video (first bit)
F3	196	GAI_0	A phase signal input of G video (0 bit)
G3	197	NC	NC pin
H3	198	XSUSB_14	X-Drive control signal output
J3	199	VDDIO	3.3V power supply
K3	200	XSUSB_8	X-Drive control signal output

● Pin Function (5/10)

Ball No.	No.	Pin Name	Function
L3	201	XSUSB_2	X-Drive control signal output
M3	202	XSUSA_14	X-Drive control signal output
N3	203	XSUSA_8	X-Drive control signal output
P3	204	VDDIO	3.3V power supply
R3	205	XSUSA_0	X-Drive control signal output
T3	206	TEST1	Test signal input (Not used)
U3	207	VSSLA	GND
V3	208	VSSLA	GND
W3	209	VSSLA	GND
Y3	210	VSSLA	GND
AA3	211	VSSLA	GND
AB3	212	VSSLA	GND
AC3	213	VSSLA	GND
AD3	214	VSSLA	GND
AD4	215	VSSLA	GND
AD5	216	VSSLA	GND
AD6	217	VSSLA	GND
AD7	218	VSSLA	GND
AD8	219	VSSLA	GND
AD9	220	VSSLA	GND
AD10	221	VSSLA	GND
AD11	222	VSSLA	GND
AD12	223	VSSLA	GND
AD13	224	VSSLA	GND
AD14	225	VSSLA	GND
AD15	226	VSSLA	GND
AD16	227	VSSLA	GND
AD17	228	VSSLA	GND
AD18	229	VSSLA	GND
AD19	230	VSSLA	GND
AD20	231	VSSLA	GND
AD21	232	VSSLA	GND
AD22	233	VSSLA	GND
AD23	234	VSSLA	GND
AD24	235	VSSLA	GND
AC24	236	VSSLA	GND
AB24	237	VSSLA	GND
AA24	238	VSSLA	GND
Y24	239	VSSLA	GND
W24	240	VSSLA	GND
V24	241	VSSLA	GND
U24	242	VSSLA	GND
T24	243	SDITDO	JTAG signal
R24	244	GPIO0_7	Microcomputer macro general-purpose port
P24	245	VDDIO	3.3V power supply
N24	246	YSUSA_0	Y-Drive control signal output
M24	247	YSUSA_6	Y-Drive control signal output
L24	248	YSUSA_12	Y-Drive control signal output
K24	249	YSUSB_0	Y-Drive control signal output
J24	250	VDDD33	3.3V power supply

● Pin Function (6/10)

Ball No.	No.	Pin Name	Function
H24	251	YSUSB_8	Y-Drive control signal output
G24	252	NC	NC pin
F24	253	YSUSB_15	Y-Drive control signal output
E24	254	SCAN_3	Scan control signal output
D24	255	VDDD33	3.3V power supply
C24	256	SCAN_12	Scan control signal output
C23	257	SCAN_13	Scan control signal output
C22	258	SCAN_14	Scan control signal output
C21	259	SCAN_15	Scan control signal output
C20	260	VDDIO	3.3V power supply
C19	261	EXA8	Flash memory address bus
C18	262	EXA5	Flash memory address bus
C17	263	CLKD	CLK input (60MHz)
C16	264	VDDIO	3.3V power supply
C15	265	EXDIO_7	Flash memory data bus
C14	266	EXDIO_13	Flash memory data bus
C13	267	RBI_8	B phase signal input of R video (eighth bit)
C12	268	RBI_3	B phase signal input of R video (third bit)
C11	269	VDDIO	3.3V power supply
C10	270	GBI_6	B phase signal input of G video (sixth bit)
C9	271	GBI_0	B phase signal input of G video (0 bit)
C8	272	BBI_4	B phase signal input of B video (fourth bit)
C7	273	VDDIO	3.3V power supply
C6	274	RAI_9	A phase signal input of R video (ninth bit)
C5	275	RAI_3	A phase signal input of R video (third bit)
C4	276	GAI_8	A phase signal input of G video (eighth bit)
D4	277	GAI_7	A phase signal input of G video (seventh bit)
E4	278	GAI_6	A phase signal input of G video (sixth bit)
F4	279	GAI_5	A phase signal input of G video (fifth bit)
G4	280	VCMP	GND
H4	281	XSUSB_13	X-Drive control signal output
J4	282	XSUSB_11	X-Drive control signal output
K4	283	XSUSB_7	X-Drive control signal output
L4	284	XSUSB_1	X-Drive control signal output
M4	285	XSUSA_13	X-Drive control signal output
N4	286	XSUSA_7	X-Drive control signal output
P4	287	XSUSA_3	X-Drive control signal output
R4	288	ADRS_3	Address control signal output
T4	289	TESTAN	Test signal input (Not used)
U4	290	VDDLA	3.3V power supply
V4	291	VDDLA	3.3V power supply
W4	292	VDDLA	3.3V power supply
Y4	293	VDDLA	3.3V power supply
AA4	294	VDDLA	3.3V power supply
AB4	295	VDDLA	3.3V power supply
AC4	296	VDDLA	3.3V power supply
AC5	297	VDDLA	3.3V power supply
AC6	298	VDDLA	3.3V power supply
AC7	299	VDDLA	3.3V power supply
AC8	300	VDDLA	3.3V power supply

● Pin Function (7/10)

Ball No.	No.	Pin Name	Function
AC8	300	VDDLA	3.3V power supply
AC9	301	VDDLA	3.3V power supply
AC10	302	VDDLA	3.3V power supply
AC11	303	VDDLA	3.3V power supply
AC12	304	VDDLA	3.3V power supply
AC13	305	VDDLA	3.3V power supply
AC14	306	VDDDBG	3.3V power supply
AC15	307	VDDLA	3.3V power supply
AC16	308	VDDLA	3.3V power supply
AC17	309	VDDLA	3.3V power supply
AC18	310	VDDLA	3.3V power supply
AC19	311	VDDLA	3.3V power supply
AC20	312	VDDLA	3.3V power supply
AC21	313	VDDLA	3.3V power supply
AC22	314	VDDLA	3.3V power supply
AC23	315	VDDLA	3.3V power supply
AB23	316	VDDLA	3.3V power supply
AA23	317	VDDLA	3.3V power supply
Y23	318	VDDLA	3.3V power supply
W23	319	VDDLA	3.3V power supply
V23	320	VDDLA	3.3V power supply
U23	321	VDDLA	3.3V power supply
T23	322	SDITDI	JTAG signal
R23	323	GPIO0_6	Microcomputer macro general-purpose port
P23	324	GPIO0_2	Microcomputer macro general-purpose port
N23	325	YSUSA_1	Y-Drive control signal output
M23	326	YSUSA_7	Y-Drive control signal output
L23	327	YSUSA_13	Y-Drive control signal output
K23	328	YSUSB_1	Y-Drive control signal output
J23	329	YSUSB_5	Y-Drive control signal output
H23	330	YSUSB_9	Y-Drive control signal output
G23	331	VCMP	GND
F23	332	SCAN_0	Scan control signal output
E23	333	SCAN_4	Scan control signal output
D23	334	SCAN_7	Scan control signal output
D22	335	SCAN_8	Scan control signal output
D21	336	SCAN_9	Scan control signal output
D20	337	EXA11	Flash memory address bus
D19	338	EXA19	Flash memory address bus
D18	339	EXA4	Flash memory address bus
D17	340	EXDIO_0	Flash memory data bus
D16	341	EXDIO_4	Flash memory data bus
D15	342	EXDIO_8	Flash memory data bus
D14	343	EXDIO_14	Flash memory data bus
D13	344	RBI_7	B phase signal input of R video (seventh bit)
D12	345	RBI_2	B phase signal input of R video (second bit)
D11	346	GBI_9	B phase signal input of G video (ninth bit)
D10	347	GBI_5	B phase signal input of G video (fifth bit)
D9	348	BBI_9	B phase signal input of B video (ninth bit)
D8	349	BBI_3	B phase signal input of B video (tenth bit)

● Pin Function (8/10)

Ball No.	No.	Pin Name	Function
D7	350	DEI	DE signal input
D6	351	RAI_8	A phase signal input of R video (eighth bit)
D5	352	RAI_2	A phase signal input of R video (second bit)
E5	353	RAI_1	A phase signal input of R video (first bit)
F5	354	RAI_0	A phase signal input of R video (0 bit)
G5	355	BAI_0	A phase signal input of B video (0 bit)
H5	356	VSS15	GND
J5	357	VDDHR	3.3V power supply
K5	358	XSUSB_6	X-Drive control signal output
L5	359	VSSD15	GND
M5	360	XSUSA_12	X-Drive control signal output
N5	361	XSUSA_6	X-Drive control signal output
P5	362	VSS15	GND
R5	363	ADRS_2	Address control signal output
T5	364	TESTBN	Test signal input (Not used)
U5	365	VSSL15	GND
V5	366	VSSLA	GND
W5	367	VSSLA	GND
Y5	368	VSSL15	GND
AA5	369	VDDL15	3.3V power supply
AB5	370	VSSL15	GND
AB6	371	VSSLA	GND
AB7	372	VSSLA	GND
AB8	373	VSSL15	GND
AB9	374	VSSLA	GND
AB10	375	VSSLA	GND
AB11	376	VSSL15	GND
AB12	377	VSSLA	GND
AB13	378	VSSLA	GND
AB14	379	REFRIN	Reference current generation
AB15	380	VSSBG	GND
AB16	381	VSSL15	GND
AB17	382	VSSLA	GND
AB18	383	VSSLA	GND
AB19	384	VSSL15	GND
AB20	385	VSSLA	GND
AB21	386	VSSLA	GND
AB22	387	VSSLA	GND
AA22	388	VDDL15	3.3V power supply
Y22	389	VSSL15	GND
W22	390	VSSLA	GND
V22	391	VSSLA	GND
U22	392	VSSL15	GND
T22	393	SDITMS	JTAG signal
R22	394	GPIO0_5	Microcomputer macro general-purpose port
P22	395	VSS15	GND
N22	396	YSUSA_2	Y-Drive control signal output
M22	397	YSUSA_8	Y-Drive control signal output
L22	398	VSSD15	GND
K22	399	YSUSB_2	Y-Drive control signal output

● Pin Function (9/10)

Ball No.	No.	Pin Name	Function
J22	400	VDDHL	3.3V power supply
H22	401	VSSD15	GND
G22	402	YSUSB_12	Y-Drive control signal output
F22	403	SCAN_1	Scan control signal output
E22	404	SCAN_5	Scan control signal output
E21	405	SCAN_6	Scan control signal output
E20	406	VSS15	GND
E19	407	EXA18	Flash memory address bus
E18	408	EXA3	Flash memory address bus
E17	409	EXDIO_1	Flash memory data bus
E16	410	VSS15	GND
E15	411	EXDIO_9	Flash memory data bus
E14	412	EXDIO_15	Flash memory data bus
E13	413	RBI_6	B phase signal input of R video (sixth bit)
E12	414	CLKS	CLK input (85MHz)
E11	415	VSS15	GND
E10	416	GBI_4	B phase signal input of G video (fourth bit)
E8	418	BBI_2	B phase signal input of B video (second bit)
E9	417	BBI_8	B phase signal input of B video (eighth bit)
E7	419	VSS15	GND
E6	420	RAI_7	A phase signal input of R video (seventh bit)
F6	421	RAI_6	A phase signal input of R video (sixth bit)
G6	422	APL_DT	APL value trigger input
H6	423	VDD15	1.5V power supply
J6	424	VBB	VBB power monitor in the DRAM
K6	425	XSUSB_5	X-Drive control signal output
L6	426	VDDD15	1.5V power supply
M6	427	XSUSA_11	X-Drive control signal output
N6	428	XSUSA_5	X-Drive control signal output
P6	429	VDD15	1.5V power supply
R6	430	ADRS_1	Address control signal output
T6	431	TESTCN	Test signal input (Not used)
U6	432	VDDL15	1.5V power supply
V6	433	VDDLA	3.3V power supply
W6	434	VDDLA	3.3V power supply
Y6	435	VDDL15	1.5V power supply
AA6	436	VDDLA	3.3V power supply
AA7	437	VDDLA	3.3V power supply
AA8	438	VDDL15	1.5V power supply
AA9	439	VDDLA	3.3V power supply
AA10	440	VDDLA	3.3V power supply
AA11	441	VDDL15	1.5V power supply
AA12	442	VDDLA	3.3V power supply
AA13	443	VDDLA	3.3V power supply
AA14	444	VDDLA	3.3V power supply
AA15	445	VDDLA	3.3V power supply
AA16	446	VDDL15	1.5V power supply
AA17	447	VDDLA	3.3V power supply
AA18	448	VDDLA	3.3V power supply
AA19	449	VDDL15	1.5V power supply

● Pin Function (10/10)

Ball No.	No.	Pin Name	Function
AA20	450	VDDLA	3.3V power supply
AA21	451	VDDLA	3.3V power supply
Y21	452	VDDL15	1.5V power supply
W21	453	VDDLA	3.3V power supply
V21	454	VDDLA	3.3V power supply
U21	455	VDDL15	1.5V power supply
T21	456	SDITCK	JTAG signal
R21	457	GPIO0_4	Microcomputer macro general-purpose port
P21	458	VDD15	1.5V power supply
N21	459	YSUSA_3	Y-Drive control signal output
M21	460	YSUSA_9	Y-Drive control signal output
L21	461	VDDD15	1.5V power supply
K21	462	YSUSB_3	Y-Drive control signal output
J21	463	VBB	VBB power monitor in the DRAM
H21	464	VDDD15	1.5V power supply
G21	465	YSUSB_13	Y-Drive control signal output
F21	466	SCAN_2	Scan control signal output
F20	467	VDD15	1.5V power supply
F19	468	EXA17	Flash memory address bus
F18	469	EXA2	Flash memory address bus
F17	470	EXDIO_2	Flash memory data bus
F16	471	VDD15	1.5V power supply
F15	472	EXDIO_10	Flash memory data bus
F14	473	TRNSEND_I	NC pin
F13	474	VDD15	1.5V power supply
F12	475	RBI_1	B phase signal input of R video (first bit)
F11	476	VDD15	1.5V power supply
F10	477	GBI_3	B phase signal input of G video (third bit)
F9	478	BBI_7	B phase signal input of B video (seventh bit)
F8	479	BBI_1	B phase signal input of B video (first bit)
F7	480	VDD15	1.5V power supply

■ **AN5870SB (RGB ASSY : IC6402)**
(AV I/O ASSY : IC7610, IC7613)
(VIDEO SLOT1 ASSY : IC7902)
(VIDEO SLOT2 ASSY : IC7902)

- Wide Band Analog SW

● **Pin Arrangement / Block Diagram**

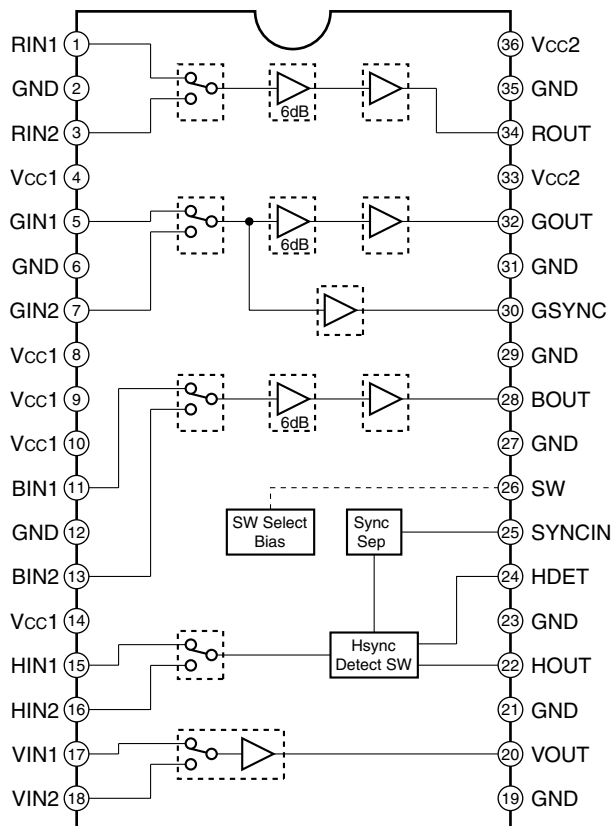

● **Pin Function**

No.	Name	Function	No.	Name	Function
1	RIN1	R input 1	19	GND	Ground (HV, HSEP, SW)
2	GND	Ground (R)	20	VOUT	V output
3	RIN2	R input 2	21	GND	Ground
4	Vcc1	5V (GSYNC)	22	HOUT	H output
5	GIN1	G input 1	23	GND	Ground
6	GND	Ground (G)	24	HDET	H detect
7	GIN2	G input 2	25	SYNCIN	Sync input
8	Vcc1	5V (R)	26	SW	SW
9	Vcc1	5V (G)	27	GND	Ground
10	Vcc1	5V (B)	28	BOUT	B output
11	BIN1	B input 1	29	GND	Ground (RGB)
12	GND	Ground (B)	30	GSYNC	GSync output
13	BIN2	B input 2	31	GND	Ground (RGB)
14	Vcc1	5V (HV, HSEP, SW)	32	GOUT	G output
15	HIN1	H input 1	33	Vcc2	12V (RGB)
16	HIN2	H input 2	34	ROUT	R output
17	VIN1	V input 1	35	GND	Ground
18	VIN2	V input 2	36	Vcc2	12V (RGB)

AD9883AKST-110 (RGB ASSY : IC6602)

• 110 MSPS Analog Interface

● Pin Arrangement (Top View)

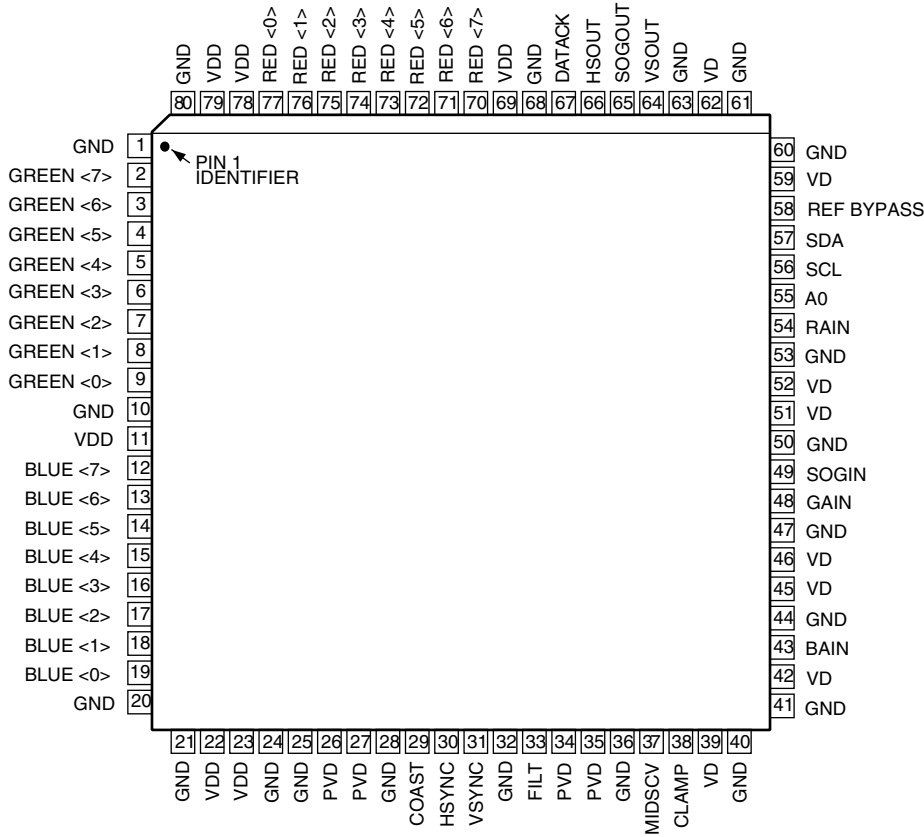

● Block Diagram

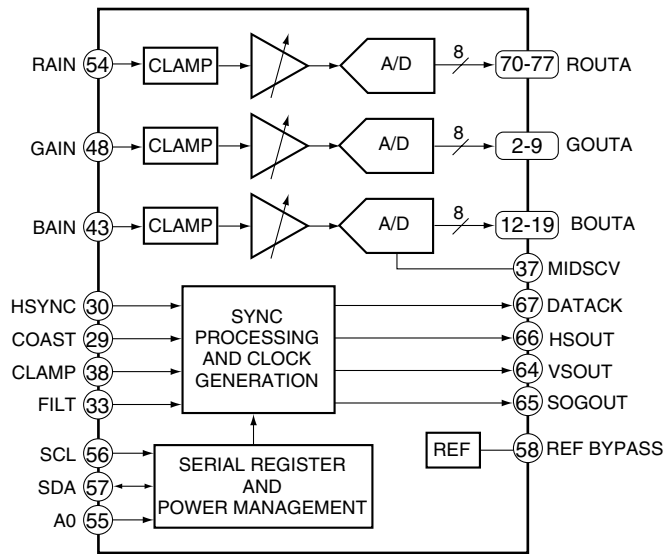

● Pin Function

No.	Pin Name	I/O	Pin Function
1	GND	–	Ground
2	GREEN 7	O	Converter Green output (MSB)
3	GREEN 6	O	Converter Green output
4	GREEN 5	O	Converter Green output
5	GREEN 4	O	Converter Green output
6	GREEN 3	O	Converter Green output
7	GREEN 2	O	Converter Green output
8	GREEN 1	O	Converter Green output
9	GREEN 0	O	Converter Green output
10	GND	–	Ground
11	VDD	–	Power supply (3.3V)
12	BLUE 7	O	Converter Blue output (MSB)
13	BLUE 6	O	Converter Blue output
14	BLUE 5	O	Converter Blue output
15	BLUE 4	O	Converter Blue output
16	BLUE 3	O	Converter Blue output
17	BLUE 2	O	Converter Blue output
18	BLUE 1	O	Converter Blue output
19	BLUE 0	O	Converter Blue output
20	GND	–	Ground
21	GND	–	Ground
22	VDD	–	Power supply (3.3V)
23	VDD	–	Power supply (3.3V)
24	GND	–	Ground
25	GND	–	Ground
26	PVD	–	PLL power supply (3.3V)
27	PVD	–	PLL power supply (3.3V)
28	GND	–	Ground
29	COAST	I	PLL COAST signal input
30	HSYNC	I	Horizontal sync. input
31	VSYNC	I	Vertical sync. input
32	GND	–	Ground
33	FILT	–	External filter connection pin for built-in PLL
34	PVD	–	PLL power supply (3.3V)
35	PVD	–	PLL power supply (3.3V)
36	GND	–	Ground
37	MIDSCV	–	Internal middle scale voltage bias
38	CLAMP	I	Clamp input (External clamp signal)
39	VD	–	Analog power supply (3.3V)
40	GND	–	Ground
41	GND	–	Ground
42	VD	–	Analog power supply (3.3V)
43	BAIN	I	Analog input for converter B
44	GND	–	Ground
45	VD	–	Analog power supply (3.3V)

No.	Pin Name	I/O	Pin Function
A 46	VD	–	Analog power supply (3.3V)
47	GND	–	Ground
48	GAIN	I	Analog input for converter G
49	SOGIN	I	Input for Sync-on Green
50	GND	–	Ground
51	VD	–	Analog power supply (3.3V)
52	VD	–	Analog power supply (3.3V)
53	GND	–	Ground
54	RAIN	I	Analog input for converter R
B 55	A0	I	Address input 1 of serial port
56	SCL	I	Data clock (max. 100kHz) of serial port
57	SDA	I/O	Data input/output of serial port
58	REF BYPASS	–	Internal reference bypass
59	VD	–	Analog power supply (3.3V)
60	GND	–	Ground
61	GND	–	Ground
62	VD	–	Analog power supply (3.3V)
63	GND	–	Ground
C 64	VSOUT	O	VSYNC output (phasing with DATACLK)
65	SOGOUT	O	Sync-on-Green slicer output
66	HSOUT	O	HSYNC output (phasing with DATACLK)
67	DATACLK	O	Data input/output clock
68	GND	–	Ground
69	VDD	–	Power supply (3.3V)
70	RED 7	O	Converter Red output (MSB)
71	RED 6	O	Converter Red output
72	RED 5	O	Converter Red output
D 73	RED 4	O	Converter Red output
74	RED 3	O	Converter Red output
75	RED 2	O	Converter Red output
76	RED 1	O	Converter Red output
77	RED 0	O	Converter Red output
78	VDD	–	Power supply (3.3V)
79	VDD	–	Power supply (3.3V)
80	GND	–	Ground

E

F

SM5301BS (RGB ASSY : IC6601)

• Video Filter

• Block Diagram

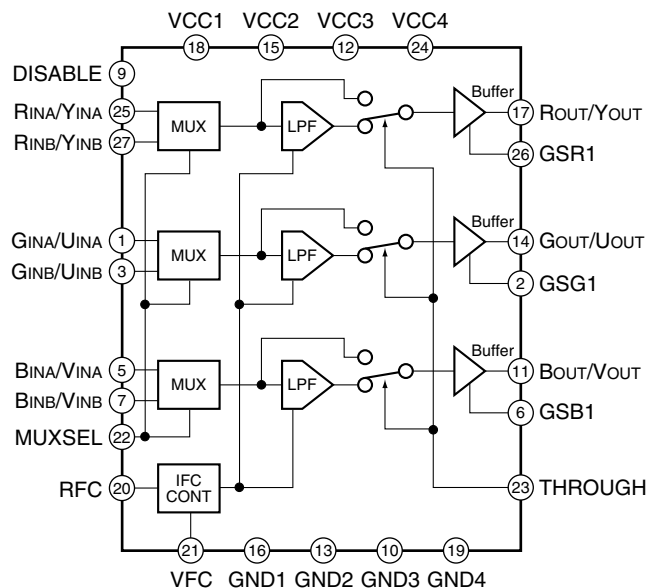

• Pin Arrangement (Top View)

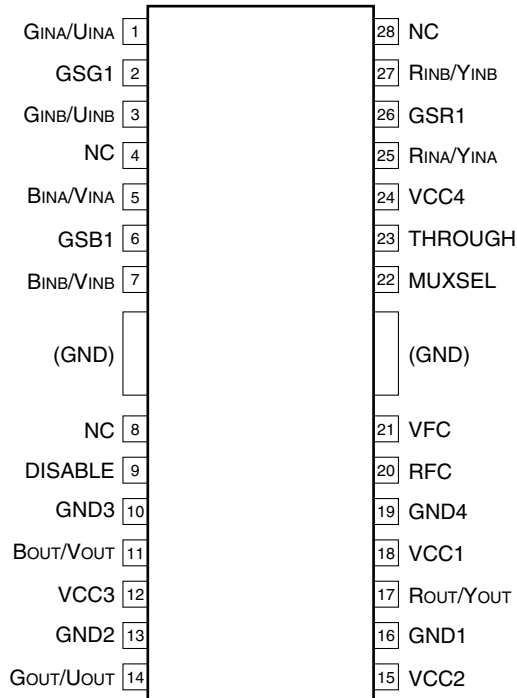

A
B
C
D
E
F

● Pin Function

No.	Pin Name	I/O	Pin Function
A 1	GINA/UINA	I	Analog GINA or UINA signal input. Sync signal is input on SYNCIN pin.
2	GSG1	I	GOUT/UOUT output buffer gain set input
3	GINB/UINB	I	Analog GINB or UINB signal input. Sync signal is input on SYNCIN pin.
4	(NC)	–	No connection
5	BINA/VINA	I	Analog BINA or VINA signal input. Sync signal is input on SYNCIN pin.
6	GSB1	I	BOUT/VOUT output buffer gain set input
B 7	BINB/VINB	I	Analog BINB or VINB signal input. Sync signal is input on SYNCIN pin.
8	(NC)	–	No connection
9	DISABLE	I	Power save function. Built-in pull-down resistor. L : Enable H : Disable (Output pins: ROUT/YOUT, GOUT/UOUT, and BOUT/VOUT are high impedance.)
10	GND3	–	Analog ground
11	BOUT/VOUT	O	B/V signal output
12	VCC3	–	Analog 5V supply
13	GND2	–	Analog ground
C 14	GOUT/UOUT	O	G/U signal output
15	VCC2	–	Analog 5V supply
16	GND1	–	Analog ground
17	ROUT/YOUT	O	R/Y signal output
18	VCC1	–	Analog 5V supply
19	GND4	–	Analog ground
20	RFC	–	LPF (lowpass filter) cutoff frequency setting resistor connection
21	VFC	I	LPF (lowpass filter) cutoff frequency setting voltage input
D 22	MUXSEL	I	Input select signal. Built-in pull-down resistor. L : XINA pin select H : XINB pin select
23	THROUGH	I	Filter through Built-in pull-down resistor. L : Filter function H : Filter through (buffer only)
24	VCC4	–	Analog 5V supply
25	RINA/YINA	I	Analog RINA or YINA signal input. Sync signal is input on SYNCIN pin.
26	GSR1	I	ROUT/YOUT output buffer gain set input
E 27	RINB/YINB	I	Analog RINB or YINB signal input. Sync signal is input on SYNCIN pin.
28	(NC)	–	No connection

BA7078AF (RGB ASSY : IC6604)

• Synchronous separation IC

● Block Diagram

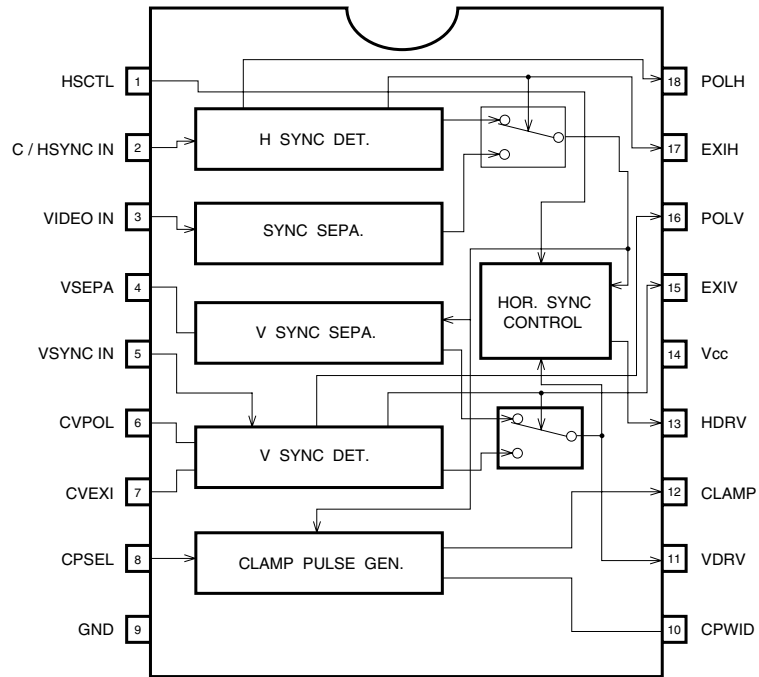

A
B
C
D
E
F

● Pin Function

No.	Pin Name	Pin Function
A 1	HSCTL	HDRV output Used to select whether to output the VDRV section of the HDRV output signal. High : VDRV section of HDRV is output Low : VDRV section of HDRV is not output
2	C/HSYNC IN	Composite sync / H SYNC input Input either the composite synchronization signal or the horizontal synchronization signal. Input is clamped, and is initiated by capacitor coupling.
3	VIDEO IN	SYNC ON VIDEO input Inputs the SYNC ON VIDEO signal(green). Input is sink chip clamped. Input is initiated by capacitor coupling.
B 4	VSEPA	f-V conversion Converts the horizontal synchronization signal frequency into a voltage. The voltage generated is proportional to the frequency of the horizontal synchronization signal. Attach a 0.56 μ F capacitor between the ground pins.
5	VSYNC IN	V SYNC input Inputs the vertical synchronization signal.
6	CVPOL	Vertical polarity integration Integrates the vertical synchronization signal polarity detection circuit. Attach a 1.5 μ F capacitor between this pin and the ground.
7	CVEXI	Vertical existence integration Integrates the vertical synchronization signal existence detection circuit. Attach a 1 μ F capacitor between this pin and the ground.
C 8	CPSEL	Setting the clamp position Used to set the clamp pulse generation position to either the front or back edge of HSYNC High : The front edge is the generation position Open : Composite / H SYNC IN : The front edge is the generation position VIDEO IN : The back edge is the generation position Low : The back edge is the generation position
9	GND	Ground
10	CPWID	Setting the clamp pulse width Sets the clamp pulse width according to the attached time constant. Attach a resistor between this pin and VCC and, a capacitor between this pin and GND. When R = 3.9k Ω and C = 100pF, pulse width is approximately 400 ns. Set the resistor to register an abnormality at 1k Ω .
D 11	VDRV	VDRV output Outputs the vertical synchronization signal. The output signal has positive polarity.
12	CLAMP	Clamp output Outputs the clamp pulse generated from the vertical synchronization signal. The output signal has a positive polarity.
13	HDRV	HDRV output Outputs the clamp pulse generated from the horizontal synchronization signal. The output signal has positive polarity.
14	Vcc	Power supply
15	EXIV	Vertical existence output Indecates whether the vertical synchronization signal exists.
16	POLV	Vertical polarity output Indicates the polarity of the vertical synchronization signal.
E 17	EXIH	Horizontal existence output Indicates whether the horizontal synchronization signal exists.
18	POLH	Horizontal polarity output Indicates the polarity of the horizontal synchronization signal.

IC42S32200-7TG-K (RGB ASSY : IC7001, IC7002)

• Synchronous DRAM

● Block Diagram

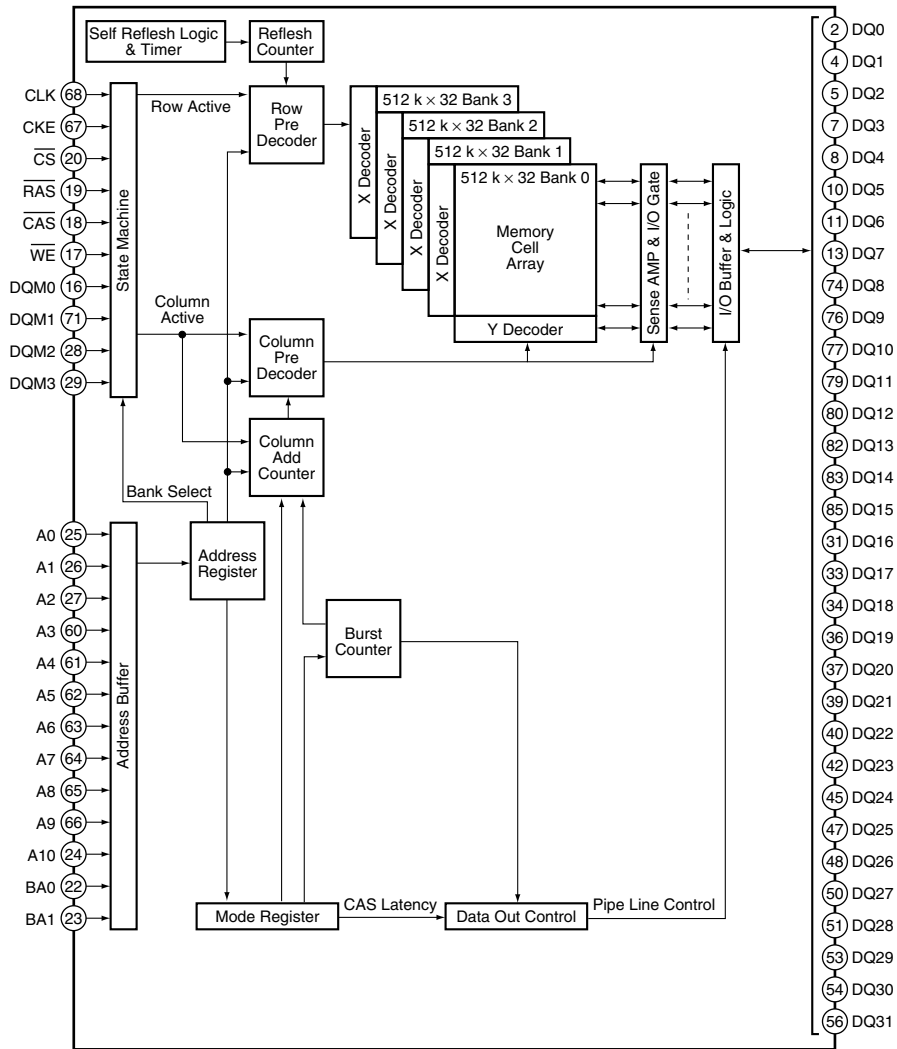

● Pin Function

No.	Pin Name	I/O	Pin Function	No.	Pin Name	I/O	Pin Function
1	VDD	–	Power supply	44	VSS	–	Ground
2	DQ0	I/O	Data input/output	45	DQ24	I/O	Data input/output
3	VDDQ	–	Power supply for output buffer	46	VSSQ	–	Ground for output buffer
4	DQ1	I/O	Data input/output	47	DQ25	I/O	Data input/output
5	DQ2	I/O	Data input/output	48	DQ26	I/O	Data input/output
6	VSSQ	–	Ground for output buffer	49	VDDQ	–	Power supply for output buffer
7	DQ3	I/O	Data input/output	50	DQ27	I/O	Data input/output
8	DQ4	I/O	Data input/output	51	DQ28	I/O	Data input/output
9	VDDQ	–	Power supply for output buffer	52	VSSQ	–	Ground for output buffer
10	DQ5	I/O	Data input/output	53	DQ29	I/O	Data input/output
11	DQ6	I/O	Data input/output	54	DQ30	I/O	Data input/output
12	VSSQ	–	Ground for output buffer	55	VDDQ	–	Power supply for output buffer
13	DQ7	I/O	Data input/output	56	DQ31	I/O	Data input/output
14	NC	–	No connection	57	NC	–	No connection
15	VDD	–	Power supply	58	VSS	–	Ground
16	DQM0	I	Data input/output mask	59	DQM3	I	Data input/output mask
17	/WE	I	Write enable	60	A3	I	Address input
18	/CAS	I	Column address strobe	61	A4	I	Address input
19	/RAS	I	Row address strobe	62	A5	I	Address input
20	/CS	I	Chip select input	63	A6	I	Address input
21	NC	–	No connection	64	A7	I	Address input
22	BA0	I	Bank address input	65	A8	I	Address input
23	BA1	I	Bank address input	66	A9	I	Address input
24	A10/AP	I	Address input	67	CKE	I	Clock enable
25	A0	I	Address input	68	CLK	I	System clock input
26	A1	I	Address input	69	NC	–	No connection
27	A2	I	Address input	70	NC	–	No connection
28	DQM2	I	Data input/output mask	71	DQM1	I	Data input/output mask
29	VDD	–	Power supply	72	VSS	–	Ground
30	NC	–	No connection	73	NC	–	No connection
31	DQ16	I/O	Data input/output	74	DQ8	I/O	Data input/output
32	VSSQ	–	Ground for output buffer	75	VDDQ	–	Power supply for output buffer
33	DQ17	I/O	Data input/output	76	DQ9	I/O	Data input/output
34	DQ18	I/O	Data input/output	77	DQ10	I/O	Data input/output
35	VDDQ	–	Power supply for output buffer	78	VSSQ	–	Ground for output buffer
36	DQ19	I/O	Data input/output	79	DQ11	I/O	Data input/output
37	DQ20	I/O	Data input/output	80	DQ12	I/O	Data input/output
38	VSSQ	–	Ground for output buffer	81	VDDQ	–	Power supply for output buffer
39	DQ21	I/O	Data input/output	82	DQ13	I/O	Data input/output
40	DQ22	I/O	Data input/output	83	DQ14	I/O	Data input/output
41	VDDQ	–	Power supply for output buffer	84	VSSQ	–	Ground for output buffer
42	DQ23	I/O	Data input/output	85	DQ15	I/O	Data input/output
43	VDD	–	Power supply	86	VSS	–	Ground

MBM29PL3200BE70PFV (RGB ASSY : IC7152)

• Page Mode Flash Memory

● Block Diagram

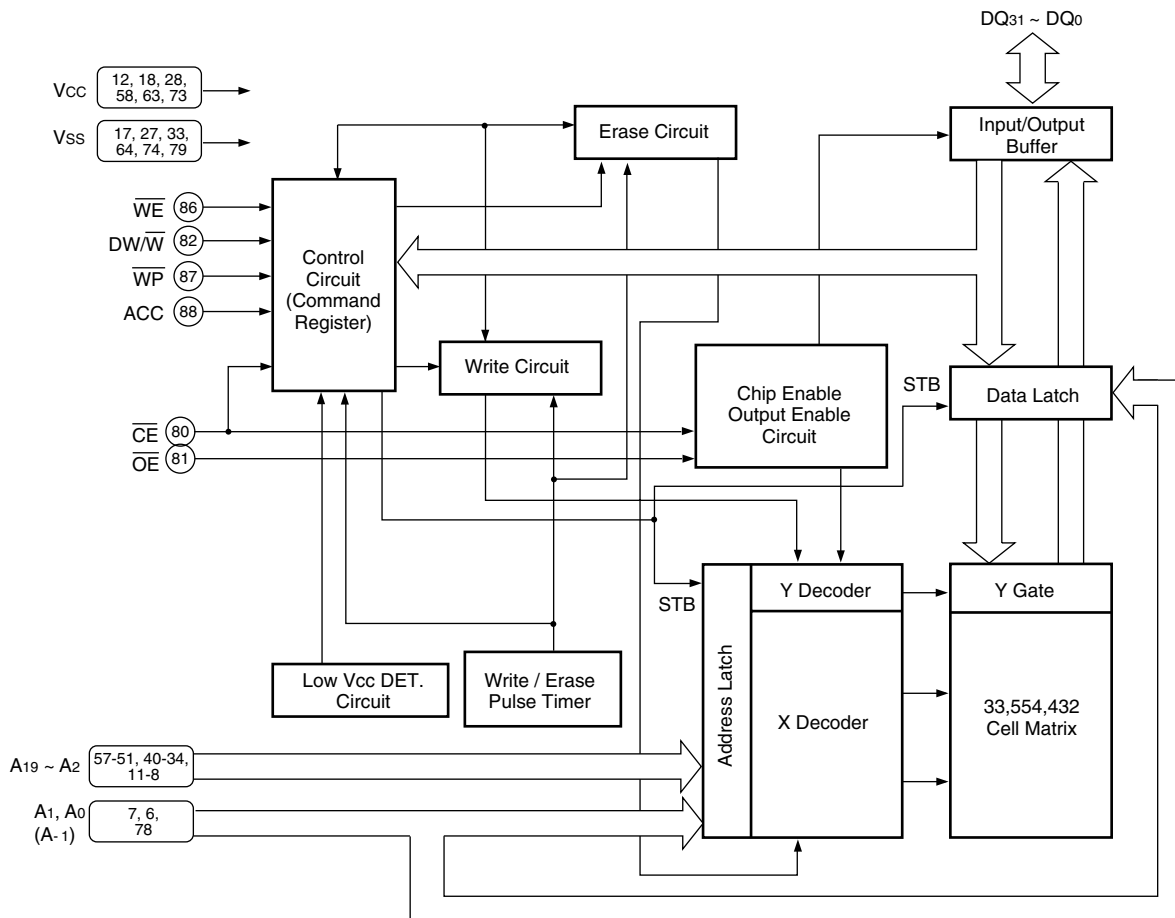

● Pin Function

No.	Pin Name	I/O	Pin Function
57-51, 40-34, 11-6, 78	A ₁₉ - A ₀ , A-1	I	Address input
78-75, 72-65, 62-59, 32-19, 26-19, 16-13	DQ ₃₁ - DQ ₀	I/O	Data input/output
80	CE	I	Chip enable
81	OE	I	Output enable
86	WE	I	Write enable
82	DW/W	I	16 bit, 32 bit mode switch
87	WP	I	Write protect
88	ACC	I	Acceleration
17, 27, 33, 64, 74, 79	V _{SS}	-	Ground
12, 18, 28, 58, 63, 73	V _{CC}	-	Power supply
1-5, 41-50, 83-85, 89, 90	N.C.	-	No connection

CXA3516AR (RGB ASSY : IC6001)

• AD + PLL IC

A

● Pin Arrangement (Top View)

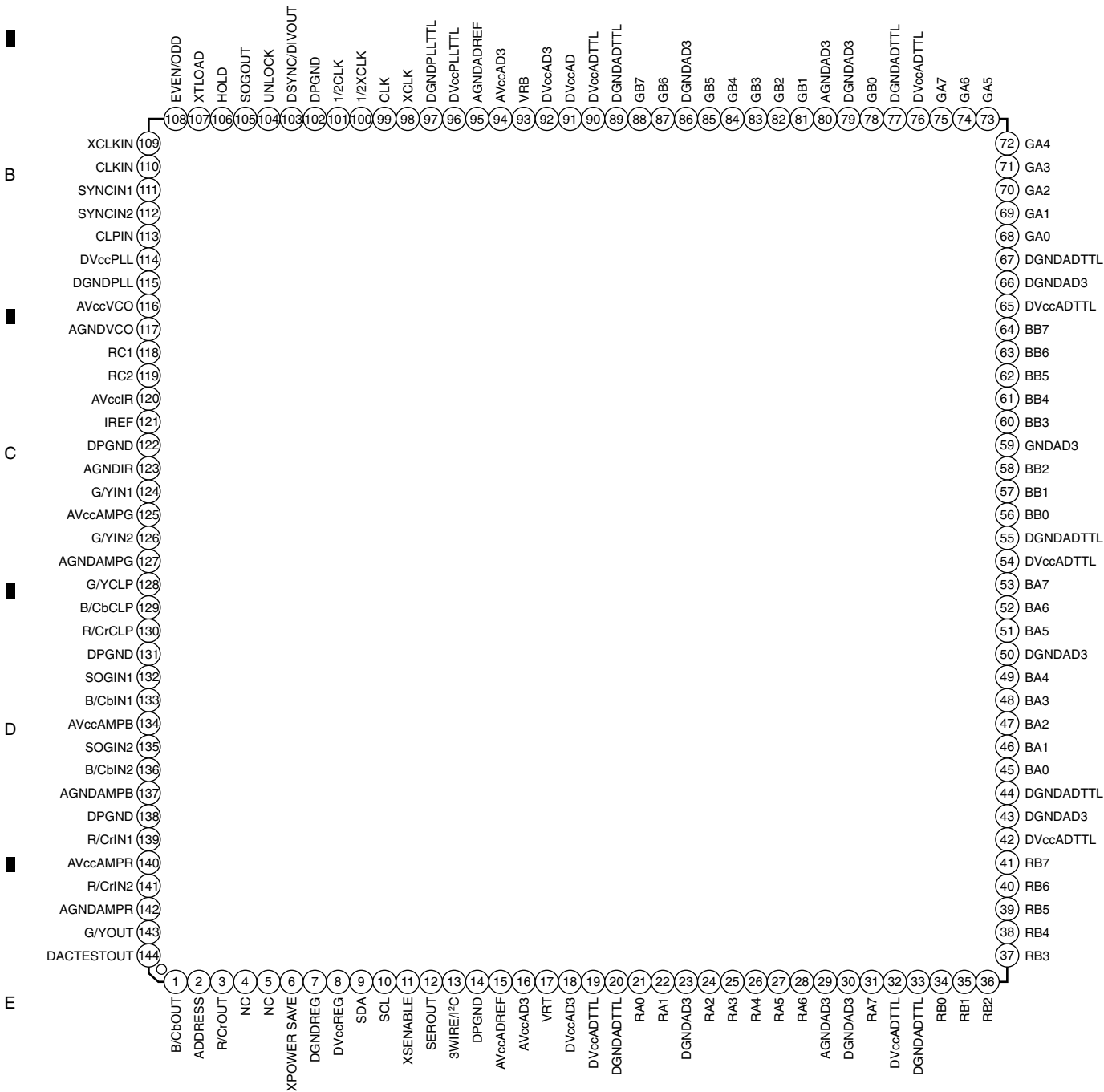

F

● Block Diagram

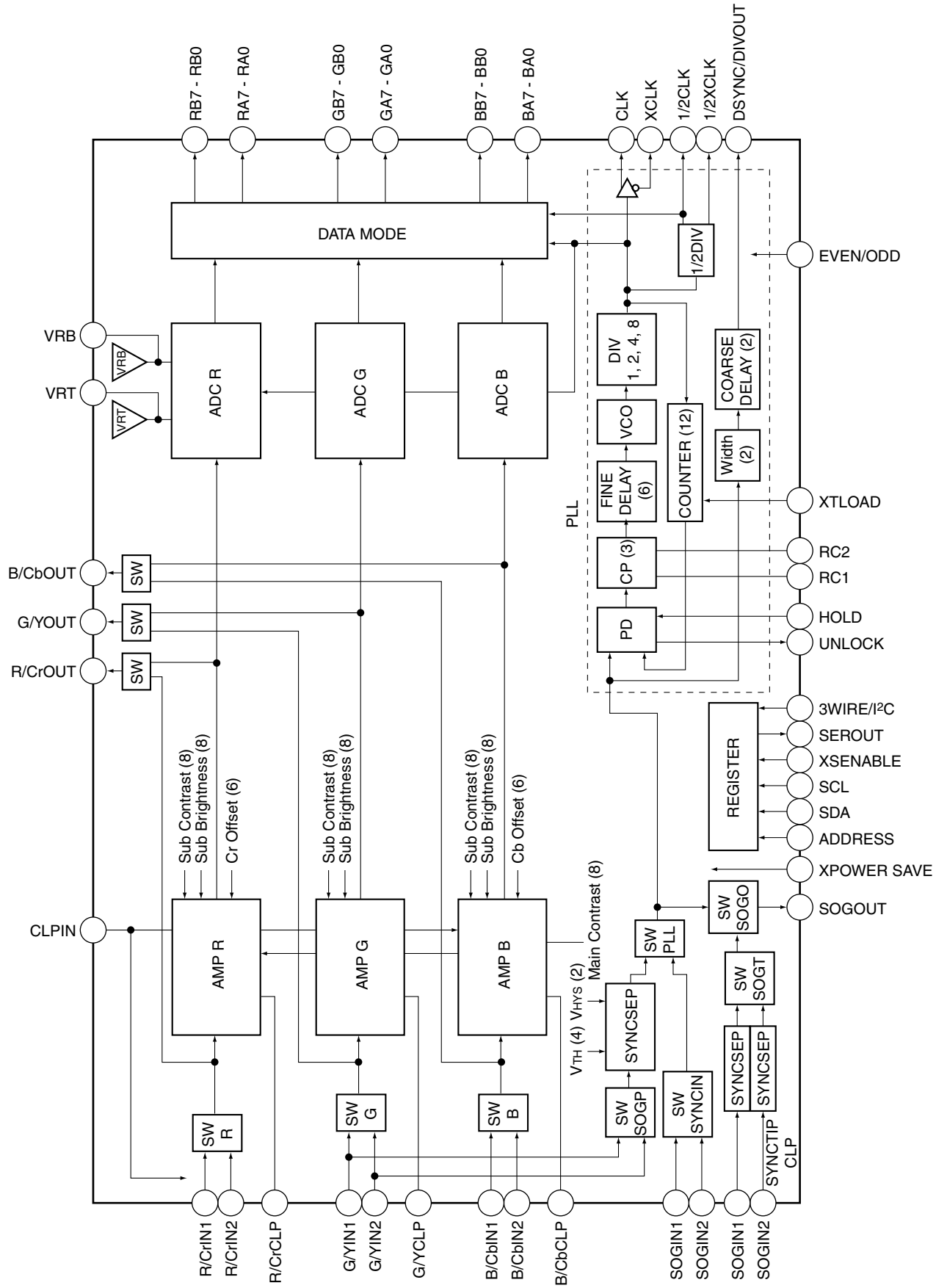

● Pin Function

No.	Symbol	I/O	Pin Function
1	B/CbOUT	O	Amplifier output signal monitor
2	ADDRESS	I	I ² C slave address setting
3	R/CrOUT	O	Amplifier output signal monitor
4	NC	–	Not used
5	NC	–	Not used
6	XPOWER SAVE	I	Power save setting
7	DGNDREG	–	Register GND
8	DVccREG	–	Register power supply
9	SDA	I	Control register data input
10	SCL	I	Control register CLK input
11	XSENABLE	I	Enable signal input for 3-wire control register
12	SEROUT	O	3-wire control register data readout
13	3WIRE/I ² C	I	Selection of input between I ² C bus and 3-wire bus
15	AVccADREF	–	Reference power supply for A/D converter
16, 94	AVccAD3	–	Analog power supply for A/D converter
17	VRT	O	Top reference voltage output for A/D converter
18, 92	DVccAD3	–	Digital power supply for A/D converter
19, 32, 42, 54, 65, 76, 90	DVccADTTL	–	TTL output power supply for A/D converter
20, 33, 44, 55, 67, 77, 89	DGNDADTTL	–	TTL output GND for A/D converter
21, 22, 24-28, 31	RA0 - RA7	O	Data output for R-channel port A side
23, 30, 43, 50, 59, 66, 79, 86	DGNDAD3	–	Digital GND for A/D converter
29, 80	AGNDAD3	–	Analog GND for A/D converter
34-41	RB0 - RB7	O	Data output for R-channel port B side
45-49, 51-53	BA0 - BA7	O	Data output for B-channel port A side
56-58, 60-64	BB0 - BB7	O	Data output for B-channel port B side
68-75	GA0 - GA7	O	Data output for G-channel port A side
78, 81-85, 87, 88	GB0 - GB7	O	Data output for G-channel port B side
91	DVccAD	–	Digital power supply for A/D converter
93	VRB	O	Bottom reference voltage output for A/D converter
95	AGNDADREF	–	Reference voltage GND for A/D converter
96	DVccPLL	–	TTL output power supply for PLL
97	DGNDPLL	–	TTL output GND for PLL
98	XCLK	O	Inverted CLK output
99	CLK	O	CLK output
100	1/2XCLK	O	Inverted 1/2CLK output
101	1/2CLK	O	1/2CLK output
103	DSYNC/DIVOUT	O	DSYNC or DIVOUT signal output
104	UNLOCK	O	Unlock signal output
105	SOGOUT	O	Output for SYNC ON GREEN
106	HOLD	I	Input for phase comparison disable signal

No.	Symbol	I/O	Pin Function
107	XTLOAD	I	Programmable counter reset setting
108	EVEN/ODD	I	Inverted pulse input of ADC sampling CLK
109	XCLKIN	I	Inverted CLK input for testing
110	CLKIN	I	CLK input for testing
111	SYNCIN1	I	Sync input 1
112	SYNCIN2	I	Sync input 2
113	CLPIN	I	Clamp pulse input
114	DVccPLL	–	Digital power supply for PLL
115	DGNDPLL	–	Digital GND for PLL
116	AVccVCO	–	Analog power supply for PLL VCO
117	AGNDVCO	–	Analog GND for PLL VCO
118	RC1	–	External pin for PLL loop filter
119	RC2	–	External pin for PLL loop filter
120	AVccIR	–	Analog power supply for IREF
121	IREF	I	Current setup
123	AGNDIR	–	Analog GND for TREF
124	G/YIN1	I	G/Y signal input 1
125	AVccAMPG	–	Power supply for G/Y amplifier block
126	G/YIN2	I	G/Y signal input 2
127	AGNDAMPG	–	GND for G/Y amplifier block
128	G/YCLP	–	Clamp capacitor for brightness
129	B/CbCLP	–	Clamp capacitor for brightness
130	R/CrCLP	–	Clamp capacitor for brightness
132	SOGIN1	I	SYNC ON GREEN signal input 1
133	B/CbIN1	I	B/Cb signal input 1
134	AVccAMPB	–	Power supply for B/Cb amplifier block
135	SOGIN2	I	SYNC ON GREEN signal input 2
136	B/CbIN2	I	B/Cb signal input 2
137	AGNDAMPB	–	GND for B/Cb amplifier block
139	R/CrIN1	I	R/Cr signal input 1
140	AVccAMPR	–	Power supply for R/Cr amplifier block
141	R/CrIN2	I	R/Cr signal input 2
142	AGNDAMPR	–	GND for R/Cr amplifier block
143	G/YOUT	O	Monitor pin for amplifier output signal
144	DAC TEST OUT	O	DAC testing output for amplifier block control register
14, 102, 122, 131, 138	DPGND	–	GND

SII1161CTU-K (AV I/O ASSY : IC7503)

• Panel Link Receiver IC

A

● Pin Arrangement (Top View)

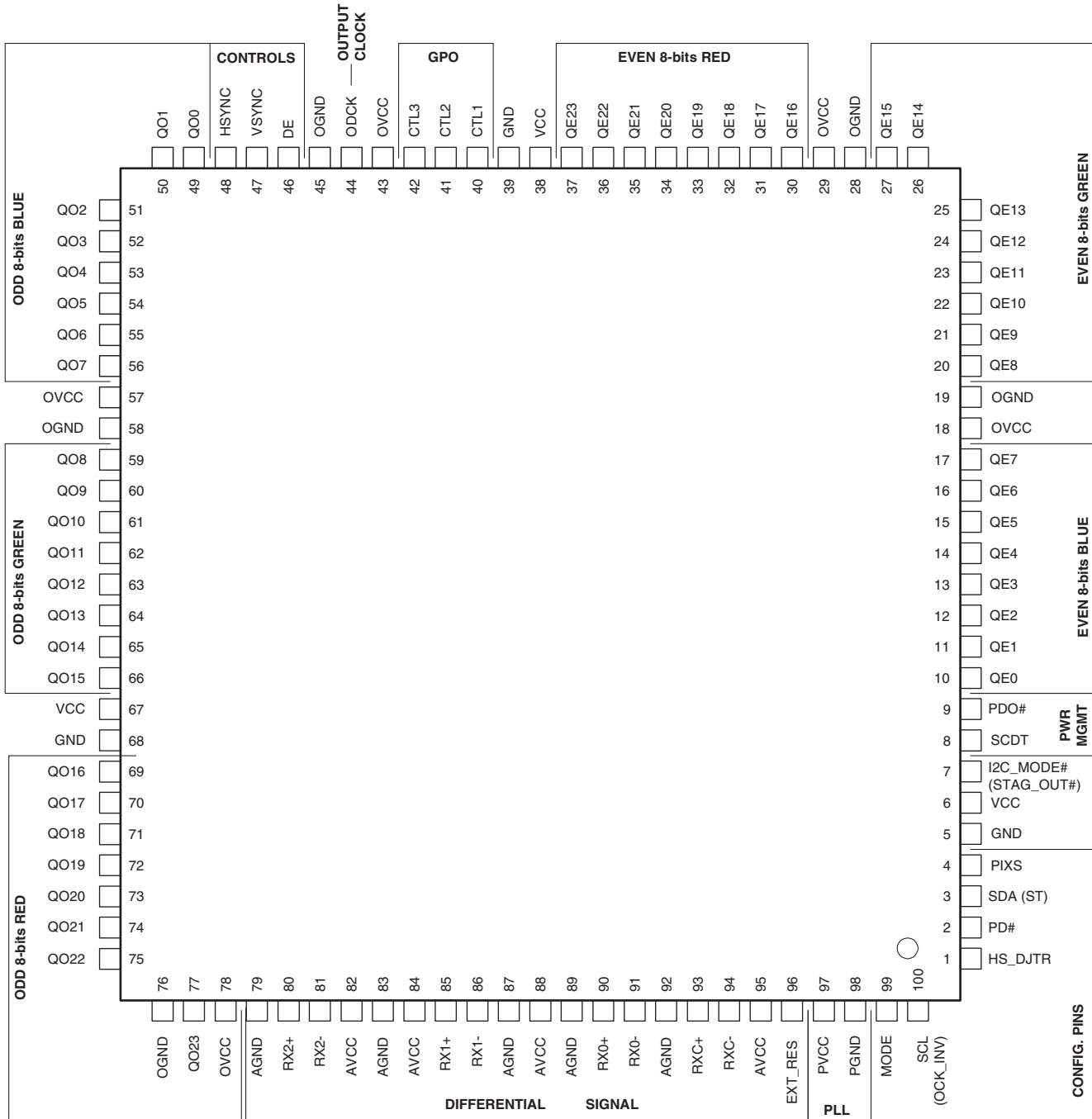

E

F

● Pin Function

Output Pins

Pin Name	No.	Type	Function
QE23 - QE0	37-30, 27-20, 17-10	Out	Output Even Data[23:0] corresponds to 24-bit pixel data for one pixel per clock input mode and to the first 24-bit pixel data for two pixels per clock mode. Output data is synchronized with output data clock (ODCK). Refer to the TFT Panel Data Mapping section, which tabulates the relationship between the input data to the transmitter and output data from the receiver. A low level on PD# or PDO# will put the output drivers into a high impedance (tri-state) mode. A weak internal pull-down device brings each output to ground.
QO23 - QO0	77, 75-69, 66-59, 56-49	Out	Output Odd Data[23:0] corresponds to the second 24-bit pixel data for two pixels per clock mode. During one pixel per clock mode, these outputs are driven low. Output data is synchronized with output data clock (ODCK). Refer to the TFT Panel Data Mapping section, which tabulates the relationship between the input data to the transmitter and output data from the receiver. A low level on PD# or PDO# will put the output drivers into a high impedance (tri-state) mode. A weak internal pull-down device brings each output to ground.
ODCK	44	Out	Output Data Clock. This output can be inverted using the OCK_INV pin. A low level on PD# or PDO# will put the output driver into a high impedance (tri-state) mode. A weak internal pulldown device brings the output to ground.
DE	46	Out	Output Data Enable. This signal qualifies the active data area. A HIGH level signifies active display time and a LOW level signifies blanking time. This output signal is synchronized with the output data. A low level on PD# or PDO# will put the output driver into a high impedance (tri-state) mode. A weak internal pull-down device brings the output to ground.
HSYNC VSYNC CTL1 CTL2 CTL3	48 47 40 41 42	Out	Horizontal Sync output control signal. Vertical Sync output control signal. General output control signal 1. This output is not powered down by PDO#. General output control signal 2. General output control signal 3. A low level on PD# or PDO# will put the output drivers (except CTL1 by PDO#) into a high impedance (tri-state) mode. A weak internal pull-down device brings each output to ground.

Differential Signal Data Pins

Pin Name	No.	Type	Function
RX0+ RX0- RX1+ RX1- RX2+ RX2-	90 91 85 86 80 81	Analog	Receiver Differential Data Pins. TMDS Low Voltage Differential Signal input data pairs.
RXC+ RXC-	93 94	Analog	Receiver Differential Clock Pins. TMDS Low Voltage Differential Signal input clock pair.
EXT_RES	96	Analog	Impedance Matching Control. An external 390Ω resistor must be connected between AVCC and this pin.

Configuration Pins

Pin Name	No.	Type	Function
MODE	99	In	Mode Select Pin. Used to select between drop-in strap-selected operation, or register programmable operation. To activate register-programmable operation, tie both pin 99 and pin 7 LOW. HIGH=161B (Compatible) Mode – strap selections are used to set part operation. Internal registers controlling non strap-selectable functions are reset to their default values. LOW=1161 (Programmable) Mode – I ² C registers are used to program part operation.
OOCK_INV	100	In	ODCK Polarity. A LOW level selects normal ODCK output. A HIGH level selects inverted ODCK output. All other output signals are unaffected by this pin. They will maintain the same timing no matter the setting of OOCK_INV pin
SCL			I ² C Port Clock. When pins 99 and 7 are tied LOW, pin 100 functions as an I ² C port input clock. The slave I ² C function does not ever try to extend cycles by pulling this pin low, so the pin remains input-only at all times. This pin accepts 3.3V signaling only; it is not 5V-tolerant.
PIXS	4	In	Pixel Select. A LOW level indicates one pixel (up to 24-bits) per clock mode using QE[23:0]. A HIGH level indicates two pixels (up to 48-bits) per clock mode using QE[23:0] for first pixel and QO[23:0] for second pixel.
STAG_OUT#	7	In	Staggered Output. A HIGH level selects normal simultaneous outputs on all odd and even data lines. A LOW level selects staggered output drive. This function is only available in two pixels per clock mode.
I2C_MODE#			This pin must be tied LOW to put the receiver into I ² C mode.
ST	3	In/Out	Output Drive. A HIGH level selects HIGH output drive strength. A LOW level selects LOW output drive strength.
SDA			I ² C Port Data. When pins 99 and 7 are tied LOW, pin 3 functions as an I ² C port data I/O signal. This pin accepts 3.3V signaling only; it is not 5V-tolerant.
HS_DJTR	1	In	HSYNC De-jitter. This pin enables/disables the HSYNC de-jitter function. To enable the HSYNC de-jitter function this pin should be HIGH. To disable the HSYNC de-jitter function this pin should be LOW.

Power Management Pins

Pin Name	No.	Type	Function
SCDT	8	Out	Sync Detect. A HIGH level is outputted when DE is actively toggling indicating that the link is alive. A LOW level is outputted when DE is inactive, indicating the link is down. Can be connected to PDO# to power down the outputs when DE is not detected. The SCDT output itself, however, remains in the active mode at all times.
PDO#	9	In	Output Driver Power Down (active LOW). A HIGH level indicates normal operation. A LOW level puts all the output drivers only (except SCDT and CTL1) into a high impedance (tri-state) mode. A weak internal pull-down device brings each output to ground. PDO# is a sub-set of the PD# description. The chip is not in power-down mode with this pin. SCDT and CTL1 are not tri-stated by this pin.
PD#	2	In	Power Down (active LOW). A HIGH level indicates normal operation. A LOW level indicates power down mode. During power down mode, all the output drivers are put into a high impedance (tri-state) mode. A weak internal pull-down device brings each output to ground. Additionally, all analog logic is powered down, and all inputs are disabled. Driving PD# LOW disables all internal logic and outputs, including SCDT and clock detect functions; it also resets all internal programmable registers to their default states.

Power and Ground Pins

Pin Name	No.	Type	Function
VCC	6, 38, 67	Power	Digital Core VCC, must be set to 3.3V.
GND	5, 39, 68	Ground	Digital Core GND.
OVCC	18, 29, 43, 57, 78	Power	Output VCC, must be set to 3.3V.
OGND	19, 28, 45, 58, 76	Ground	Output GND.
AVCC	82, 84, 88, 95	Power	Analog VCC must be set to 3.3V.
AGND	79, 83, 87, 89, 92	Ground	Analog GND.
PVCC	97	Power	PLL Analog VCC must be set to 3.3V.
PGND	98	Ground	PLL Analog GND.

LA4625 (AUDIO AMP ASSY : IC5003)

• 2ch BLT AF Power Amp. IC

● Block Diagram

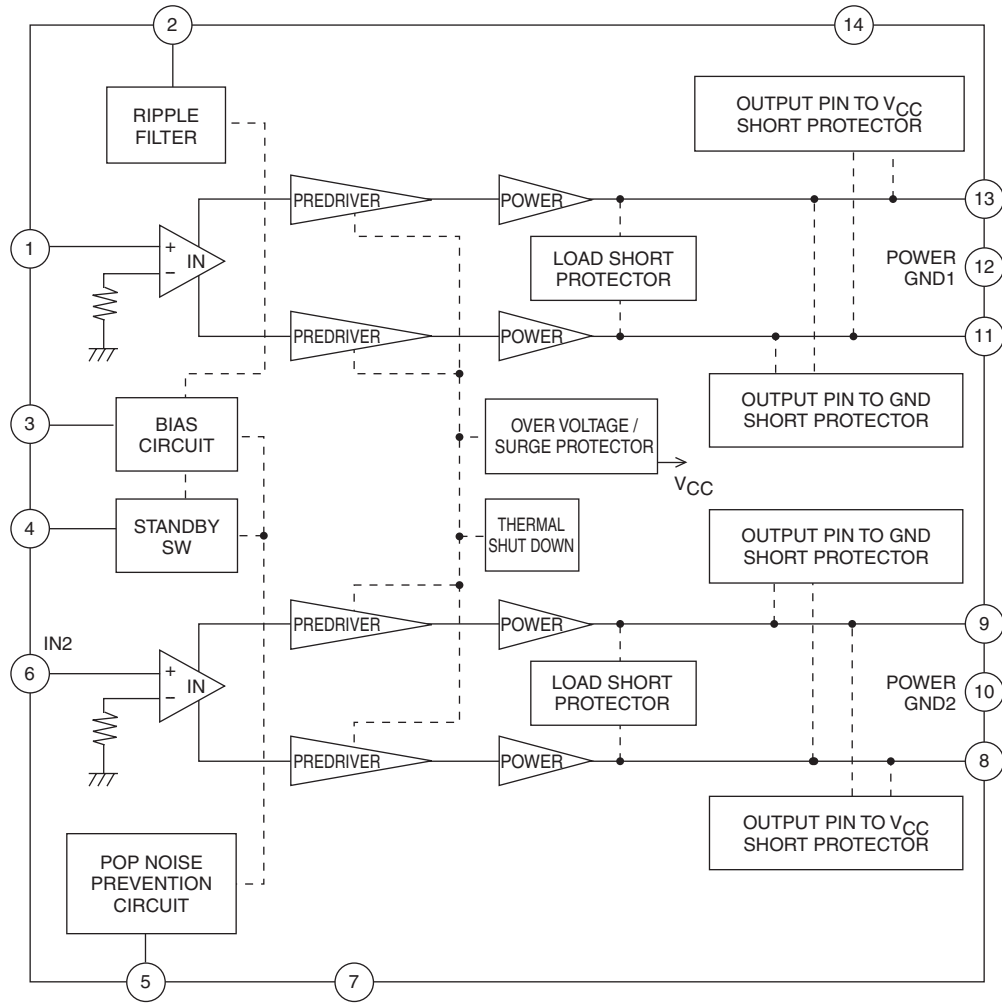

A
B
C
D
E
F

8. PANEL FACILITIES

MAIN UNIT

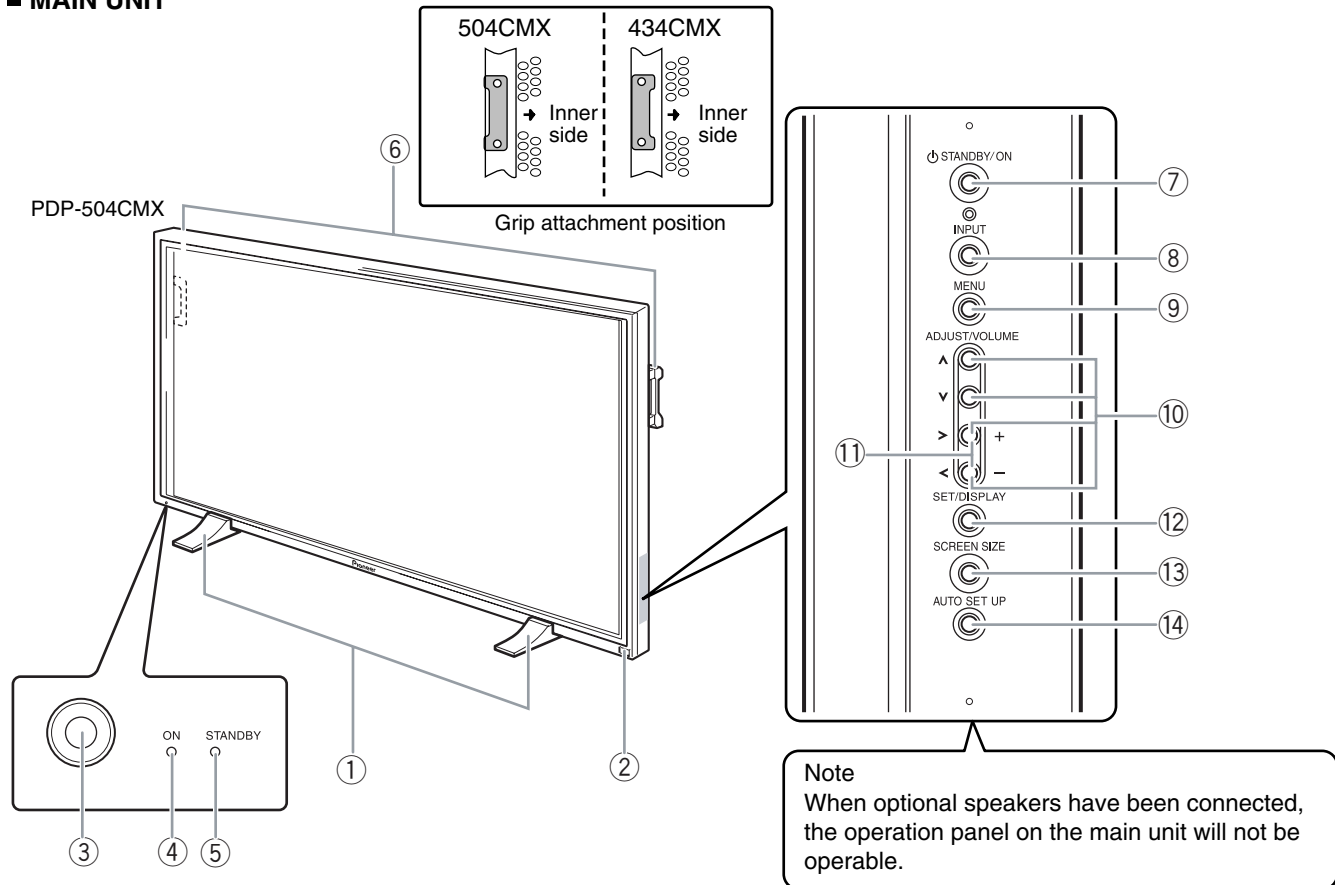

Main unit

- ① **Display stand**
- ② **Remote control sensor**
Point the remote control toward the remote sensor to operate the unit .
- ③ **Ambient light sensor**
This sensor measures the level of light inside the viewing room; it is enabled when the [ENERGY SAVE] option is set to [AUTO] .
- ④ **ON indicator**
Lights green when the plasma display is operating. When flashing, the indicator is used to indicate error messages. The indicator flashes green once every two seconds when the [POWER MANAGEMENT] function is operating.
- ⑤ **STANDBY indicator**
Lights red when the unit is in standby mode. When flashing, the indicator is used to indicate error messages.
- ⑥ **Handles**
The plasma displays PDP-50MXE1/PDP-50MXE1-S and PDP-43MXE1/PDP-43MXE1-S utilize differing methods of handle attachment, but the handles themselves are used in the same way.
Operation panel on the main unit
- ⑦ **STANDBY/ON button**
Press to put the display in operation or standby mode.

Operation panel on the main unit

- ⑧ **INPUT button**
Press to select the input.
- ⑨ **MENU button**
Press to open and close the on-screen menu.
- ⑩ **ADJUST (▲/▼/▶/◀) buttons**
Use these buttons to move the onscreen cursor between selection options, and to perform adjustments. Instructions for use are given with each command option onscreen.
- ⑪ **VOLUME (+/-) buttons**
When not indicated for use in onscreen menu items, these buttons are used for adjusting the sound volume.
- ⑫ **SET/DISPLAY button**
Use to confirm onscreen menu selections, and to change settings. When not indicated by onscreen menus, used to display the current set status.
- ⑬ **SCREEN SIZE button**
Press to select the screen size.
- ⑭ **AUTO SET UP button**
When using computer signal input, automatically sets the [POSITION], [CLOCK] and [PHASE] to optimum values.

■ CONNECTION PANEL (PLASMA DISPLAY SECTION)

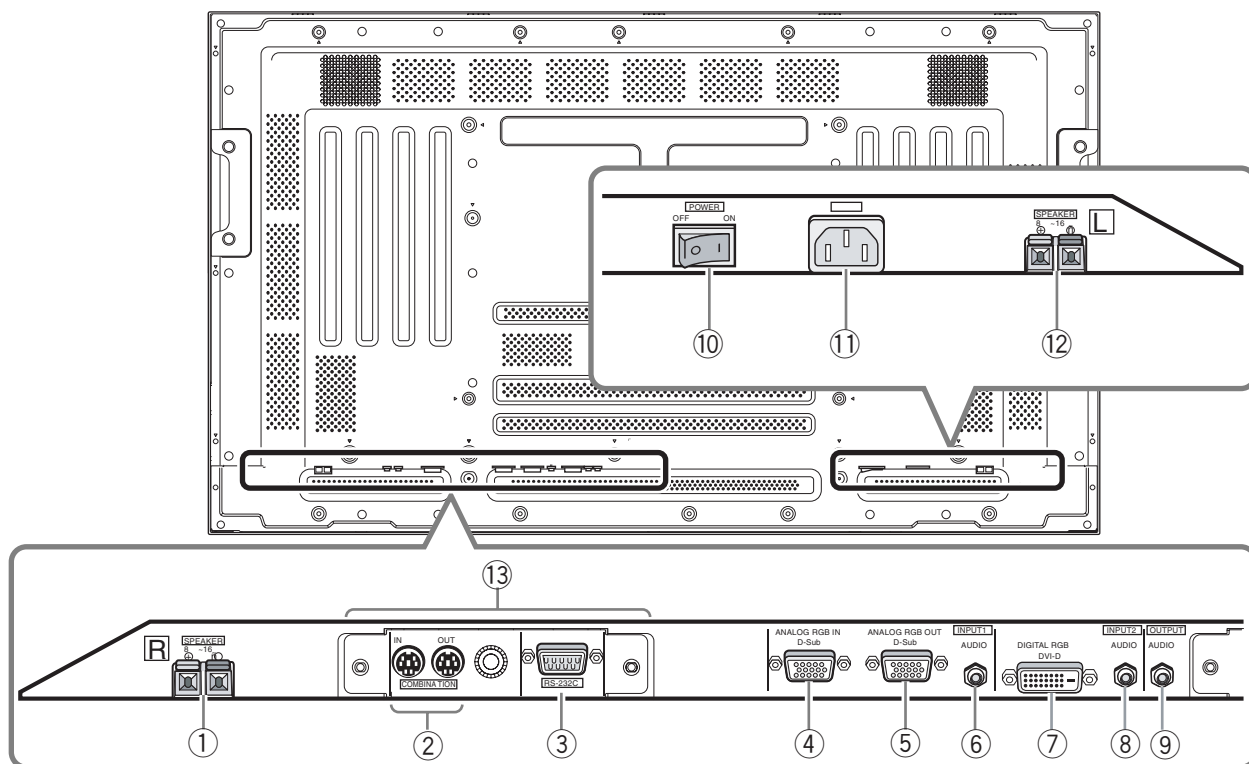

Plasma Display Section

The plasma display is provided with 2 video input connectors, 1 video output connector, audio input/output jacks and speaker terminals.

When this video card is installed on a plasma display, an additional three sets of video input connectors are provided (total five), together with one additional video output connector (total two).

- ① **SPEAKER (R) terminal**
For connection of an external right speaker.
Connect a speaker that has an impedance of 8 -16 Ω.
- ② **COMBINATION IN/OUT**
Never connect any component to these connectors without first consulting your Pioneer installation technician.
These connectors are used in the factory setup.
- ③ **RS-232C**
Never connect any component to this connector without first consulting your Pioneer installation technician.
This connector is used in the factory setup.
- ④ **ANALOG RGB IN (INPUT1) (mini D-sub 15 pin)**
For connection of a personal computer (PC) or similar component. Make sure that the connection made corresponds to the format of the signal output from the connected component.
- ⑤ **ANALOG RGB OUT (INPUT1) (mini D-sub 15 pin)**
Use the ANALOG RGB OUT (INPUT1) terminal to output the video signal to an external monitor or other component.
Note: The video signal will not be output from the ANALOG RGB OUT (INPUT1) terminal when the main power of this unit is off or in standby mode.
- ⑥ **AUDIO (INPUT1) (Stereo mini jack)**
Use to obtain sound when INPUT1 is selected.
Connect the audio output jack of components connected to INPUT1 to this unit.
- ⑦ **DIGITAL RGB (INPUT2) (DVI-D jack)**
Use to connect a computer.
Note: This unit does not support the display of copyguard-protected video signals.
- ⑧ **AUDIO (INPUT2) (Stereo mini jack)**
Use to obtain sound when INPUT2 is selected.
Connect the audio output jack of components connected to INPUT2 to this unit.
- ⑨ **AUDIO (OUTPUT) (Stereo mini jack)**
Use to output the audio of the selected source component connected to this unit to an AV amplifier or similar component.
- ⑩ **MAIN POWER switch**
Use to switch the main power of the unit on and off.
- ⑪ **AC IN**
Use to connect a power cord to an AC outlet.
- ⑫ **SPEAKER (L) terminal**
For connection of an external left speaker. Connect a speaker that has an impedance of 8 -16 Ω.

■ CONNECTION PANEL (VIDEO CARD SECTION: PDA-5003, PDA-5004)

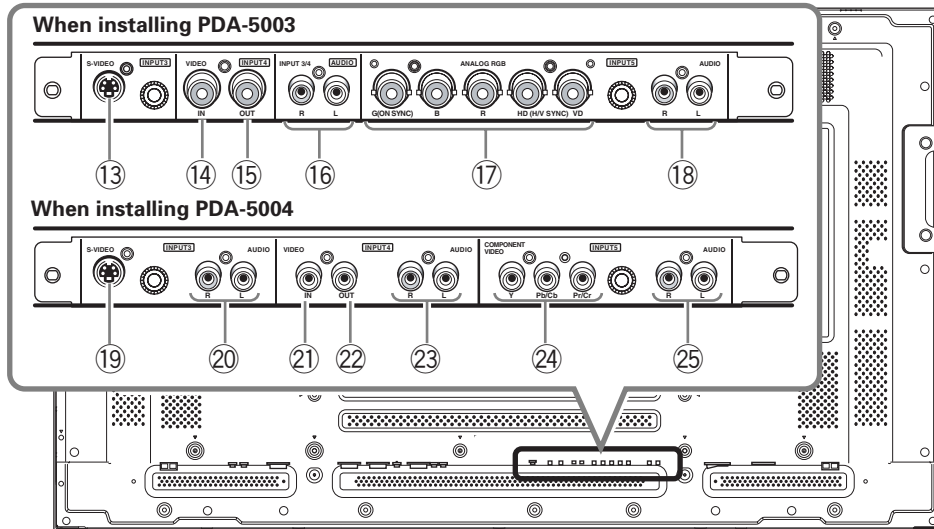

Video Card <PDA-5003> Section

The video card is provided with 3 video input connectors, 1 video output connector, and 2 audio input connectors. Consult the pages noted in parentheses () for details regarding connections to the various jacks and connectors.

⑬ S-VIDEO (INPUT3) (S-video jack)

For connection of components that have an S-video output jack such as a video deck, video camera, laser disc player, or DVD recorder).

⑭ VIDEO IN (INPUT4) (BNC jack)

For connection of components that have a composite video output jack such as a video deck, video camera, laser disc player, or DVD recorder.

⑮ VIDEO OUT (INPUT4) (BNC jack)

Use the VIDEO OUT (INPUT4) jack to output the video signal to an external monitor or other component.
Note: The video signal will not be output from the VIDEO OUT (INPUT4) jack when the main power of this display is off or in standby mode.

⑯ AUDIO R/L (INPUT3/4) (RCA Pin jacks)

Use to obtain sound when INPUT3 or INPUT4 is selected. Connect these jacks to the audio output connectors of components connected to the video card's INPUT3 or INPUT4.

Note: The left audio channel (L) jack is not compatible with monaural input sources.

⑰ ANALOG RGB (INPUT5) (BNC jacks)

For connecting components equipped with RGB outputs jacks, such as a personal computer or external RGB decoder; or components equipped with component output jacks, such as a DVD recorder.

Make sure that the connection made corresponds to the format of the signal output from the connected component.

⑱ AUDIO R/L (INPUT5) (RCA Pin jacks)

Use to obtain sound when INPUT5 is selected. Connect these jacks to the audio output connectors of components connected to the video card's INPUT5.

Note: The left audio channel (L) jack is not compatible with monaural input sources.

Video Card <PDA-5004> Section

The video card is provided with 3 video input connectors, 1 video output connector, and 3 audio input connectors. Consult the pages noted in parentheses () for details regarding connections to the various jacks and connectors.

⑲ S-VIDEO (INPUT3) (S-video jack)

For connection of components that have an S-video output jack such as a video deck, video camera, laser disc player, or DVD recorder.

⑳ AUDIO R/L (INPUT3) (RCA Pin jacks)

Use to obtain sound when INPUT3 is selected. Connect these jacks to the audio output connectors of components connected to the video card's INPUT3.

Note: The left audio channel (L) jack is not compatible with monaural input sources.

㉑ VIDEO IN (INPUT4) (RCA Pin jack)

For connection of components that have a composite video output jack such as a video deck, video camera, laser disc player, or DVD recorder.

㉒ VIDEO OUT (INPUT4) (RCA Pin jack)

Use the VIDEO OUT (INPUT4) jack to output the video signal to an external monitor or other component.

Note: The video signal will not be output from the VIDEO OUT (INPUT4) jack when the main power of this display is off or in standby mode.

㉓ AUDIO R/L (INPUT4) (RCA Pin jacks)

Use to obtain sound when INPUT4 is selected. Connect these jacks to the audio output connectors of components connected to the video card's INPUT4.

Note: The left audio channel (L) jack is not compatible with monaural input sources.

㉔ COMPONENT VIDEO (INPUT5) (RCA Pin jacks)

For connection of components that have component video output jacks such as a DVD recorder.

㉕ AUDIO R/L (INPUT5) (RCA Pin jacks)

Use to obtain sound when INPUT5 is selected. Connect these jacks to the audio output connectors of components connected to the video card's INPUT5.

Note: The left audio channel (L) jack is not compatible with monaural input sources.

■ REMOTE CONTROL UNIT

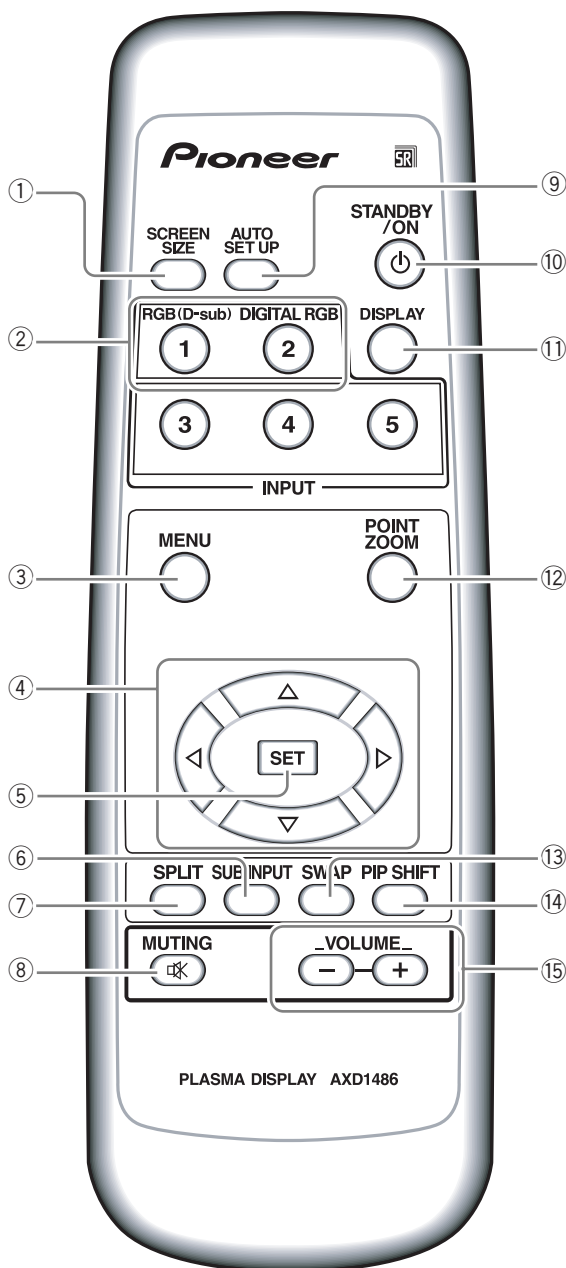

- ① **SCREEN SIZE button**
Press to select the screen size.
- ② **INPUT buttons**
Press to select the input .
- ③ **MENU button**
Press to open and close the on-screen menu.
- ④ **ADJUST (▲ / ▼ / ► / ◄) buttons**
Use to navigate menu screens and to adjust various settings on the unit.
Usage of cursor buttons within operations is clearly indicated at the bottom the on-screen menu display.
- ⑤ **SET button**
Press to adjust or enter various settings on the unit.
- ⑥ **SUB INPUT button**
During multi-screen display, use this button to change inputs to subscreens.
- ⑦ **SPLIT button**
Press to switch to multi-screen display.
- ⑧ **MUTING button**
Press to mute the volume.
- ⑨ **AUTO SET UP button**
When using computer signal input, automatically sets the [POSITION], [CLOCK] and [PHASE] to optimum values.
- ⑩ **STANDBY/ON button**
Press to put the unit in operation or standby mode.
- ⑪ **DISPLAY button**
Press to view the unit's current input and setup mode.
- ⑫ **POINT ZOOM button**
Use to select and enlarge one part of the screen.
SWAP button During multi-screen display, use this button to switch between main screen and subscreen.
- ⑬ **INPUT SWAP button**
During multi-screen display, use this button to switch between main screen and subscreen.
- ⑭ **PIP SHIFT button**
When using PinP mode with multi-screen display, use this button to move the position of subscreen.
- ⑮ **VOLUME (+/-) buttons**
Use to adjust the volume.

■ INSTALLATION OF THE UNIT

Installation using the supplied display stand

Be sure to fix the supplied stand to the installation surface. Use commercially available M8 bolts that are 25 mm longer than the thickness of the installation surface.

1. Fix the supplied stand to the installation surface at each of the 4 prepared holes using commercially available M8 bolts .

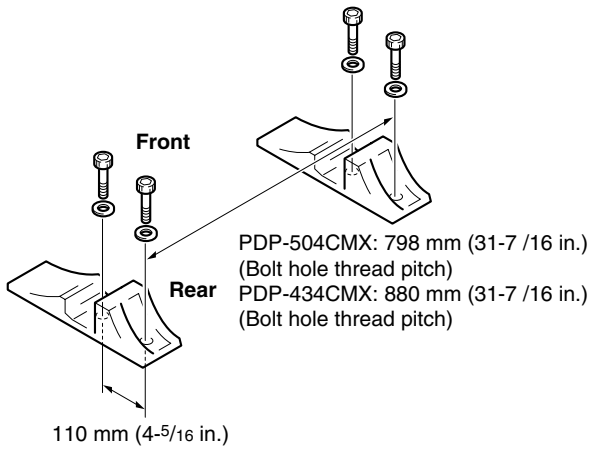

3. Fix this unit using the supplied washer and bolt.

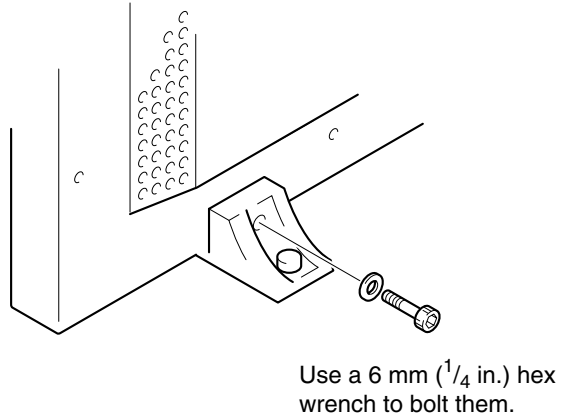

2. Set this unit in the stand.

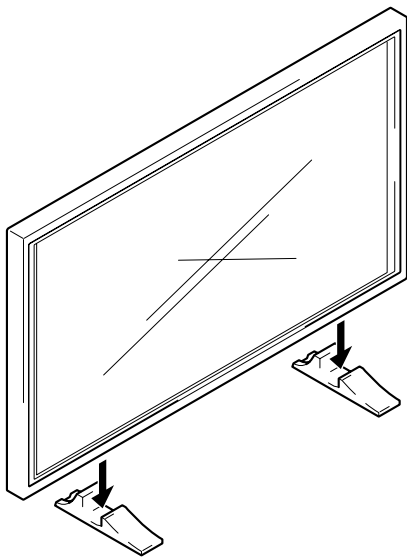

⚠ CAUTION

This display unit weighs at least 30 kg (67 lbs) and has little front-to-back depth, making it very unstable when stood on edge. As a result, two or more persons should cooperate when unpacking, moving, or installing the display.

Installation using the optional PIONEER stand or installation bracket

- Please be sure to request installation or mounting of this unit or the installation bracket by an installation specialist or the dealer where purchased.
- When installing, be sure to use the bolts provided with the stand or installation bracket.
- For details concerning installation, please refer to the instruction manual provided with the stand or installation bracket.

Installation using accessories other than the PIONEER stand or installation bracket (sold separately)

- When possible, please install using parts and accessories manufactured by PIONEER. PIONEER will not be held responsible for accident or damage caused by the use of parts and accessories manufactured by other companies.
- For custom installation, please consult the dealer where the unit was purchased, or a qualified installer.

Wall-mount installation of the unit

This unit has been designed with bolt holes for wall-mount installation, etc.. The installation holes that can be used are shown in the diagram below.

- Be sure to attach in 4 or more locations above and below, left and right of the center line.
- Use bolts that are long enough to be inserted 1/2 inch (12 mm) to 11/16 inch (18 mm) into the main unit from the attaching surface for both a holes and b holes. Refer to the side view diagram below.
- As this unit is constructed with glass, be sure to install it on a flat, unwarped surface.

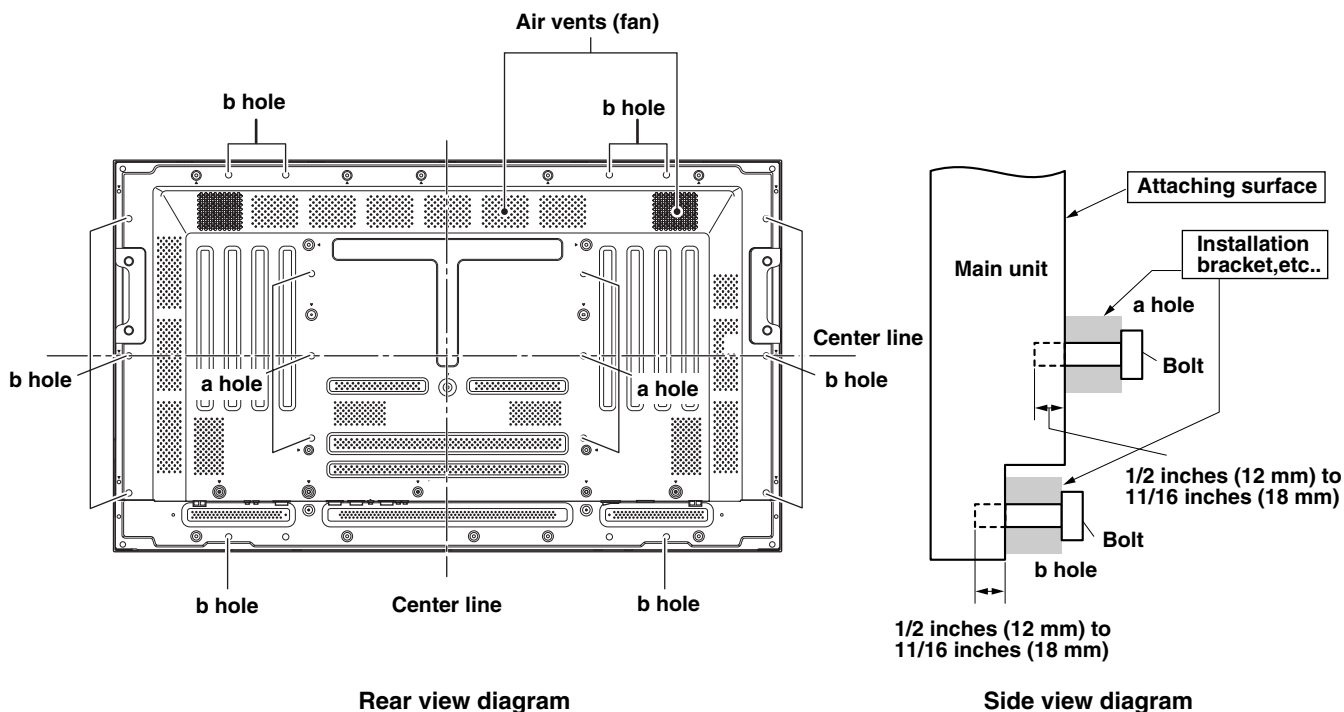

Rear view diagram

Side view diagram

⚠ CAUTION

To avoid malfunction, overheating of this unit, and possible fire hazard, make sure that the vents on the main unit are not blocked when installing. Also, as hot air is expelled from the air vents, be careful of deterioration and dirt build up on rear surface wall, etc..

⚠ CAUTION

Please be sure to use an M8 (Pitch = 1.25 mm) bolt. (Only this size bolt can be used.)

⚠ CAUTION

Because this unit weighs about 88 lbs 3 oz (about 40 kg) and the lack of depth makes it fairly unstable, please use 2 people or more when packing, carrying or installing.

⚠ CAUTION

This unit incorporates a thin design. To ensure safety if vibrated or shaken, please be sure to take measures to prevent the unit from tipping over.